

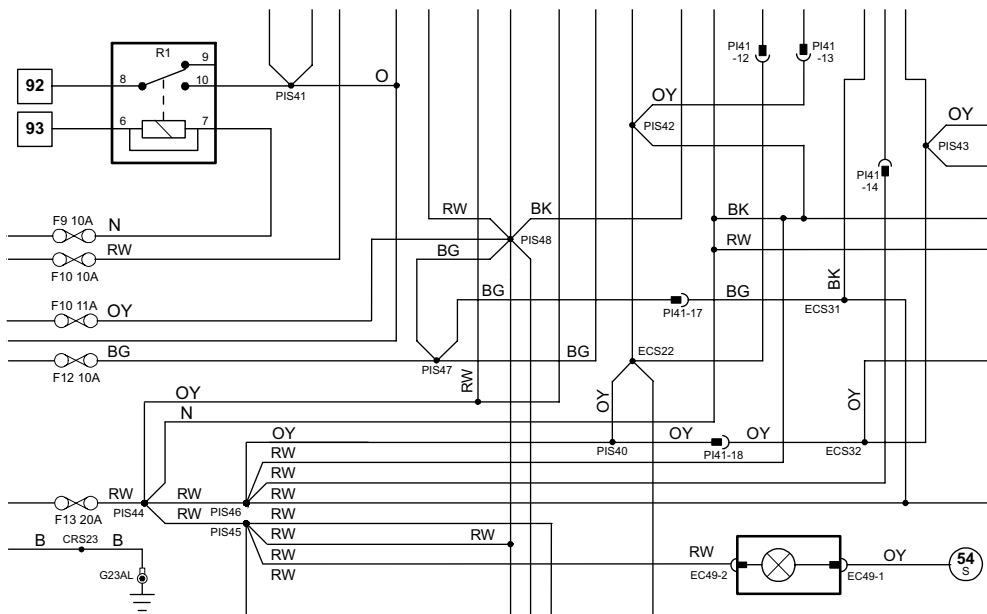

Electrical Guide



S-TYPE Sedan

Gasoline and Diesel

2006 Model Year, VIN: N52048 onwards



BY APPOINTMENT TO
HER MAJESTY QUEEN ELIZABETH II
MANUFACTURERS OF DAIMLER AND JAGUAR CARS
JAGUAR CARS LIMITED COVENTRY



BY APPOINTMENT TO
HER MAJESTY QUEEN ELIZABETH
THE QUEEN MOTHER
MANUFACTURERS OF DAIMLER AND JAGUAR CARS
JAGUAR CARS LIMITED COVENTRY



BY APPOINTMENT TO
HIS ROYAL HIGHNESS THE PRINCE OF WALES
MANUFACTURERS OF DAIMLER AND JAGUAR CARS
JAGUAR CARS LIMITED COVENTRY

Electrical Guide

S-TYPE Sedan

Gasoline and Diesel

2006 Model Year, VIN: N52048 onwards

Published by Technical Communications, **Jaguar Cars Limited**

Publication Part Number JJM 10 38 16 701, April 2006

While every effort is made to ensure accuracy, design changes to the vehicle may be made in the period between the completion of this publication and the introduction of vehicles.

All rights reserved. No part of this publication may be reproduced, stored in a retrieval system or transmitted, in any form: electronic, mechanical, including photocopying, recording or other means without prior written permission from the Service Division of Jaguar Cars Limited.

Table of Contents: Figures	2
Abbreviations and Acronyms	4
Introduction	6
User Instructions	7
Symbols and Codes	9
Network Configuration	12
Fusebox Location	13
Relay and Fuse Location	14
Harness In-Line Connectors	15
Control Module Location	17
Ground Point Location	19
Control Module Pin Identification	20
Diesel Engine Sensors and Actuators	30
Electrical Guide Figures and Data	follows after page 31 (pages are numbered by Figure number)
Component Index	follows after Figures and Data

FIGURES

Fig.	Description	Variant
01 Power Distribution		
Fig. 01.1	Main Power Distribution	All Vehicles
Fig. 01.2	Battery Power Distribution: Part 1	All Vehicles
Fig. 01.3	Battery Power Distribution: Part 2	All Vehicles
Fig. 01.4	Ignition Switched Power Distribution: I (Accessory)	All Vehicles
Fig. 01.5	Ignition Switched Power Distribution: II (Run)	All Vehicles
Fig. 01.6	Switched System Power Distribution	All Vehicles
Fig. 01.7	Engine Management System Switched Power Distribution: Gasoline	Gasoline Vehicles
Fig. 01.8	Engine Management System Switched Power Distribution: Diesel 2.7V6	Diesel 2.7V6
02 Battery; Starter; Generator		
Fig. 02.1	Battery; Starter; Generator: V6	V6 Vehicles
Fig. 02.2	Battery; Starter; Generator: V8	V8 Vehicles
Fig. 02.3	Battery; Starter; Generator: Diesel 2.7V6	Diesel 2.7V6
03 Engine Management		
Fig. 03.1	Engine Management: V6 – Part 1	V6 Vehicles
Fig. 03.2	Engine Management: V6 – Part 2	V6 Vehicles
Fig. 03.3	Engine Management: V8 N/A – Part 1	V8 N/A Vehicles
Fig. 03.4	Engine Management: V8 N/A – Part 2	V8 N/A Vehicles
Fig. 03.5	Engine Management: V8 SC – Part 1	V8 SC Vehicles
Fig. 03.6	Engine Management: V8 SC – Part 2	V8 SC Vehicles
Fig. 03.7	Engine Management: Diesel 2.7V6 – Part 1	Diesel 2.7V6
Fig. 03.8	Engine Management: Diesel 2.7V6 – Part 2	Diesel 2.7V6
Fig. 03.9	Engine Management: Secondary Air Injection - NAS	NAS Gasoline Vehicles
04 Transmission		
Fig. 04.1	Transmission (Automatic)	Automatic Vehicles
Fig. 04.2	Transmission (Manual)	Manual Vehicles
05 Chassis		
Fig. 05.1	Dynamic Stability Control	All Vehicles
Fig. 05.2	Electronic Parking Brake; Variable Assist Power Steering	All Vehicles
Fig. 05.3	Adaptive Speed Control	Adaptive Speed Control Vehicles
Fig. 05.4	Suspension Adaptive Damping	Adaptive Damping Vehicles
06 Climate Control		
Fig. 06.1	Climate Control System; Windshield Heaters	All Vehicles
07 Instrumentation		
Fig. 07.1	Instrument Cluster; Audible Warnings	All Vehicles
08 Exterior Lighting		
Fig. 08.1	Exterior Lighting: Front	Non HID Headlamp Vehicles
Fig. 08.2	Exterior Lighting: Front – HID	HID Headlamp Vehicles
Fig. 08.3	Exterior Lighting: Rear	All Vehicles
Fig. 08.4	Exterior Lighting: Rear – Trailer Towing	Trailer Towing Vehicles
Fig. 08.5	Headlamp Leveling	Headlamp Leveling Vehicles
09 Interior Lighting		
Fig. 09.1	Interior Lighting	All Vehicles
Fig. 09.2	Dimmer-Controlled Lighting	All Vehicles

FIGURES

Fig.	Description	Variant
10	Steering Column; Pedals; Mirrors; Heaters	
Fig. 10.1	Steering Column Adjust; Pedal Adjust	All Vehicles
Fig. 10.2	Door Mirrors: Movement and Heaters; Heated Rear Window	All Vehicles
Fig. 10.3	Electrochromic Rear View Mirror; Fold-Back Mirrors	All Vehicles; Fold-Back Mirror Vehicles
11	Seat Systems	
Fig. 11.1	Driver Seat: 10-way Movement with Memory	10-Way Driver Seat Memory Vehicles
Fig. 11.2	Driver Seat: 16-way Movement with Memory	16-Way Driver Seat Memory Vehicles
Fig. 11.3	Driver Seat: Non Memory	Non Memory Driver Seat Vehicles
Fig. 11.4	Passenger Seat: 4 to 10-way Movement.	4 / 6 / 8 / 10-Way Passenger Seat Vehicles
Fig. 11.5	Passenger Seat: 12-way Movement	12-Way Passenger Seat Vehicles
Fig. 11.6	Seat Heaters	Heated Seat Vehicles
12	Central Locking; Security	
Fig. 12.1	Central Locking: Double Locking.	Double Locking Vehicles
Fig. 12.2	Central Locking: Non Double Locking	Non Double Locking Vehicles
Fig. 12.3	Security System.	All Vehicles
13	Wash / Wipe	
Fig. 13.1	Wash / Wipe System	All Vehicles
14	Powered Windows; Sliding Roof	
Fig. 14.1	Powered Windows; Sliding Roof	All Vehicles
15	In-Car Entertainment	
Fig. 15.1	In-Car Entertainment: Standard.	Standard ICE Vehicles
Fig. 15.2	In-Car Entertainment: Premium.	Premium ICE Vehicles
16	Telematics	
Fig. 16.1	Telephone System.	Telephone only Vehicles
Fig. 16.2	Telephone System with Voice	Telephone with Voice Vehicles
Fig. 16.3	Voice Control System	Voice Only Vehicles
Fig. 16.4	Navigation System: (Except Japan)	Navigation Vehicles (except Japan)
Fig. 16.5	Navigation System: Japan.	Japan Navigation Vehicles
17	Occupant Protection	
Fig. 17.1	Advanced Restraint System: Part 1.	All Vehicles
Fig. 17.2	Advanced Restraint System: Part 2.	All Vehicles
18	Driver Assist	
Fig. 18.1	Parking Aid System.	Parking Aid Vehicles
19	Ancillaries	
Fig. 19.1	Ancillaries	All Vehicles
20	Vehicle Multiplex Systems	
Fig. 20.1	Controller Area Network	All Vehicles
Fig. 20.2	Standard Corporate Protocol Network; Serial Data Link	All Vehicles
Fig. 20.3	D2B Network: Part 1	All Vehicles
Fig. 20.4	D2B Network: Part 2	All Vehicles
Fig. 20.5	D2B Network: Part 3	All Vehicles
Fig. 20.6	D2B Network: Part 4	All Vehicles

The following abbreviations and acronyms are used throughout this Electrical Guide:

A/C	Air Conditioning
A/CCM	Air Conditioning Control Module
ACT SENSOR	Air Charge Temperature Sensor
APP SENSOR	Accelerator Pedal Position Sensor
APP1	Accelerator Pedal Position Sensor Element 1
APP2	Accelerator Pedal Position Sensor Element 2
ASC	Adaptive Speed Control
AUTO	Automatic Transmission
B+	Battery Voltage
BANK 1	RH Cylinder Bank
BANK 2	LH Cylinder Bank
CAN	Controller Area Network
CKP SENSOR	Crankshaft Position Sensor
CM	Control Module
CMP SENSOR / 1	Camshaft Position Sensor / RH Bank
CMP SENSOR / 2	Camshaft Position Sensor / LH Bank
D2B	D2B Network
DDM	Driver Door Module
DPF	Diesel Particulate Filter
DSC	Dynamic Stability Control
DSM	Driver Seat Module
ECM	Engine Control Module
ECT SENSOR	Engine Coolant Temperature Sensor
EFT SENSOR	Engine Fuel Temperature Sensor
EGR	Exhaust Gas Recirculation
EGT SENSOR	Exhaust Gas Temperature Sensor
EOT SENSOR	Engine Oil Temperature Sensor
EVAP CANISTER CLOSE VALVE	Evaporative Emission Canister Close Valve
EVAP CANISTER PURGE VALVE	Evaporative Emission Canister Purge Valve
FEM	Front Electronic Module
FPDB	Front Power Distribution Box
FRP SENSOR	Fuel Rail Pressure Sensor
FTP SENSOR	Fuel Tank Pressure Sensor
GPS	Global Positioning System
HID	High Intensity Discharge
HO2 SENSOR 1 / 1	Heated Oxygen Sensor – RH Bank / Upstream
HO2 SENSOR 1 / 2	Heated Oxygen Sensor – RH Bank / Downstream
HO2 SENSOR 2 / 1	Heated Oxygen Sensor – LH Bank / Upstream
HO2 SENSOR 2 / 2	Heated Oxygen Sensor – LH Bank / Downstream
IAT SENSOR	Intake Air Temperature Sensor
IC	Instrument Cluster
ICE	In-Car Entertainment System
IMT VALVE / 1	Intake Manifold Tuning Valve / Top
IMT VALVE / 2	Intake Manifold Tuning Valve / Bottom
IP SENSOR	Injection Pressure Sensor
KS / 1	Knock Sensor / RH Bank
KS / 2	Knock Sensor / LH Bank
LH	Left-Hand
LHD	Left-Hand Drive
MAF SENSOR	Mass Air Flow Sensor
MAN	Manual Transmission
MAP SENSOR	Manifold Absolute Pressure Sensor
N/A	Normally Aspirated
NAS	North American Specification
NCM	Navigation Control Module
PAM	Parking Aid Module
PATS	Passive Anti-Theft System
PJB	Primary Junction Box
PWM	Pulse Width Modulated
RCM	Restraints Control Module
REM	Rear Electronic Module
RH	Right-Hand
RHD	Right-Hand Drive
ROW	Rest of World
RPDB	Rear Power Distribution Box
SAI	Secondary Air Injection
SC	Supercharged
SCLM	Steering Column Lock Module

SCM	Speed Control Module
SCP	Standard Corporate Protocol Network
TCM	Transmission Control Module
TP SENSOR	Throttle Position Sensor
TP1	Throttle Position Sensor Element 1
TP2	Throttle Position Sensor Element 2
TPMS	Tire Pressure Monitoring System
TURN	Turn Signal
TV	Television
V6	V6 Engine
V8	V8 Engine
VAM	Voice Activation Module
VICS	Vehicle Information Control System
VVT VALVE / 1	Variable Valve Timing Valve / Bank 1
VVT VALVE / 2	Variable Valve Timing Valve / Bank 2
+ve	Positive
-ve	Negative

Electrical Guide Format

This Electrical Guide is made up of two major sections:

- the first section, at the front of the book, provides general information for and about the use of the book; model-specific information and illustrations to aid in the understanding of the electrical / electronic systems, as well as the location and identification of components.
- the second section includes the Figures, which are the basis of the book. Each Figure is identified by a Figure Number (e.g. Fig. 01.1) and Title. The page adjacent to the Figure contains data information specific to that Figure.

NOTE: Data pages are not available for inclusion in Provisional versions of the Electrical Guide.

It is recommended that the user read through the front section of the book to develop a familiarity with the layout of the book and with the system of symbols and abbreviations used. The Table of Contents should help to guide the user.

Vehicle Identification Numbers (VIN)

VIN ranges are presented throughout the book in the following manner:

› VIN 123456 indicates 'up to VIN 123456'; VIN 123456 › indicates 'from VIN 123456 on'.

Electrical System Architecture

Power Supplies

The electrical system is a supply-side switched system. The ignition switch directly carries much of the ignition switched power supply load.

Power supply is provided via three methods:

- Direct battery power supply;
- Ignition switched power supply;
- Switched system power supply.

The 'Switched System Power Supply' circuit is controlled via the FEM (Front Electronic Module) and the REM (Rear Electronic Module). Refer to Fig. 01.6 for circuit activation details.

Fuse Boxes

The electrical harness incorporates two hard-wired power distribution fuse boxes:

- the Front Power Distribution Fuse Box, located in the engine compartment;
- the Rear Power Distribution Fuse Box, located in the trunk.

A serviceable Primary Junction Fuse Box is located in the front right-hand foot well. All fuses and relays (except the trailer towing accessory kit) are located in the two fuse boxes.

Vehicle Networks

Three different networks are employed:

- CAN (Controller Area Network) for high-speed power train communications;
- SCP (Standard Corporate Protocol) network for slower speed body systems communications;
- D2B (Optical) Network for very high-speed 'real-time' audio data transfer.

NOTE: The D2B Network is a fiber optic network with a gateway to the remaining vehicle networks via the Audio Unit. Technician access to the three networks and the Serial Data Link is via the Data Link Connector.

Ground Studs

Circuit ground connections are made at body studs located throughout the vehicle. There are no separate power and logic grounding systems; however, there are a certain number of components that use unique ground points.

Figure and Data Page Layout

Figure Pages

Each Figure represents a specific electrical system of the vehicle. The Figures are arranged numerically by system (**01 – Power Distribution, 02 – Battery; Starter; Generator**, etc.) with variations in the system identified by a numeral following a decimal point (**01.1, 01.2**, etc.). Refer to the **Table of Contents: Figures** for a complete list of the Figures.

The Figures **01 – Power Distribution** detail the distribution of power to each of the systems. Numbered reference symbols refer the user to a specific Figure and from a specific Figure back to the Power Distribution Figures. This method eliminates the need to include detailed Power Distribution information on each of the Figures. The reference symbols are defined on page 9.

Each Figure appears on a right-hand page with a corresponding Data page to the left. The Figure and Data pages are folding pages. The user must fold out both pages in order to access all the information provided.

Data Pages

The Data page includes information to assist the user in identifying and locating components, connectors and grounds. This information is supplemented by the illustrations in this front section of the book.

Most circuits that incorporate a control module include pinout information. The characteristics listed are approximately those that can be expected at the control module connector pins with all circuit connections made and all components connected and fitted. This information is provided to assist the user in understanding circuit operation and should be used **FOR REFERENCE ONLY**.

CONTROL MODULE PIN OUT INFORMATION

FIGURE NUMBER

COMPONENT, CONNECTOR AND GROUND INFORMATION

Fig. 2.1

Engine Control Module		
Pin	Description and Characteristic	
I	PG16	IGNITION ON/ OFF
I	PG17	AUTOMATIC PARK NEUTRAL SIGNAL - WHEN ACTIVATED
I	PG18	IGNITION RELAY DRIVE - NEUTRAL SIGNAL - WHEN ACTIVATED
I	PG19	IGNITION RELAY DRIVE - NEUTRAL SIGNAL - WHEN ACTIVATED
O	PG20	STARTER RELAY DRIVE TO ACTIVATE LOW SPEEDS CIRCUIT TO GROUND
I	PG21	FUSE TRIP DRIVE TO FUSE PLAYS INDICATE FUSE IS IN NORMAL POSITIVE CARRY OVER RANGE - FS - 57A
I	PG22	GENERATOR FIELD ACTION SIGNAL, VARIABLE VOLTAGE BY GENERATOR OPERATING CONDITION
I	PG23	GENERATOR FIELD CHARGE WARNING
I	PG24	IGNITION

Instrument Cluster		
Pin	Description and Characteristic	
I	FC18-2	IGNITION SWITCHING BY GENERATOR ON
I	FC18-3	IGNITION SWITCHING BY GENERATOR OFF
I	FC18-4	SIGNAL GROUND
I	FC18-5	POWER GROUND
I	FC18-6	BATTERY POWER SUPPLY LOGIC - B+
I	FC18-7	FIELD GROUNDING
I	FC18-8	FIELD GROUNDING
I	FC18-9	PASSIVE ANTI-THEFT ENCODED COMMUNICATION
I	FC18-10	PASSIVE ANTI-THEFT ENCODED COMMUNICATION
I	FC18-11	IGNITION
I	FC18-12	IGNITION

Transmission Control Module		
Pin	Description and Characteristic	
B+	SS8-9	CANTON SWITCHED POWER SUPPLY B+
O	SS8-10	IGNITION SWITCHING BY GENERATOR ON
O	SS8-11	IGNITION SWITCHING BY GENERATOR OFF
O	SS8-12	POWER GROUND

NOTE: Refer to the Appendix at the rear of this book for Network Messages.

Component	Connector(s)	Connector Description	Location
BATTERY	—	2-WAY / BLACK	LUCKAGE COMPARTMENT
CLUTCH PEDAL SAFETY SWITCH	CA26	13-WAY / BLACK	TOP OF CLUTCH FROM BOTTOM SWITCH
ENGINE CONTROL MODULE	PH1	13-WAY / BLACK	FRONT BULKHEAD, PASSENGER SIDE
FRONT POWER DISTRIBUTION FUSE BOX	—	—	ENGINE COMPARTMENT, RH SIDE
GENERATOR (V6)	PH7	4-WAY / BLACK	ENGINE, RH SIDE, FRONT
IGNITION SWITCH	ST7	27-LETT	—
IGNITION SWITCH	FC18	7-WAY / BLACK	STEERING COLUMN COWLING
INSTRUMENT CLUSTER	FC14	25-WAY / GREY	INSTRUMENT PANEL
—	FC15	25-WAY / BLACK	—
—	FC16	25-WAY / BLACK	—
—	CA2	26-WAY / BLACK	STEERING COLUMN, IGNITION SWITCH
—	CA8	8-WAY / GREEN	RH K POST
—	CA8	8-WAY / BLACK	—
—	FC17	8-WAY / BLACK	—
—	PH7	16-WAY / BLACK	—
—	PH3	16-WAY / BLACK	—
STARTER MEGAFUSE	—	—	LUCKAGE COMPARTMENT
STARTER MOTOR	—	—	ENGINE BULK, RH SIDE
STARTER RELAY	—	—	FRONT POWER DISTRIBUTION FUSE BOX - F35
TRANSMISSION CONTROL MODULE	SS8	16-WAY / BLACK	TRANSMISSION CONTROL VALVE ASSEMBLY

HARNESS IN-LINE CONNECTORS		
Connector	Connector Description / Location	Location
PH1	16-WAY / BLACK / CAN HARNESS TO FRONT HARNESS	LH K POST
SS8	16-WAY / GREY / ENGINE HARNESS TO TRANSMISSION HARNESS	ADJACENT TO TRANSMISSION BELL HOUSING
PH1	43-WAY / BLACK / ENGINE HARNESS TO VEHICLE HARNESS	ENGINE COMPARTMENT, BULKHEAD, PASSENGER SIDE
PH2	8-WAY / BLACK / ENGINE HARNESS TO FRONT HARNESS	ENGINE COMPARTMENT, BULKHEAD, PASSENGER SIDE
ST4	2-WAY / GREY / FRONT HARNESS TO STARTER LINK	ENGINE COMPARTMENT, REARWARD OF RH WHEEL ARCH

GROUNDS	
Ground	Location
FC38	UNDER CENTER OF INSTRUMENT PANEL, ON TRANSMISSION TUNNEL
J61	LUCKAGE COMPARTMENT BATTERY GROUND
PH6 (LH)	ENGINE COMPARTMENT, BEHIND RH WHEEL ARCH LINER
PH6 (RH)	ENGINE COMPARTMENT, BEHIND LH WHEEL ARCH LINER
ST7	ENGINE COMPARTMENT, BEHIND LH WHEEL ARCH LINER

FOR CONTROL MODULE PIN-OUT INFORMATION, UNFOLD PAGE TO LEFT.

DATA PAGE

The following abbreviations are used to represent values for Control Module Pin-Out data

I Input PG Power Ground C CAN Network D Serial and Encoded Data
 O Output SS Sensor / Signal Supply V SCP Network V Voltage (DC)
 B+ Battery Voltage SG Sensor / Signal Ground DZ DZB Network PWM Pulse Width Modulated

CAUTION: The information on this data page is furnished to aid the user in understanding circuit operation. THIS INFORMATION SHOULD BE USED FOR REFERENCE ONLY.

NOTE: The values listed are approximately those that can be expected at the control module connector pins with all circuit connections made and all components connected and fitted.

Refer to the front of this book for detailed information and illustrations regarding the location and identification of harnesses, relays, fuses, grounds, control modules and control module pins.

DATE OF ISSUE: February 2004

DATE OF ISSUE

FIGURE MODEL RANGE AND YEAR

TITLE

FIGURE NUMBER

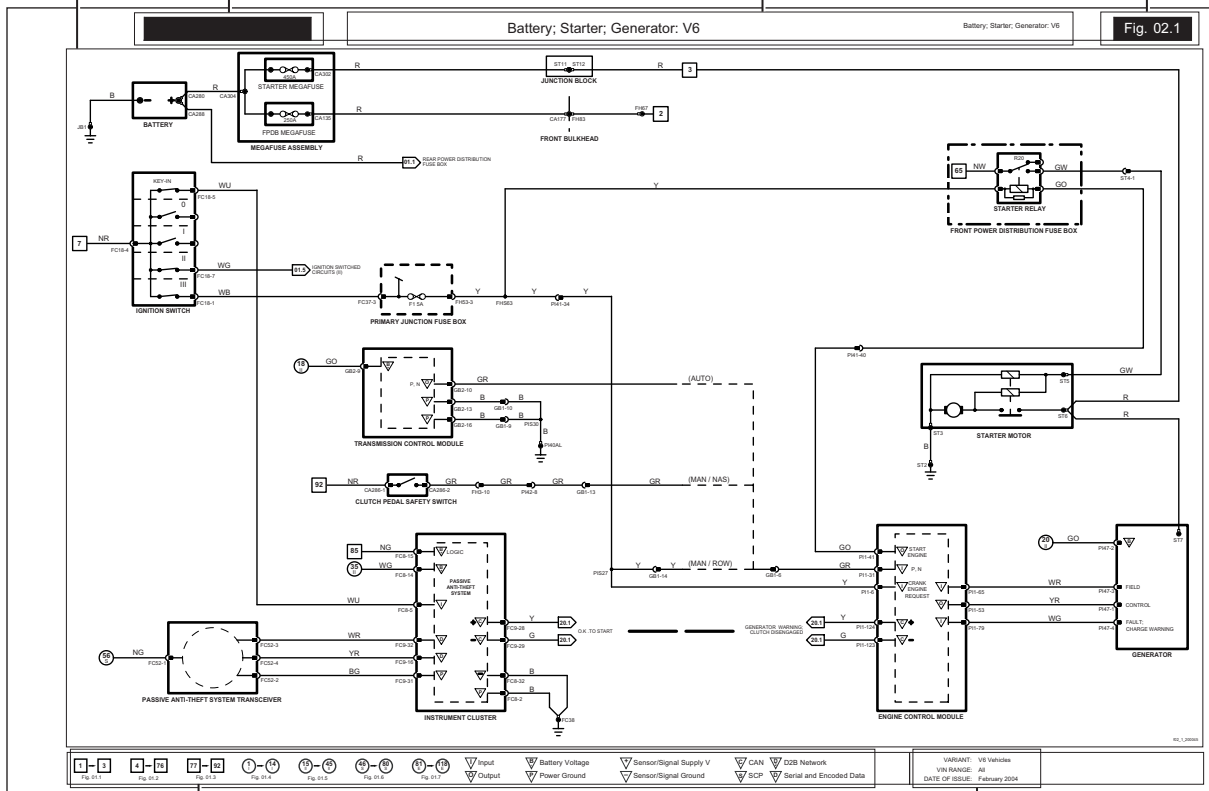

Fig. 02.1









FIGURE PAGE

KEY TO REFERENCE SYMBOLS











VARIANT, VIN RANGE AND DATE OF ISSUE

NOTE: In the examples on this page, an 'X' is used where a number would appear on an actual Figure.

Reference Symbols

	Battery power supply
	Ignition switched auxiliary power supply (key I, II)
	Ignition switched power supply (key II, III)
	Switched System Power Supply power supply
	Engine Management System power supply
	Figure number reference
	Controller Area Network
	Standard Corporate Protocol network
	D2B network











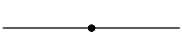
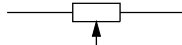
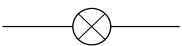
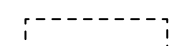
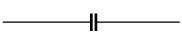
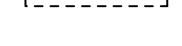
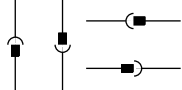

Control Module Pin Symbols

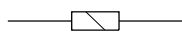
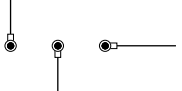
	Input		CAN network
	Output		SCP network
	Battery voltage		D2B network
	Power ground		Serial and encoded data
	Sensor / signal supply V *		
	Sensor / signal ground **		

* May also indicate Reference Voltage.

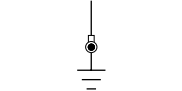
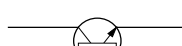
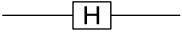
** May also indicate Reference Ground or Logic Ground.
Refer to Control Module Pin-out Information.

Wiring Symbols

Splice			Motor
Simplified splice			Potentiometer
Bulb			Power distribution box terminal
Capacitor			Pressure transducer
Connector			Resistor
Diode			Solenoid
Eyelet and stud			Suppression diode
Fuse			Suppression resistor
Ground			Thermistor
Hall effect sensor			Transistor
Light emitting diode (LED)			Wire continued
			Zener diode

Harness Codes

AC	Climate Control Link
AT	Alarm Link
BF	Front Bumper Harness
BR	Rear Bumper Harness
CA	Cabin Harness
CP	Intercooler Pump Link
CV	Canister Vent Link
DD	Driver Door Harness
DM	Driver Memory Seat Harness
DT	Driver Door Trim Link
FC	Fascia Harness
FH	Front Harness
FL	LH Front Headlamp Link
FP	Fuel Pump Harness
FR	RH Front Headlamp Link
GB	Transmission Harness
IL	Fuel Injector Link
PD	Passenger Door
PI	Engine Harness
PN	Passenger Seat Harness
PT	Passenger Door Trim Link
RA	D2B Network Harness
RF	Roof Harness
SL	Solar Sensor Link
SR	Sliding Roof Harness
SW	Subwoofer Link
TT	Trailer Tow Harness

Wiring Color Codes

N	Brown	O	Orange
B	Black	S	Slate
W	White	L	Light
K	Pink	U	Blue
G	Green	P	Purple
R	Red	BRD	Braid
Y	Yellow	BOF	Black fiber optic (D2B Network)

Code Numbering

When numbering connectors, grounds and splices, Jaguar Engineering uses a three-position format: CA001, CA002, etc. Because space is limited in this Electrical Guide the codes have, in most cases, been shortened. Thus CA001-001 becomes CA1-1, CA002-001 becomes CA2-1, etc.

Resistor Values

The omega symbol often used to represent resistance is not used in this publication.

- Whole-number resistor values below 1000 ohms are suffixed with 'R', for example: 820R.
- Whole-number resistor values above 1000 ohms are suffixed with 'K', for example: 820K.
- Fractional resistors values have 'R' or 'K' inserted at the position of the decimal point, for example: 8R2 represents 8.2 ohms, 1K0 represents 1K ohms.

Grounds

On figures where LHD and RHD circuits are combined and the ground designation differs from LHD to RHD, the RHD ground code is shown in parentheses. If the ground designation is the same for LHD and RHD, only one ground code is used, with no parentheses.

EXAMPLE:



Relays

All relays are located in the Front and Rear Power Distribution Boxes and the Primary Junction Fuse Box. Relays do not have a separate relay connector (base). All relays use the ISO pin numbering system (1, 2, 3, 4, 5). Each relay is identified by an 'R' number unique only to the fuse box in which it is located.

EXAMPLE:



Fuses

All fuses are located in the Front and Rear Power Distribution Boxes and the Primary Junction Fuse Box. Each fuse is identified by an 'F' number unique only to the fuse box in which it is located.

EXAMPLE:

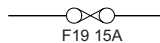

Networks

In most instances, networks are shown as a broken grey line to indicate that there is network communication between the depicted control modules. Refer to Fig. 20.1, Fig. 20.2, Fig. 20.3, Fig. 20.4 and Fig. 20.5 for circuit details.

EXAMPLE:

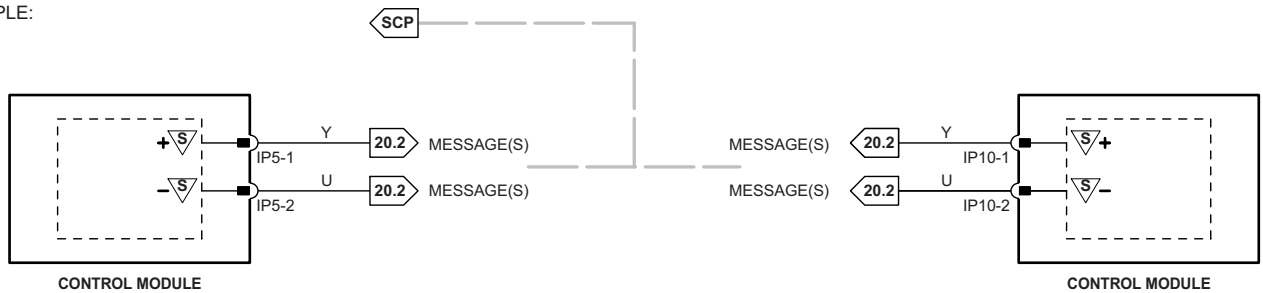

Component Depictions

EXAMPLE:

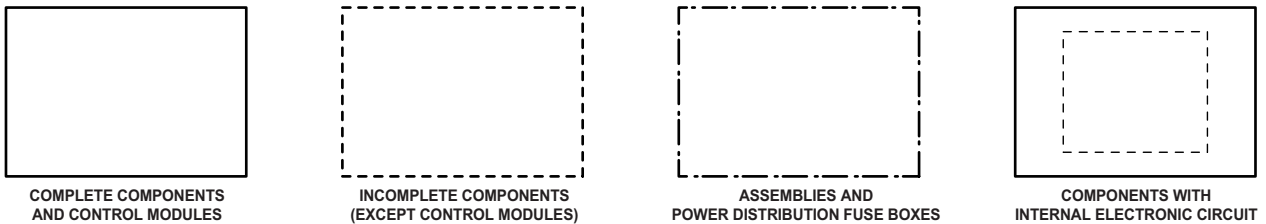

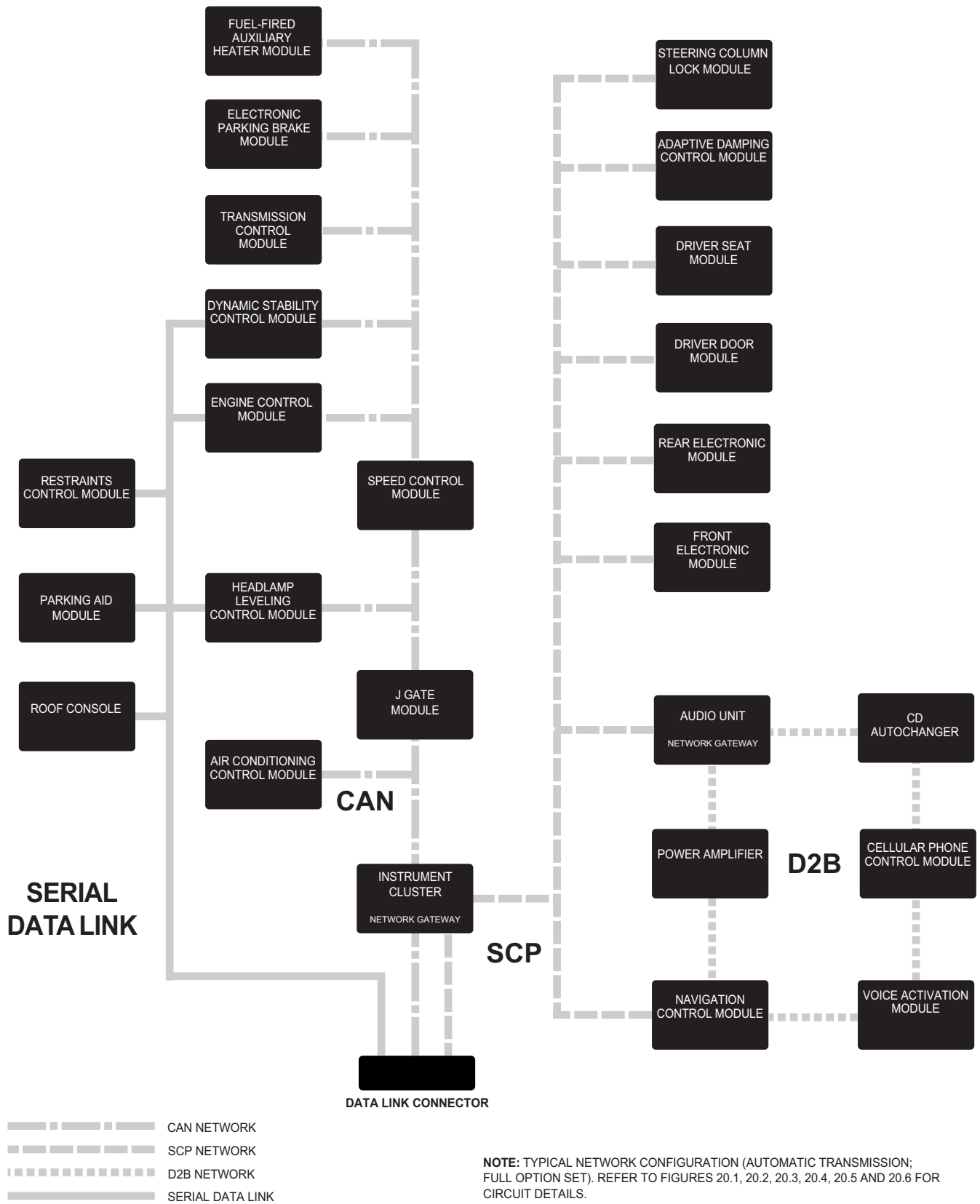

net_con_2006

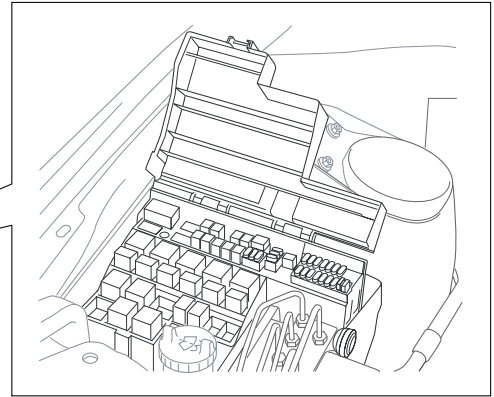
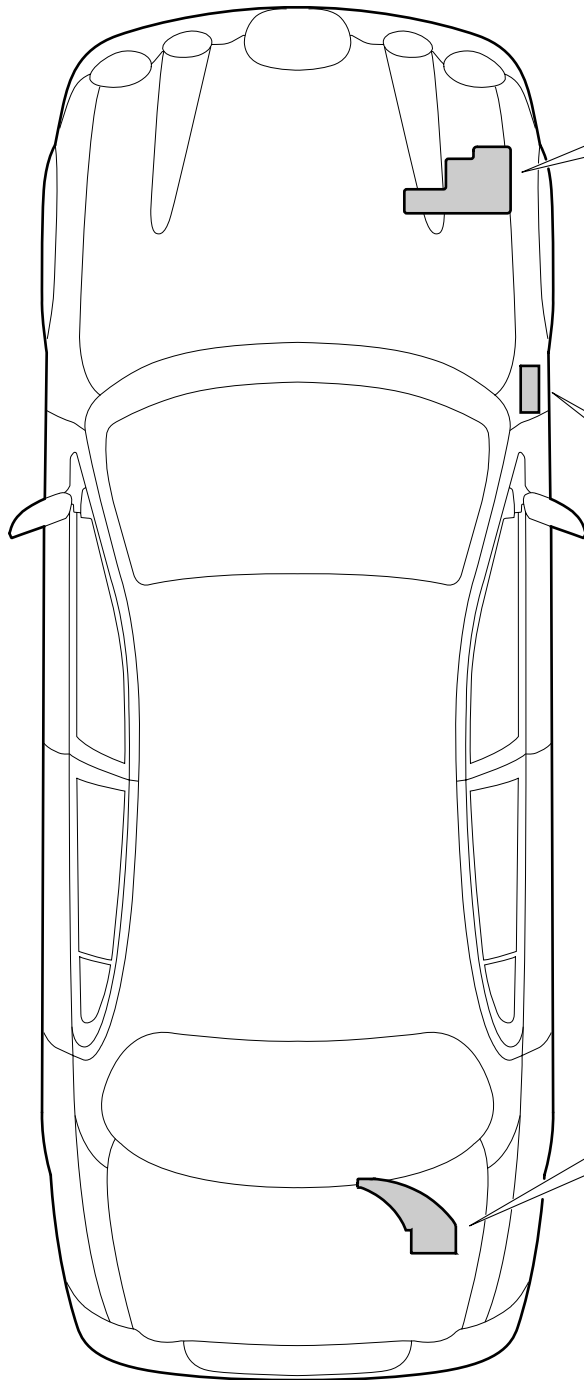

FRONT POWER DISTRIBUTION FUSE BOX

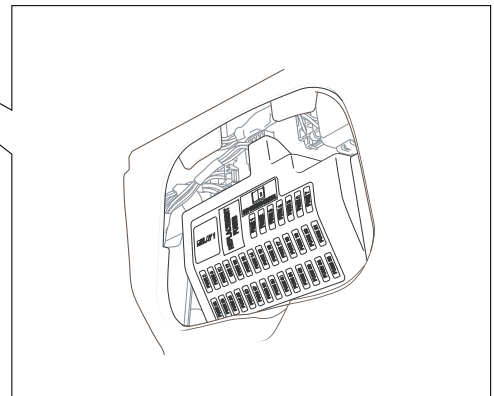

PRIMARY JUNCTION FUSE BOX

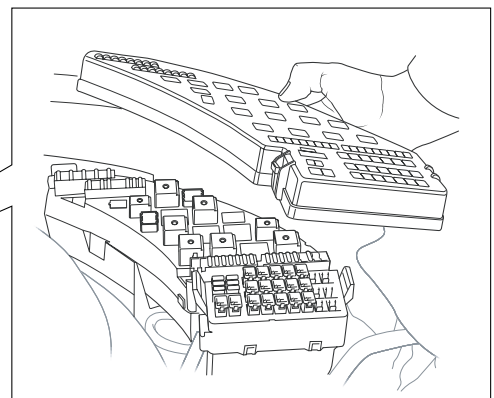

REAR POWER DISTRIBUTION FUSE BOX

FRONT POWER DISTRIBUTION FUSE BOX

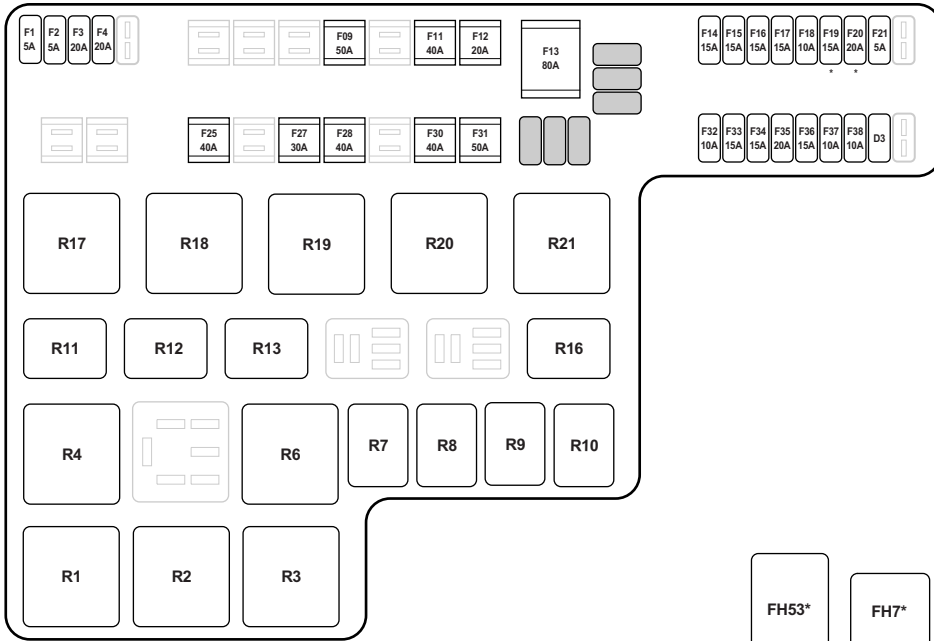

- R1 EMS CONTROL RELAY (DIESEL)
- R2 HEATED OXYGEN SENSOR RELAY
- R3 IGNITION COIL RELAY
- R4 EMS CONTROL RELAY (GASOLINE)
- R6 WIPER HIGH / LOW RELAY
- R7 AUXILIARY COOLANT PUMP RELAY
- R8 A/C COMPRESSOR CLUTCH RELAY
- R9 WATER PUMP RELAY (S/C)
- R10 LH HID RELAY
- R11 FRONT FOG LAMP RELAY
- R12 HORN RELAY
- R13 RH HID RELAY
- R16 WIPER PARK RELAY
- R17 LH WINDSHIELD HEATER RELAY
- R18 POWER WASH RELAY
- R19 SECONDARY AIR INJECTION RELAY
- R20 STARTER RELAY
- R21 RH WINDSHIELD HEATER RELAY

* NOTE: For Diesel vehicles, Fuse 19 is 10A and Fuse 20 is 30A

R1 CIGAR LIGHTER / POWER POINT RELAY

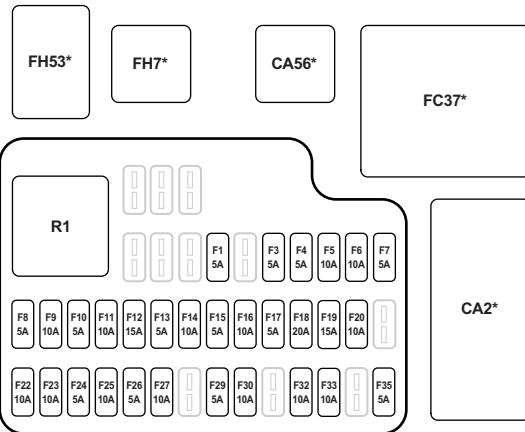

PRIMARY JUNCTION FUSE BOX

* PRIMARY JUNCTION FUSE BOX CONNECTORS

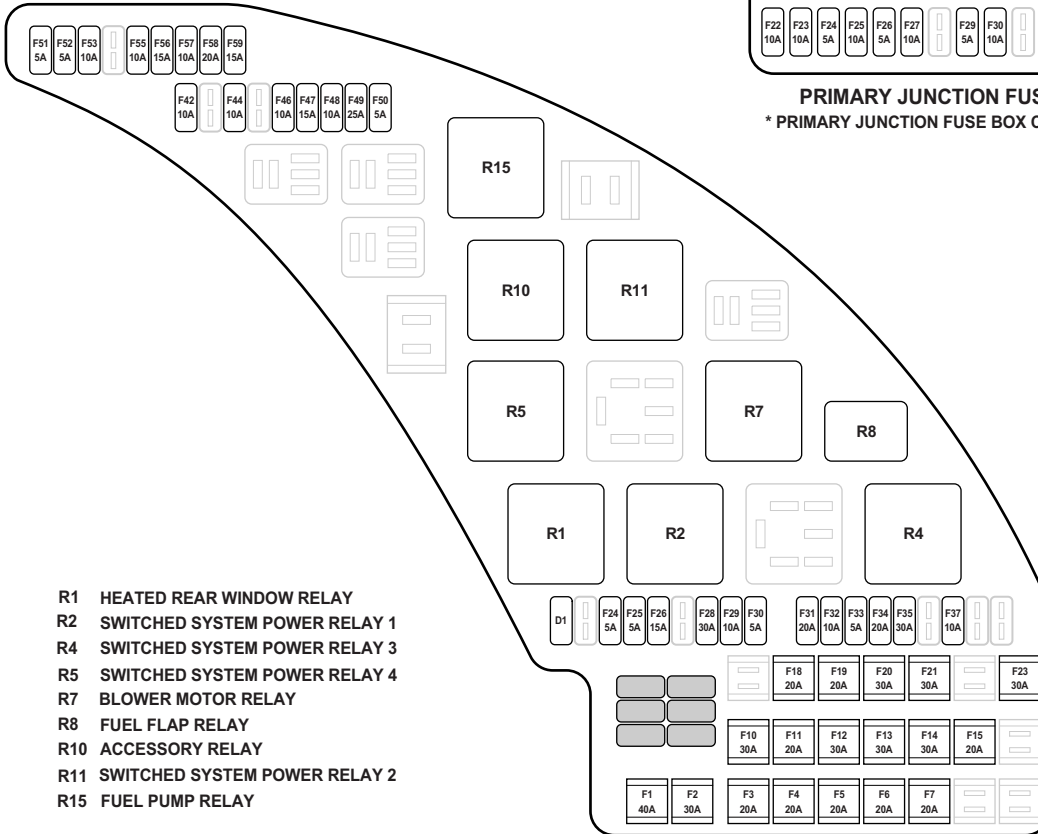

- R1 HEATED REAR WINDOW RELAY
- R2 SWITCHED SYSTEM POWER RELAY 1
- R4 SWITCHED SYSTEM POWER RELAY 3
- R5 SWITCHED SYSTEM POWER RELAY 4
- R7 BLOWER MOTOR RELAY
- R8 FUEL FLAP RELAY
- R10 ACCESSORY RELAY
- R11 SWITCHED SYSTEM POWER RELAY 2
- R15 FUEL PUMP RELAY

REAR POWER DISTRIBUTION FUSE BOX

relay_fuse_2006

LHD

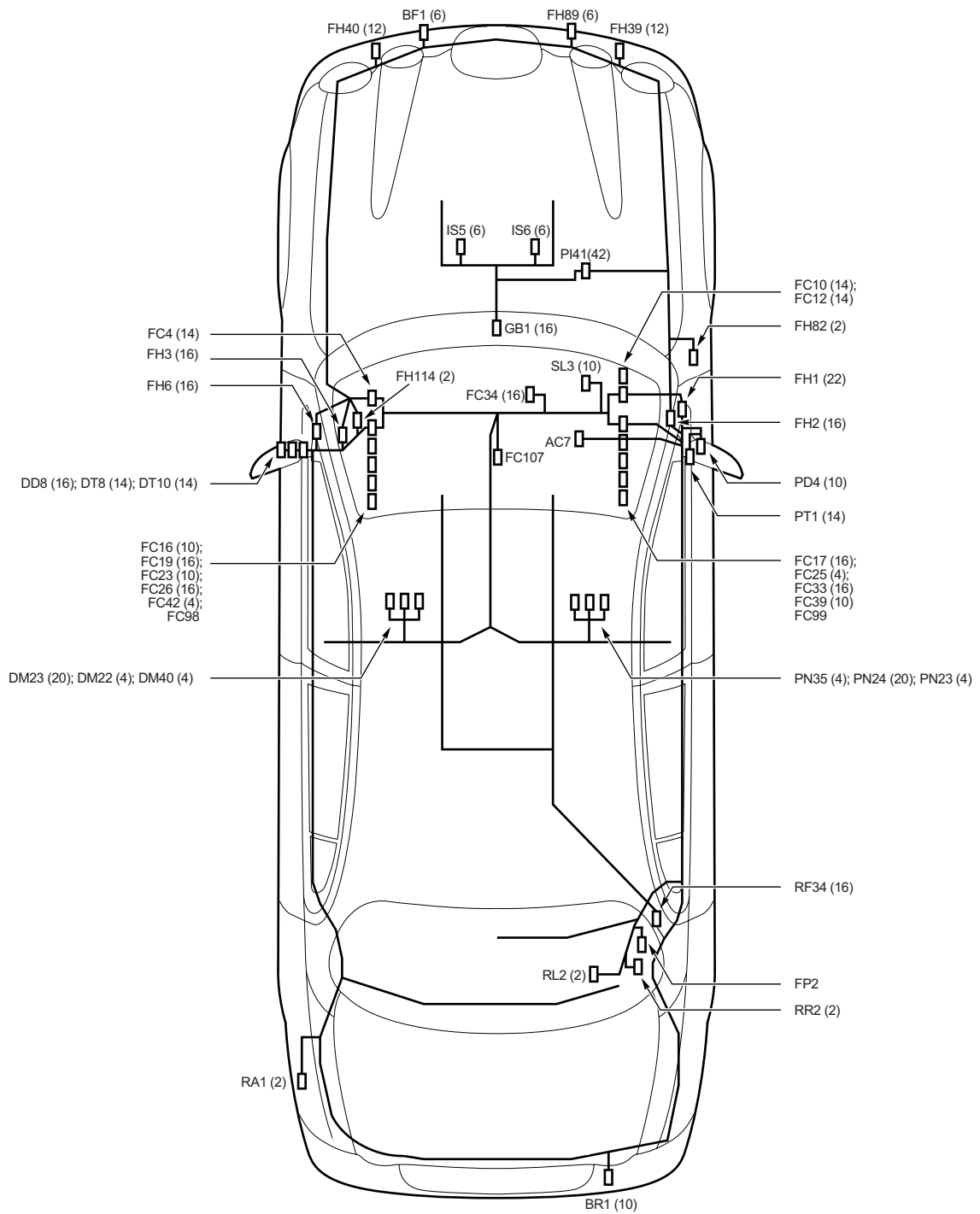

NOTE: WHERE THE INFORMATION IS AVAILABLE, THE NUMBER OF PINS CONTAINED IN A CONNECTOR IS SHOWN IN PARENTHESES.

RHD

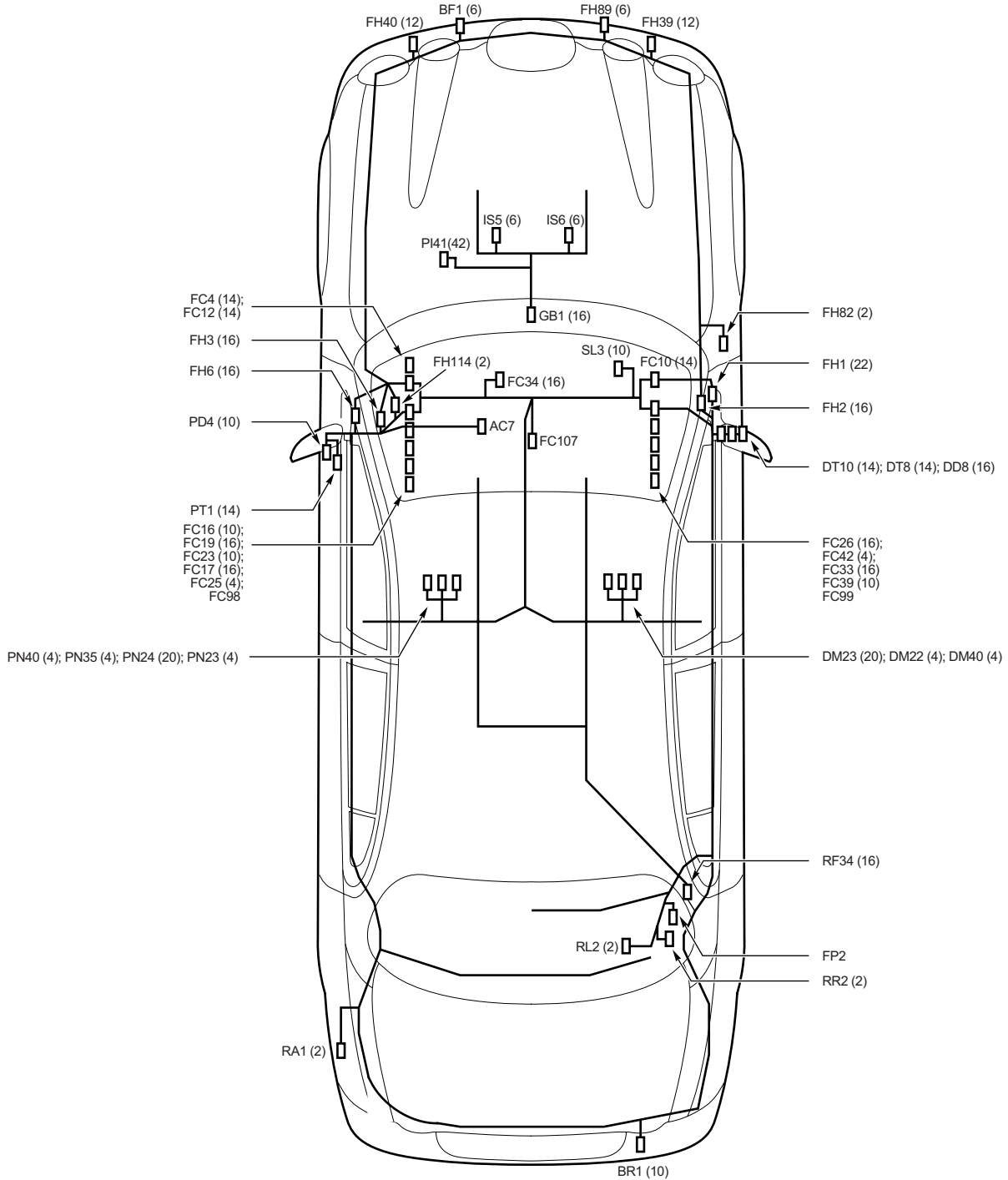

NOTE: WHERE THE INFORMATION IS AVAILABLE, THE NUMBER OF PINS CONTAINED IN A CONNECTOR IS SHOWN IN PARENTHESES.

harness_rhd_2006

LHD

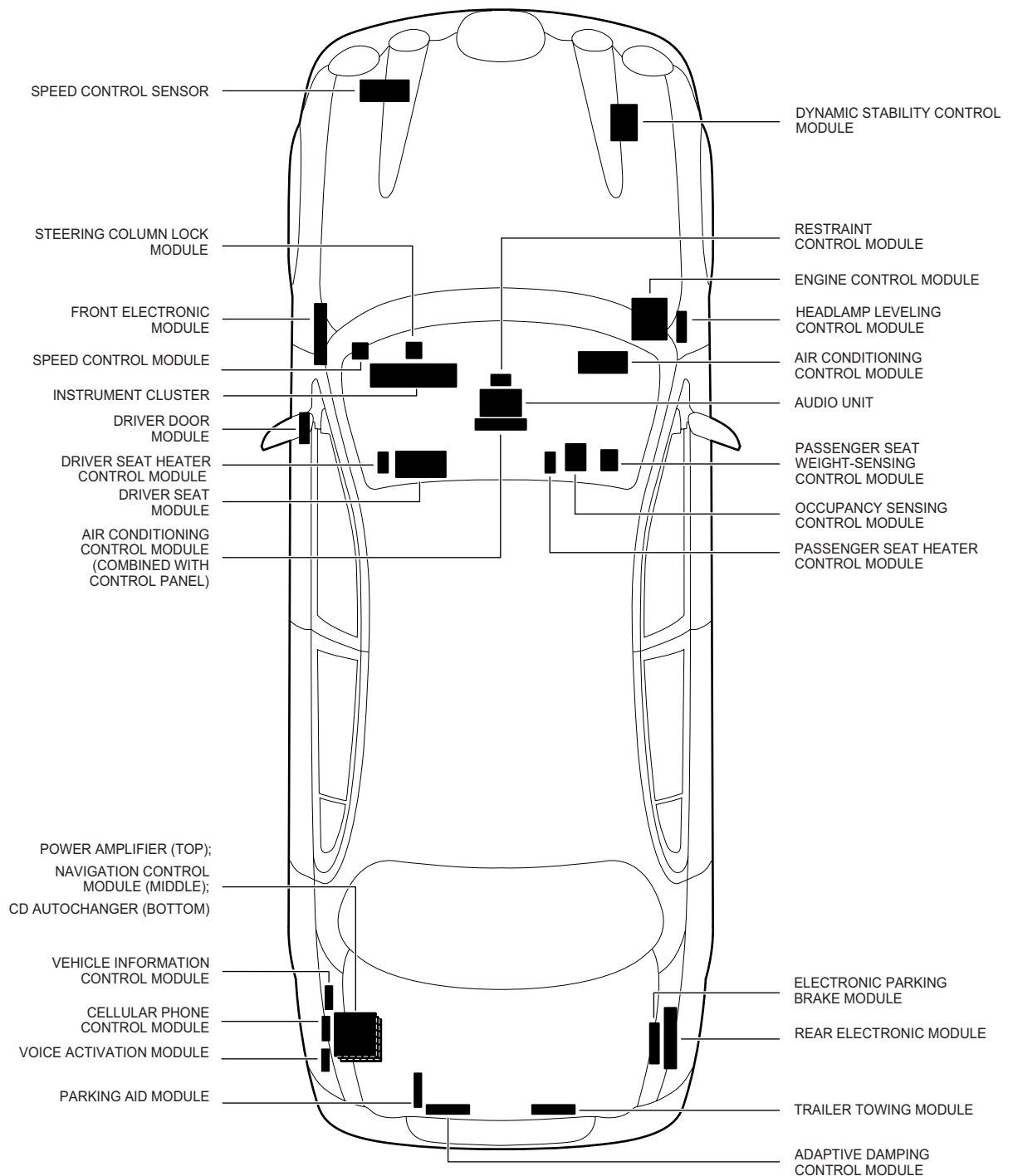

NOTE: THE TRANSMISSION CONTROL MODULE IS CONTAINED WITHIN THE TRANSMISSION.

RHD

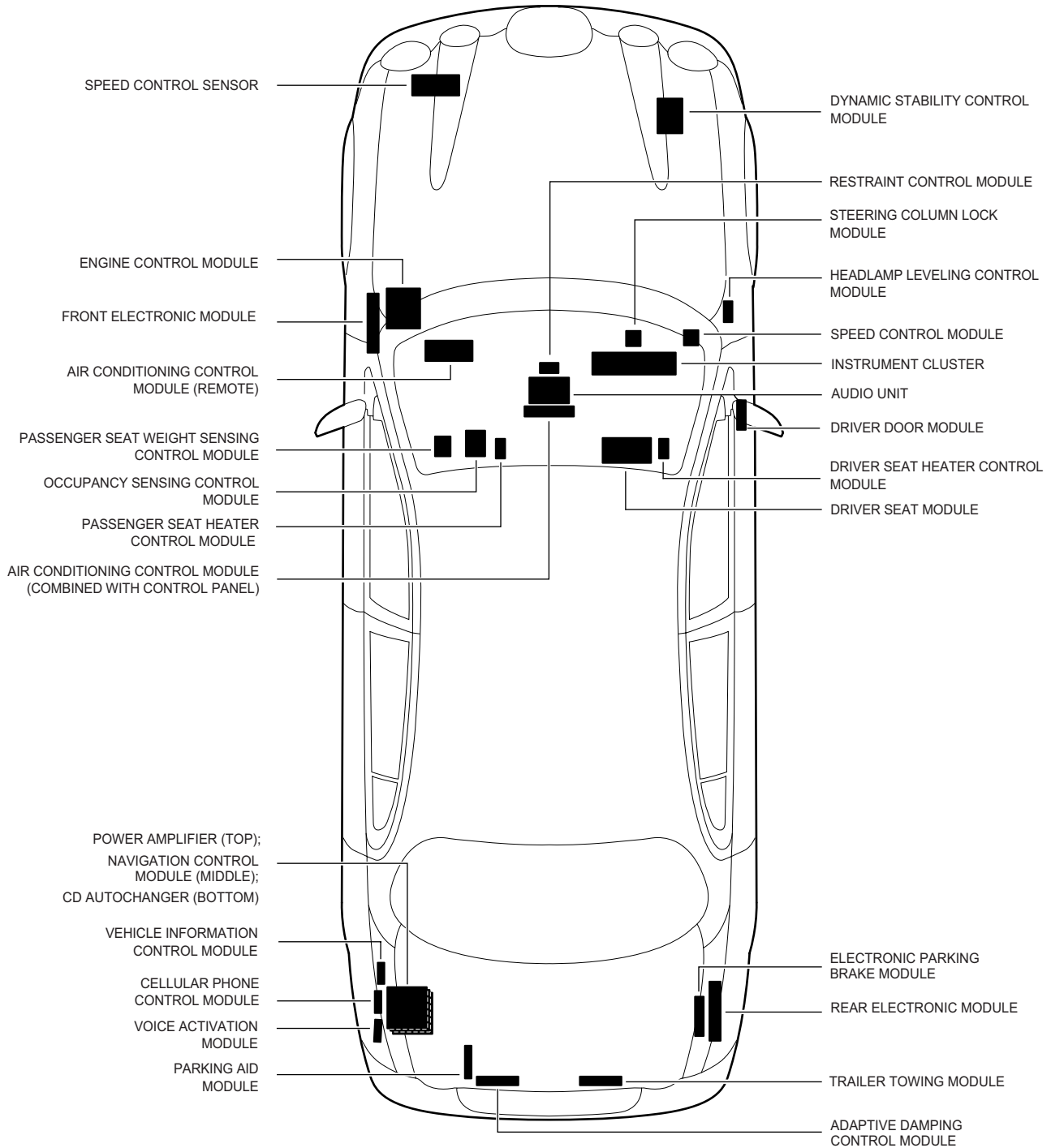

NOTE: THE TRANSMISSION CONTROL MODULE IS CONTAINED WITHIN THE TRANSMISSION.

rhd_cm_loc_20006

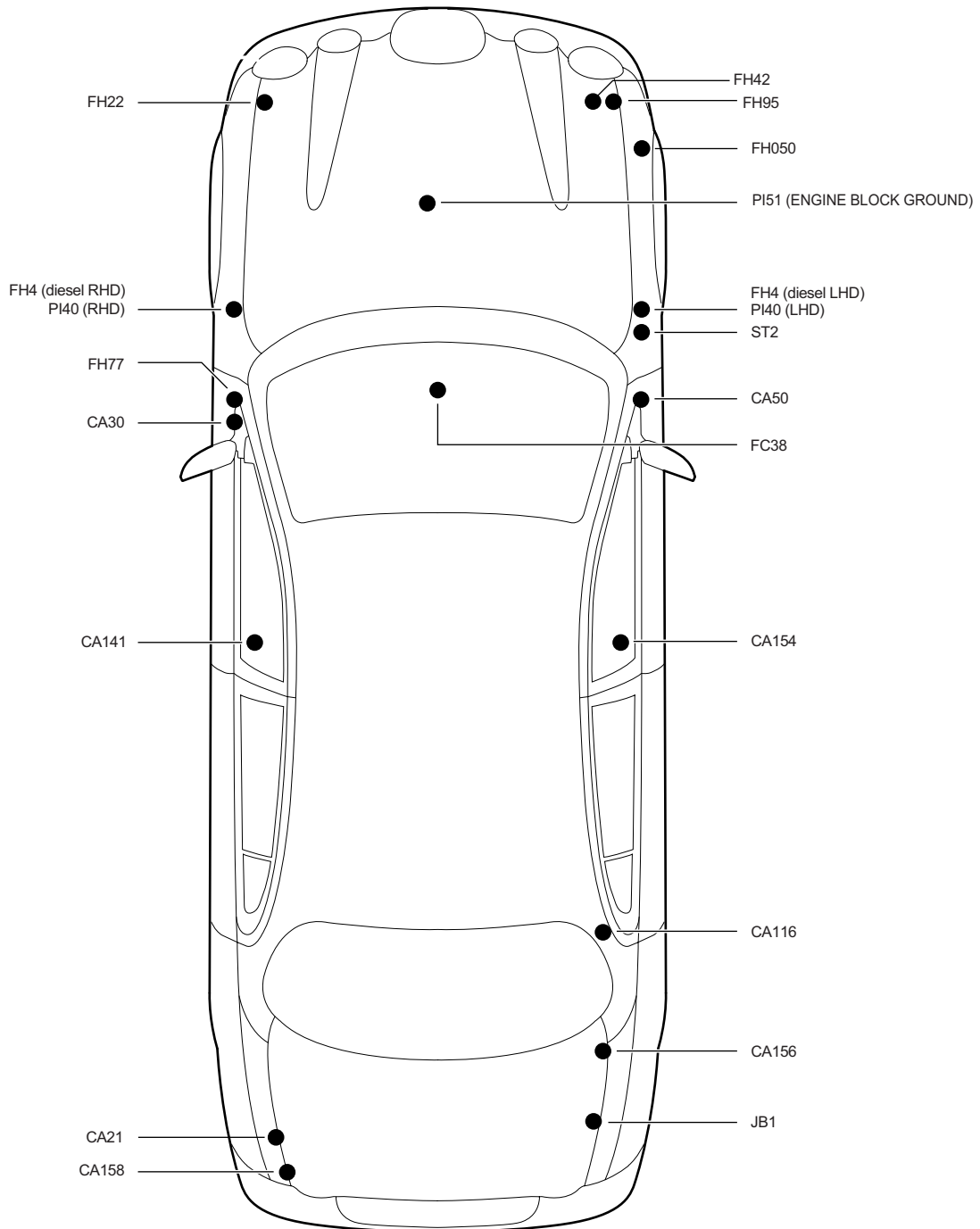

ENGINE CONTROL MODULE

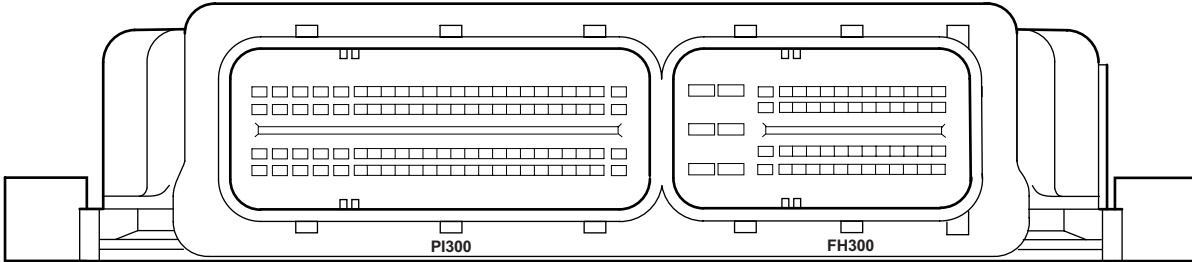

PI300 / BLACK

73	74	75	76	77	78	79	80	81	82	83	84	85	86	87	88	89	90	91	92	93	94	95	96
-	GW	OY	RG	RW	BG	BR	BK	BO	BG	U	OY	UY	Y	YU	UB	RB	OG	-	UY	-	-	-	YR
49	50	51	52	53	54	55	56	57	58	59	60	61	62	63	64	65	66	67	68	69	70	71	72
U	YU	YR	YG	YU	YR	GR	GR	YR	GW	Y	GW	GU	GB	-	YB	BW	U	Y	UY	BK	GW	U	Y

25	26	27	28	29	30	31	32	33	34	35	36	37	38	39	40	41	42	43	44	45	46	47	48
-	G	N	R	Y	O	-	-	N	Y	-	-	-	BW	BU	N	N	N	N	-	B	YR	OY	-
1	2	3	4	5	6	7	8	9	10	11	12	13	14	15	16	17	18	19	20	21	22	23	24
-	-	WR	-	-	B	R	G	-	BG	BG	BG	-	-	BG	WG	-	BK	B	B	-	BW	Y	OW

FH300 / BLACK

5	6	46	47	48	49	50	51	52	53	54	55	56	57	58
B	WG	-	-	R	WU	GW	GO	-	BG	NR	GW	-	-	Y
3	4	33	34	35	36	37	38	39	40	41	42	43	44	45
B	WG	U	-	YG	WG	-	O	-	U	GO	GU	WG	-	G
20	21	22	23	24	25	26	27	28	29	30	31	32		
WR	Y	-	Y	B	-	-	-	-	-	GO	-	OY		
1	2	7	8	9	10	11	12	13	14	15	16	17	18	19
B	B	BG	BG	-	-	WU	GW	-	-	GR	BW	Y	-	OG

DIESEL POWERTRAIN CONTROL MODULE

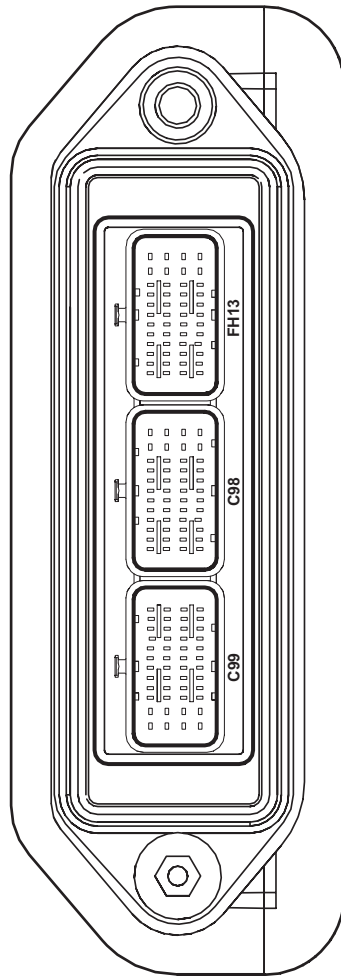

C99 / GREY

M4	L4	K4	J4	H4	G4	F4	E4	D4	C4	B4	A4
BG	GB	BO	GR	YP	WP	NW	WU	WP	WB	WB	WU
M3	L3	K3	J3	H3	G3	F3	E3	D3	C3	B3	A3
BW	GW	SB	WR	NW	NR	NR	WR	—	YR	—	WR
M2	L2	K2	J2	H2	G2	F2	E2	D2	C2	B2	A2
BU	GU	SB	WR	BU	NR	NR	NR	NR	W	U	WR
M1	L1	K1	J1	H1	G1	F1	E1	D1	C1	B1	A1
—	—	BU	GU	GU	YR	WR	W	YG	WG	W	—

C98 / BROWN

A1	B1	C1	D1	E1	F1	G1	H1	J1	K1	L1	M1
W	WR	—	WG	WU	YU	—	WP	GO	N	BY	BO
A2	B2	C2	D2	E2	F2	G2	H2	J2	K2	L2	M2
—	—	—	YG	NG	NU	—	—	—	—	GY	BR
A3	B3	C3	D3	E3	F3	G3	H3	J3	K3	L3	M3
G	—	—	WR	WG	RB	BY	—	GO	BU	GR	GO
A4	B4	C4	D4	E4	F4	G4	H4	J4	K4	L4	M4
Y	—	NR	NY	WB	—	—	—	BU	BR	—	—

FH13 / BLACK

A1	B1	C1	D1	E1	F1	G1	H1	J1	K1	L1	M1
—	GO	BG	B	Y	WP	—	—	—	—	WG	B
A2	B2	C2	D2	E2	F2	G2	H2	J2	K2	L2	M2
B	BG	O	OY	OY	WU	GO	—	BG	WU	WG	B
A3	B3	C3	D3	E3	F3	G3	H3	J3	K3	L3	M3
—	BG	—	OY	OY	U	WG	—	BW	GO	WG	B
A4	B4	C4	D4	E4	F4	G4	H4	J4	K4	L4	M4
—	YG	WG	GR	—	WU	WR	—	BW	NR	B	B

INSTRUMENT CLUSTER

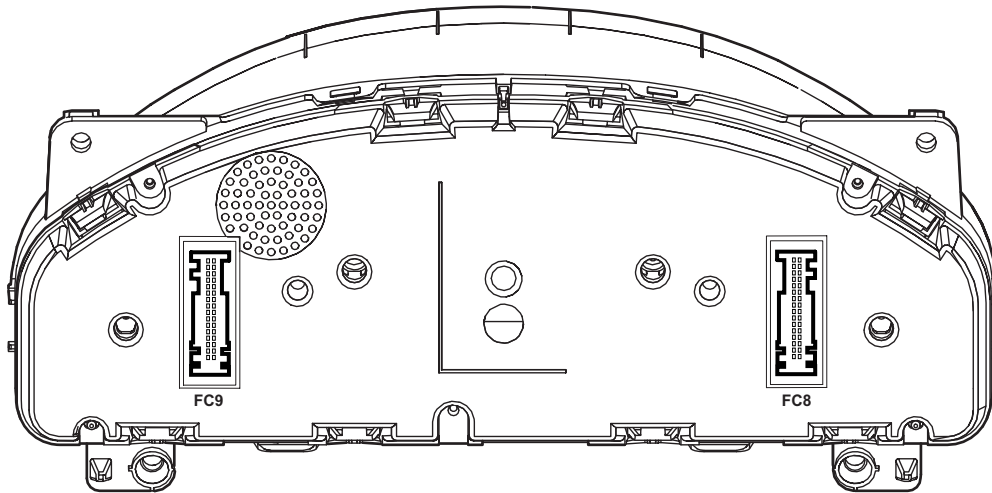

FC9 / BLACK

16	32
YR	WR
15	31
—	BG
14	30
—	—
13	29
G	G
12	28
Y	Y
11	27
U	—
10	26
UY	U
9	25
NG	Y
8	24
GU*	—
7	23
WU	N
6	22
UY	BW
5	21
OY	W
4	20
GW	U
3	19
O	—
2	18
U	W
1	17
GR	OG

Note: *RHD

8

WB

FC8 / BLACK

16	32
—	B
15	31
NG	—
14	30
WG	N
13	29
—	NR
12	28
—	—
11	27
GU	Y
10	26
R	Y
9	25
WR	G
8	24
YR	WG
7	23
GB	BG
6	22
Y	BO
5	21
WU	—
4	20
W	Y
3	19
WB	O
2	18
B	GO
1	17
GW	—

FRONT ELECTRONIC MODULE

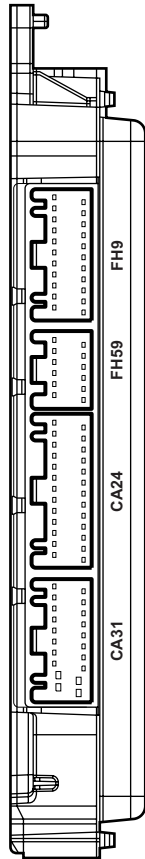

CA31 / BLACK

1	W	2	WR	3	WU	4	—	5	N	6	—	7	BG	8	BW	9	—	10	—
11	O	12	N	13	GW	14	Y	15	—	16	G	17	—	18	N	19	—	20	NW

CA24 / WHITE

1	—	2	—	3	—	4	WG	5	W	6	—	7	WR	8	YR	9	—	10	WU	11	YR	12	Y	13	—
14	—	15	BG	16	—	17	—	18	O	19	WB	20	UY	21	RW	22	NR	23	WB	24	YB	25	—	26	U

FH59 / BLACK

1	U	2	BG	3	W	4	NR	5	BG	6	ING
7	Y	8	NR	9	BG	10	BR	11	—	12	B

FH9 / BLACK

1	NW	2	—	3	ING	4	—	5	—	6	BW	7	BG	8	R	9	—	10	—	11	BW
12	—	13	BG	14	BW	15	WU	16	Y	17	Y	18	—	19	BO	20	—	21	BO	22	BO

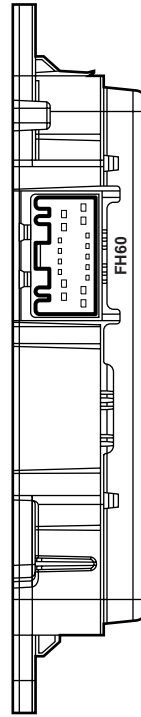

FH60 / BLACK

1	NR	2	NG	3	WG	4	BW	5	BW	6	B	7	—	8	BR		
9	WG	10	BR	11	B	12	—	13	B	14	B	15	B	16	YB	17	BG

REAR ELECTRONIC MODULE

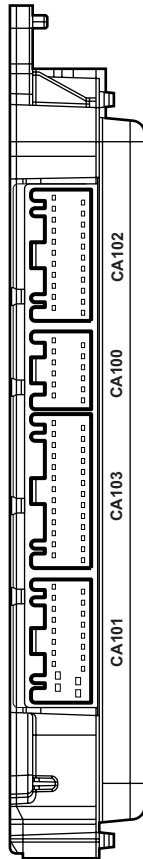

CA101 / BLACK

1	2	3	4	5	6	7	8	9	10
GR	B	N	BO	N	—	—	—	—	—
11	12	13	14	15	16	17	18	19	20
R	Y	—	—	WR	WU	*	BO	BO	BS

CA103 / WHITE

1	2	3	4	5	6	7	8	9	10	11	12	13
—	—	—	YG	Y	W	WB	YU	YU	O	B	B	N
14	15	16	17	18	19	20	21	22	23	24	25	26
—	—	**	—	—	WR	—	—	—	NR	—	B	B

CA100 / BLACK

1	2	3	4	5	6
YG	—	—	—	—	—
7	8	9	10	11	12
—	—	GU	BR	—	—

CA102 / BLACK

1	2	3	4	5	6	7	8	9	10	11
Y	U	G	WU	—	—	—	—	—	—	—
12	13	14	15	16	17	18	19	20	21	22
B	GO	WB	—	—	O	—	—	Y	—	—

* LHD - BG; RHD - BO

** LHD - BO; RHD - BG

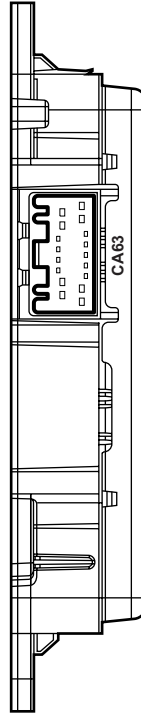

CA63 / BLACK

1	2	3	4	5	6	7	8	
BG	BO	—	—	—	—	—	—	
9	10	11	12	13	14	15	16	17
BG	BR	—	—	—	—	—	—	Y

ELECTRONIC PARKING BRAKE MODULE

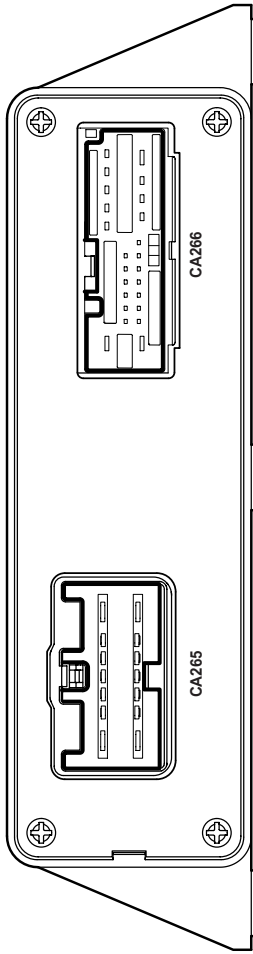

CA265 / GREY

1	—	2	—	3	YG	4	—	5	R	6	N	7	GW
8	—	9	Y	10	Y	11	R	12	Y	13	B	14	RW

CA266 / BLACK

1	NR	2	G	3	G	4	G	5	Y	6	Y	7	WU	8	GO	9	—	10	WG	11	YB	12	B
13	B	14	U	15	GB	16	—	17	—	18	—	19	—	20	—	21	G	22	—	23	—	24	—

DYNAMIC STABILITY CONTROL MODULE

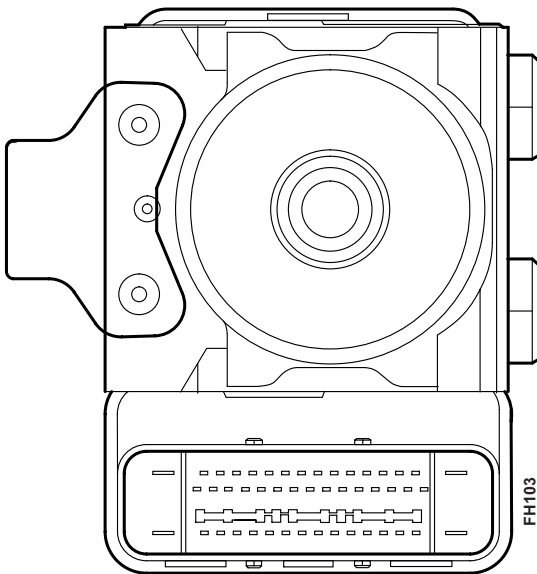

FH103

FH103 / BLACK

1	R	17	—	32	RW	33	WR	34	YR	35	YR	36	N	37	B	38	GU	39	—	40	B	41	G	42	B	43	N	44	—	45	Y	46	W	47	B
2	RU	18	Y	33	WR	34	YR	35	YR	36	N	37	B	38	GU	39	—	40	B	41	G	42	B	43	N	44	—	45	Y	46	W	47	B		
3	—	19	U	34	YR	35	YR	36	N	37	B	38	GU	39	—	40	B	41	G	42	B	43	N	44	—	45	Y	46	W	47	B				
4	—	20	—	35	YR	36	N	37	B	38	GU	39	—	40	B	41	G	42	B	43	N	44	—	45	Y	46	W	47	B						
5	—	21	—	36	N	37	B	38	GU	39	—	40	B	41	G	42	B	43	N	44	—	45	Y	46	W	47	B								
6	—	22	R	37	B	38	GU	39	—	40	B	41	G	42	B	43	N	44	—	45	Y	46	W	47	B										
7	—	23	—	38	GU	39	—	40	B	41	G	42	B	43	N	44	—	45	Y	46	W	47	B												
8	—	24	—	39	—	40	B	41	G	42	B	43	N	44	—	45	Y	46	W	47	B														
9	—	25	—	40	B	41	G	42	B	43	N	44	—	45	Y	46	W	47	B																
10	—	26	GR	41	G	42	B	43	N	44	—	45	Y	46	W	47	B																		
11	Y	27	Y	42	B	43	N	44	—	45	Y	46	W	47	B																				
12	Y	28	Y	43	N	44	—	45	Y	46	W	47	B																						
13	G	29	BK	44	—	45	Y	46	W	47	B																								
14	—	30	GO	45	Y	46	W	47	B																										
15	—	31	—	46	W	47	B																												
16	B	—	—	47	B																														

ADAPTIVE DAMPING CONTROL MODULE

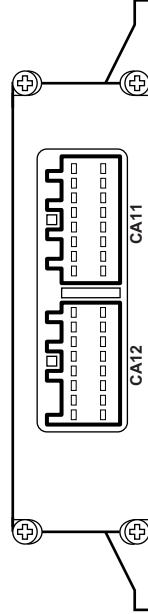

CA12 / GREY

1	—	2	—	3	—	4	—	5	—	6	—	7	—	8	—
9	Y	10	YB	11	WB	12	YR	13	—	14	—	15	—	16	—

CA11 / BLUE

1	WB	2	BG	3	W	4	BO	5	BW	6	WG	7	BG	8	WU
9	N	10	B	11	—	12	NG	13	U	14	Y	15	—	16	NW

AIR CONDITIONING CONTROL MODULE - PANEL

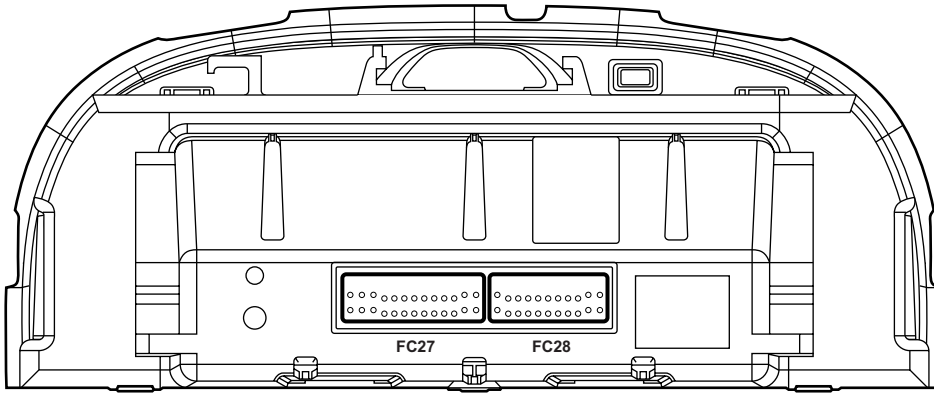

FC27 / GREY

13 WB	12 —	11 —	10 WR	9 YR	8 —	7 NG	6 NG	5 NW	4 WG	3 W	2 —	1 WB
26 YB	25 Y	24 W	23 YU	22 WU	21 WU	20 NR	19 BG	18 NG	17 NR	16 WU	15 WR	14 NR

FC28 / GREY

11 N	10 WR	9 WU	8 NW	7 WR	6 *	5 NG	4 —	3 NR	2 B	1 G
22 Y	21 —	20 GW	19 NG	18 **	17 WU	16 NR	15 —	14 NR	13 —	12 Y

*LHD - WB; RHD - WG
** LHD - WG; RHD - WB

AIR CONDITIONING CONTROL MODULE - REMOTE

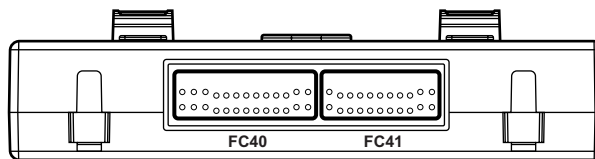

FC40 / GREY

13 WB	12 —	11 —	10 WR	9 YR	8 —	7 NG	6 NG	5 NW	4 WG	3 W	2 —	1 WB
26 YB	25 Y	24 W	23 YU	22 WU	21 WU	20 NR	19 BG	18 NG	17 NR	16 WU	15 WR	14 NR

FC41 / GREY

11 N	10 WR	9 WU	8 NW	7 WR	6 *	5 NG	4 —	3 NR	2 B	1 G
22 Y	21 —	20 GW	19 NG	18 **	17 WU	16 NR	15 UY	14 NR	13 —	12 Y

*LHD - WB; RHD - WG
** LHD - WG; RHD - WB

DRIVER SEAT MODULE

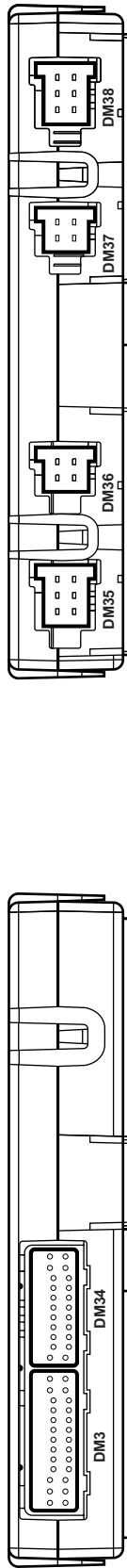

13	12	11	10	9	8	7	6	5	4	3	2	1
NG	Y	WB	R	WU	U	O	—	—	—	—	15	14
26	WB	24	WR	WU	21	20	19	18	17	16	—	—

11	10	9	8	7	6	5	4	3	2	1
GB	RW	—	—	—	—	UY	U	—	13	12
WR	21	20	19	18	17	16	15	14	—	—

6	4	2
NR	—	OG
5	3	1
B	—	GO

4	2
RU	UY
3	1
YR	YU

4	2
U	—
3	1
GU	—

6	4	2
GR	GO	NW
5	3	1
RG	GW	B

DRIVER DOOR MODULE

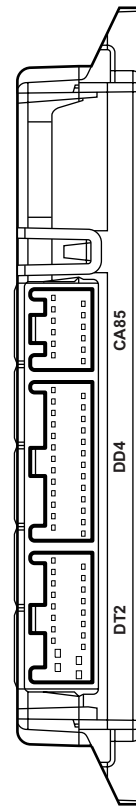

11	12	13	14	15	16	17	18	19	20	21	22	23	24	25	26
—	—	W	WB	YB	BG	EW	GW	NW	—	—	—	—	—	—	—
—	12	13	14	15	16	17	18	19	20	21	22	23	24	25	26
—	WR	YR	—	—	—	—	—	—	—	—	—	—	—	—	—

1	2	3	4	5	6	7	8	9	10	11	12	13
WR	YR	—	UY	—	—	Y	—	—	YR	YU	—	—
—	—	—	—	—	—	—	—	—	—	—	—	—

1	2	3	4	5	6
—	BG	Y	U	WG	YG

7	8	9	10	11	12
B	B	BO	BO	WG	NR

SPEED CONTROL SENSOR

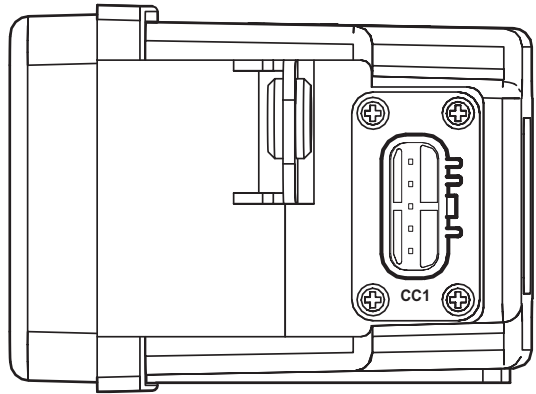

CC1 / BLACK

1	NW
2	B
3	Y
4	G
5	NR

SPEED CONTROL MODULE

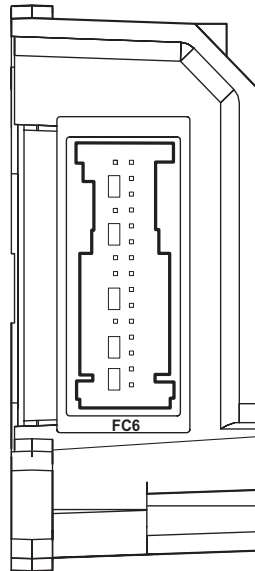

FC6 / YELLOW

15	NR	30	—
14	NW	29	—
13	—	28	—
12	B	27	—
11	—	26	—
10	—	25	—
9	Y	24	Y
8	G	23	G
7	—	22	—
6	—	21	—
5	GW	20	OG
4	—	19	—
3	G	18	—
2	Y	17	—
1	—	16	—

GLOW PLUG CONTROL MODULE

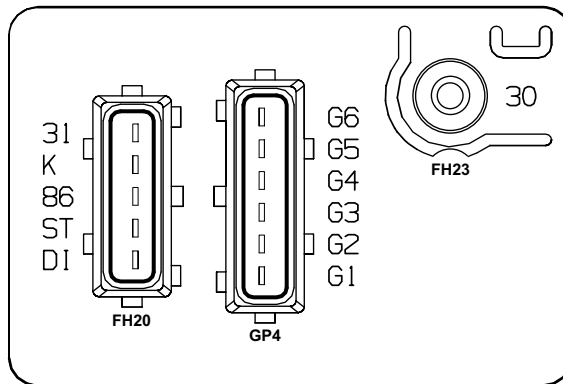

FH20 / BLACK

1	B
2	BW
3	WG
4	—
5	WG

GP4 / BLACK

6	RG
5	RU
4	R
3	RG
2	RU
1	R

FH23

1	R
---	---

FUEL-FIRED AUXILIARY HEATER MODULE

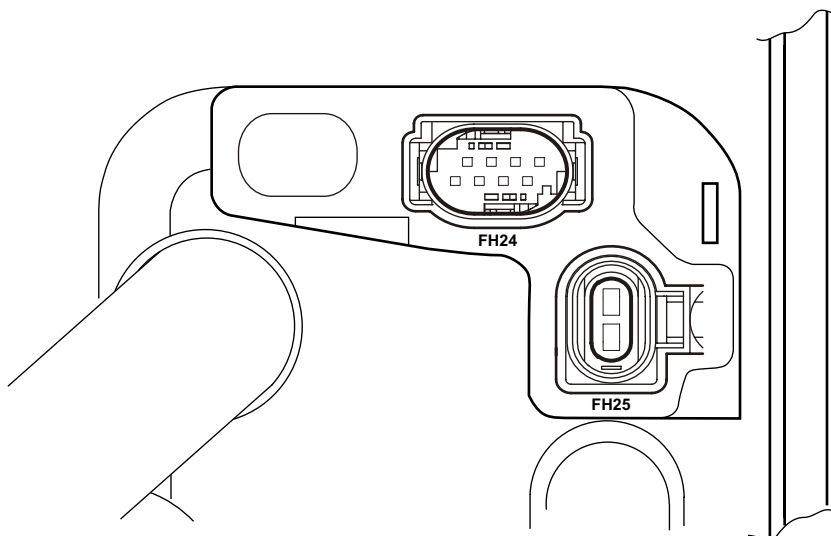

FH24 / BLACK

4	G	3	—	2	—	1	—
8	—	7	Y	6	—	5	RW

FH25 / BLACK

2	B
1	RU

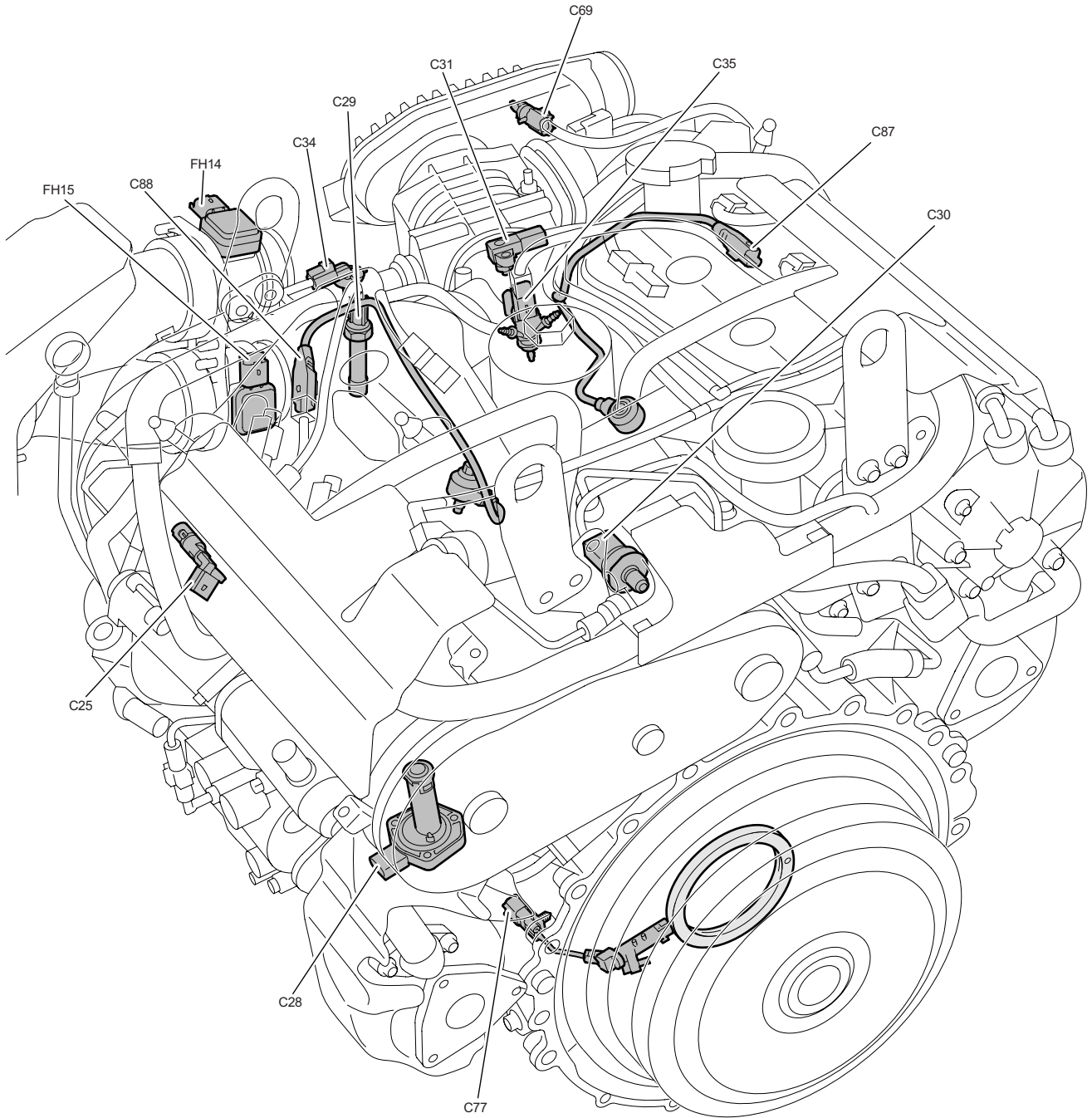

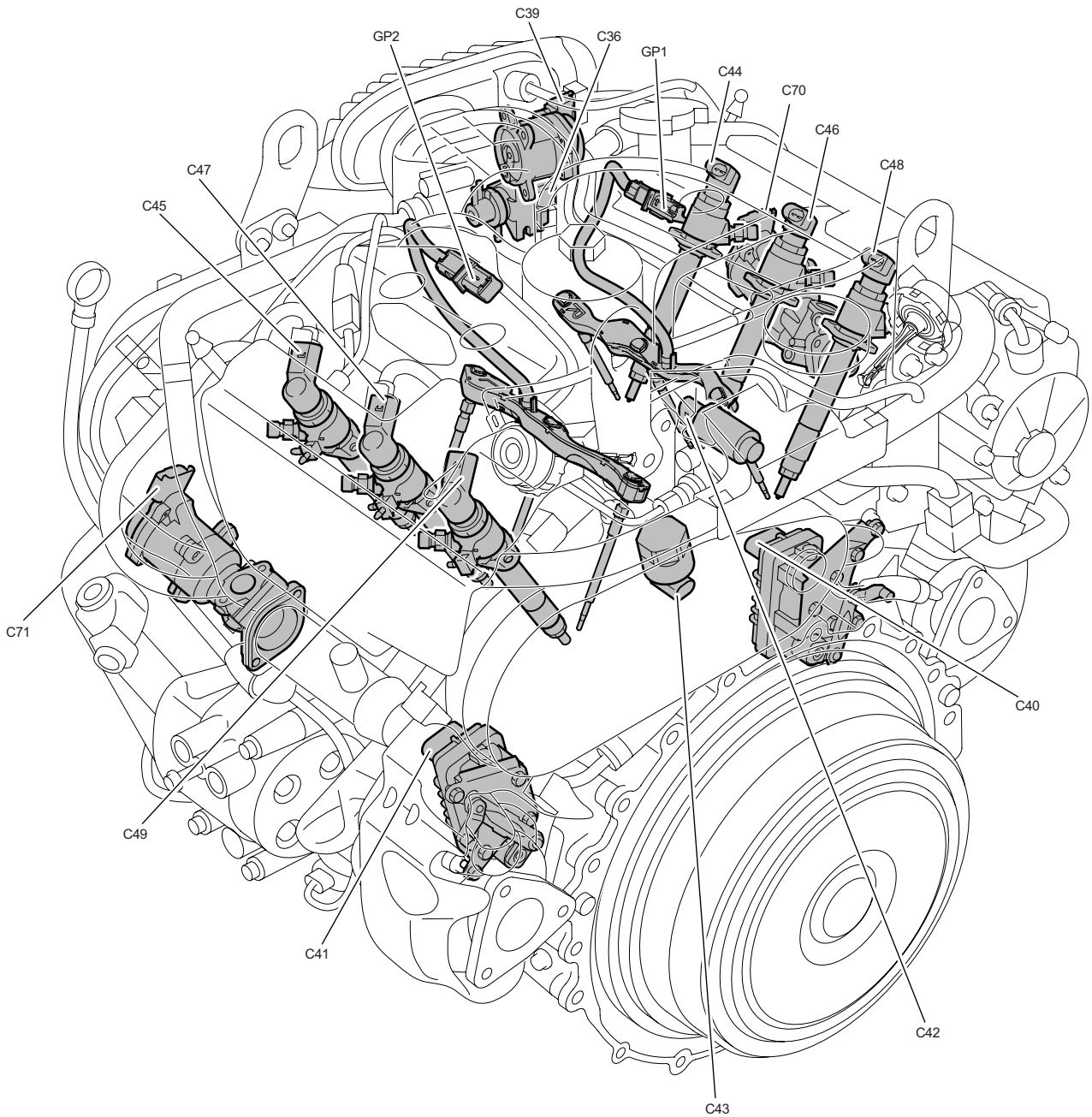

Fig. 01.1

COMPONENTS

Component	Connector(s)	Connector Description	Location
BATTERY	—	—	LUGGAGE COMPARTMENT
FPDB MEGAFUSE	—	—	LUGGAGE COMPARTMENT
FRONT POWER DISTRIBUTION FUSE BOX	—	—	ENGINE COMPARTMENT, RH SIDE
IGNITION SWITCH	FC18	7-WAY / BLACK	STEERING COLUMN COWLING
REAR POWER DISTRIBUTION FUSE BOX	—	—	LUGGAGE COMPARTMENT
REAR POWER DISTRIBUTION FUSE BOX MEGAFUSE	—	—	LUGGAGE COMPARTMENT
STARTER MEGAFUSE	—	—	LUGGAGE COMPARTMENT
TRANSIT ISOLATION RELAY	CA16	2-WAY / WHITE	LUGGAGE COMPARTMENT, BATTERY + POST

HARNESS IN-LINE CONNECTORS

Connector	Connector Description / Location	Location
FC39	10-WAY / GREY / CABIN HARNESS TO FASCIA HARNESS	BEHIND INSTRUMENT PANEL, RH SIDE

GROUNDS

Ground	Location
JB1	LUGGAGE COMPARTMENT, BATTERY GROUND

Refer to the front of this book for detailed information and illustrations regarding the location and identification of harnesses, relays, fuses, grounds, control modules and control module pins.

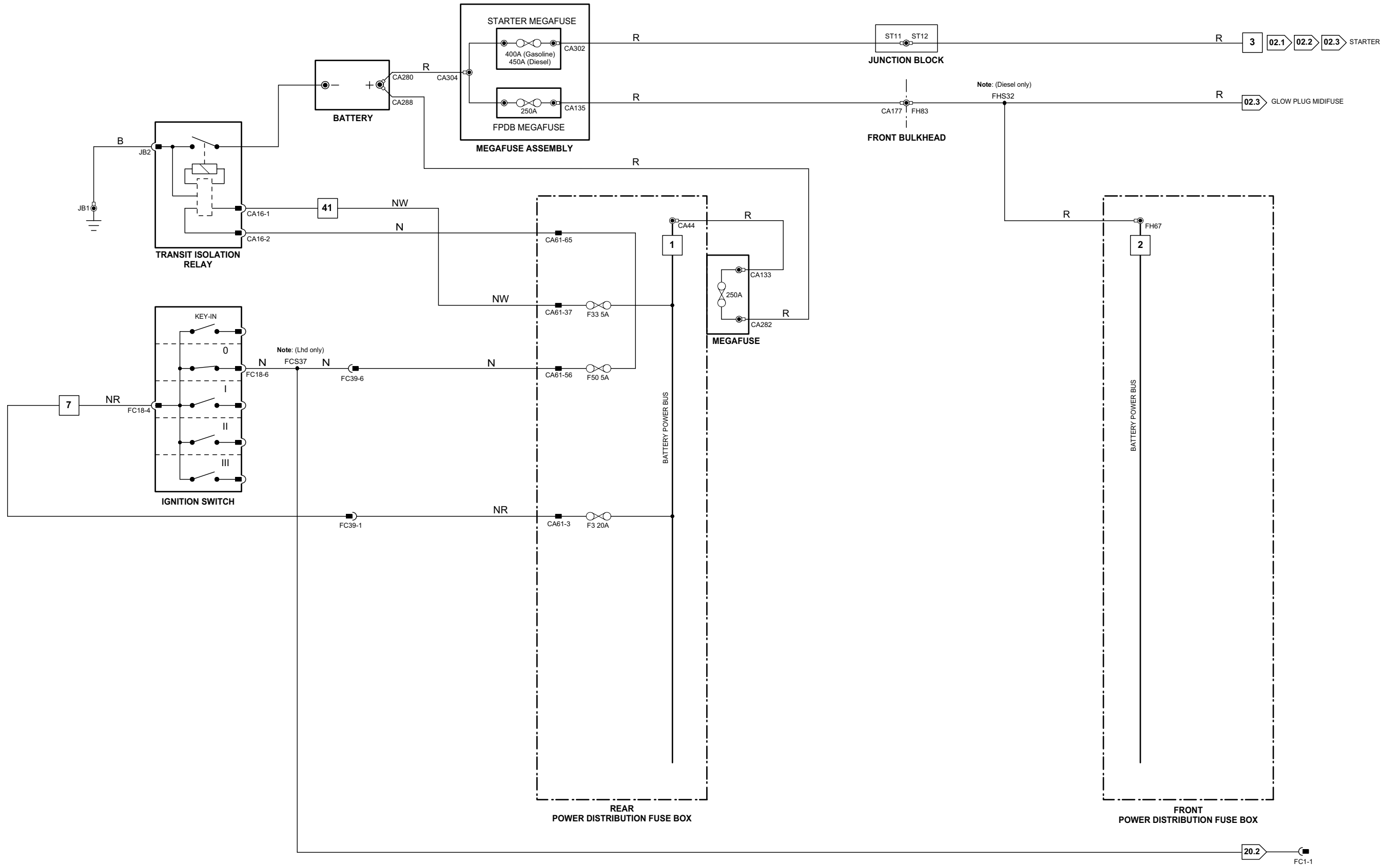

1 → 3
Fig. 01.1

4 → 76
Fig. 01.2

77 → 92
Fig. 01.3

1 → 14
Fig. 01.4

15 → 45
Fig. 01.5

46 → 80
Fig. 01.6

81 → 118
Fig. 01.7

Input
Output

B Battery Voltage
P Power Ground

+ Sensor/Signal Supply V
- Sensor/Signal Ground

C CAN
S SCP

D D2B Network
D Serial and Encoded Data

VARIANT: All Vehicles
VIN RANGE: All
DATE OF ISSUE: April 2006

Fig. 01.2**COMPONENTS**

Component	Connector(s)	Connector Description	Location
FRONT POWER DISTRIBUTION FUSE BOX	—	—	ENGINE COMPARTMENT, RH SIDE
REAR POWER DISTRIBUTION FUSE BOX	—	—	LUGGAGE COMPARTMENT

HARNESS IN-LINE CONNECTORS

Connector	Connector Description / Location	Location
DM22	4-WAY / GREY / CABIN HARNESS TO DRIVER SEAT HARNESS	UNDER DRIVER SEAT
DM23	20-WAY / BLACK / CABIN HARNESS TO DRIVER SEAT HARNESS	UNDER DRIVER SEAT
DT8	14-WAY / GREY / CABIN HARNESS TO DRIVER DOOR TRIM HARNESS	DRIVER DOOR
FC39	10-WAY / GREY / CABIN HARNESS TO FASCIA HARNESS	BEHIND INSTRUMENT PANEL, RH SIDE
FH1	22-WAY / DARK GREY / CABIN HARNESS TO FRONT HARNESS	RH 'A' POST, LOWER
PI41	42-WAY / BLACK / ENGINE HARNESS TO VEHICLE HARNESSES	ENGINE COMPARTMENT, BULKHEAD, PASSENGER SIDE
PN23	4-WAY / GREY / CABIN HARNESS TO PASSENGER SEAT HARNESS	UNDER PASSENGER SEAT
PN24	20-WAY / BLACK / CABIN HARNESS TO PASSENGER SEAT HARNESS	UNDER PASSENGER SEAT
PT1	14-WAY / GREY / CABIN HARNESS TO PASSENGER DOOR TRIM HARNESS	PASSENGER DOOR

Refer to the front of this book for detailed information and illustrations regarding the location and identification of harnesses, relays, fuses, grounds, control modules and control module pins.

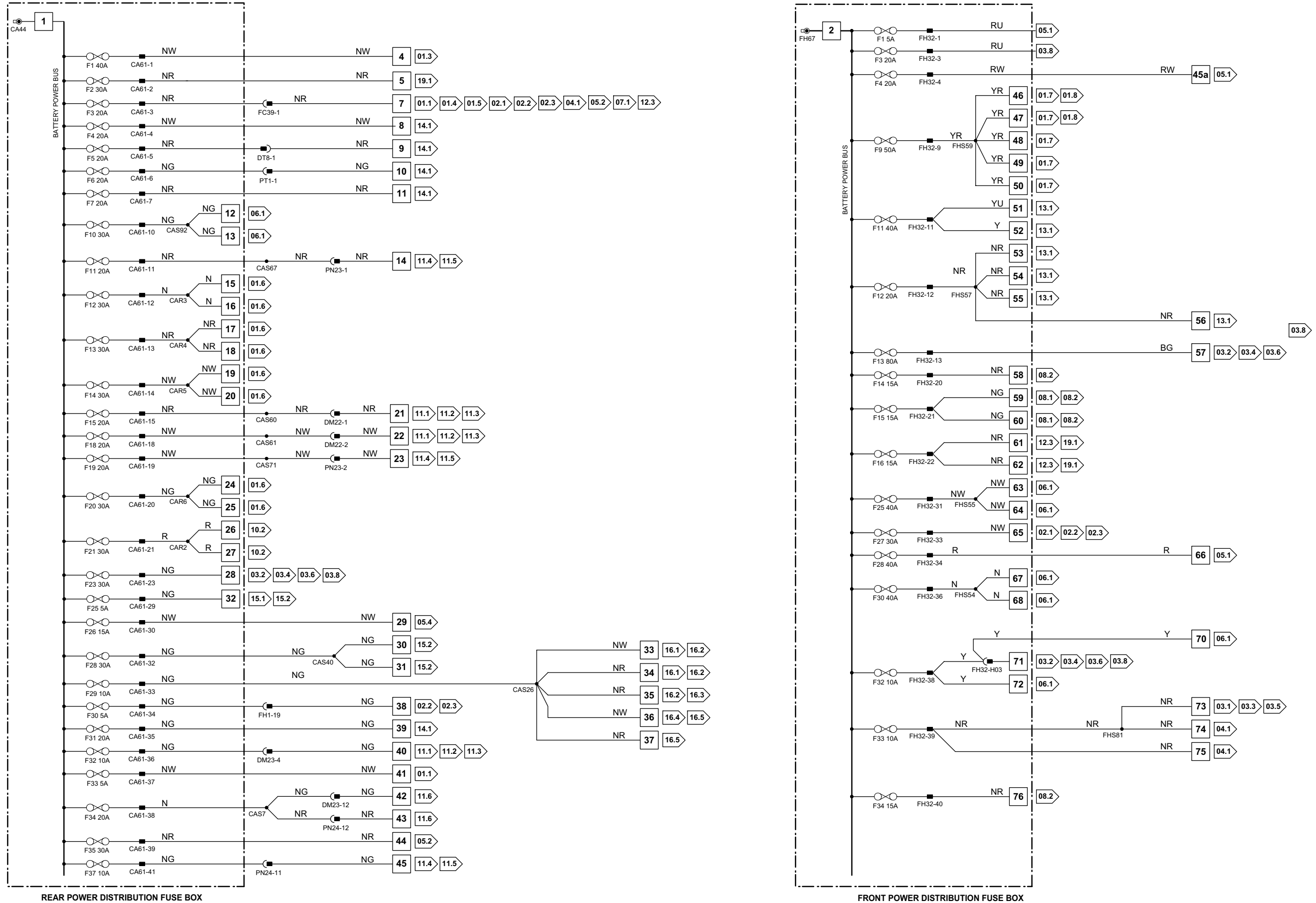

1 → 3
Fig. 01.1

4 → 76
Fig. 01.2

77 → 92
Fig. 01.3

1 → 14
Fig. 01.4

15 → 45
Fig. 01.5

46 → 80
Fig. 01.6

81 → 118
Fig. 01.7

Input
Output

B Battery Voltage
P Power Ground

▽ Sensor/Signal Supply V
▽ Sensor/Signal Ground

▽ CAN
▽ SCP
D2B Network
Serial and Encoded Data

VARIANT: All Vehicles
VIN RANGE: All
DATE OF ISSUE: April 2006

Fig. 01.3**COMPONENTS**

Component	Connector(s)	Connector Description	Location
PRIMARY JUNCTION FUSE BOX	CA2	26-WAY / BLACK	RH 'A' POST
	CA5	8-WAY / BLACK	
	FC37	26-WAY / BLACK	
	FH7	6-WAY / BLACK	
	FH53	10-WAY / BLACK	
REAR POWER DISTRIBUTION FUSE BOX	—	—	LUGGAGE COMPARTMENT

HARNESS IN-LINE CONNECTORS

Connector	Connector Description / Location	Location
FH1	22-WAY / DARK GREY / CABIN HARNESS TO FRONT HARNESS	RH 'A' POST, LOWER
SL3	10-WAY / GREY / FASCIA HARNESS TO SOLAR SENSOR LINK	BEHIND INSTRUMENT PANEL, RH SIDE

Refer to the front of this book for detailed information and illustrations regarding the location and identification of harnesses, relays, fuses, grounds, control modules and control module pins.

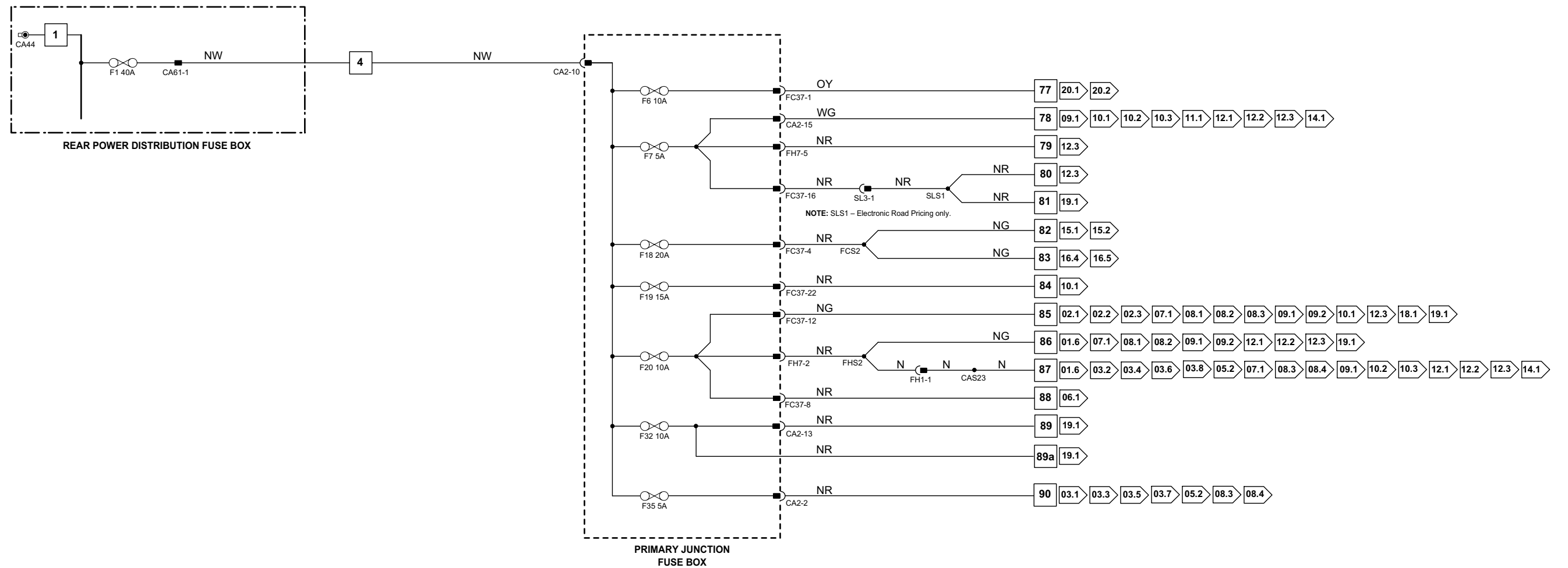

VARIANT: All Vehicles
VIN RANGE: All
DATE OF ISSUE: April 2006

Fig. 01.4

COMPONENTS

Component	Connector(s)	Connector Description	Location
IGNITION SWITCH	FC18	7-WAY / BLACK	STEERING COLUMN COWLING
PRIMARY JUNCTION FUSE BOX	CA2	26-WAY / BLACK	RH 'A' POST
	CA56	8-WAY / BLACK	
	FC37	26-WAY / BLACK	
	FH7	6-WAY / BLACK	
	FH53	10-WAY / BLACK	
REAR POWER DISTRIBUTION FUSE BOX	—	—	LUGGAGE COMPARTMENT

HARNESS IN-LINE CONNECTORS

Connector	Connector Description / Location	Location
FC10	14-WAY / GREEN / FASCIA HARNESS TO FRONT HARNESS	BEHIND INSTRUMENT PANEL, RH SIDE
FC39	10-WAY / GREY / CABIN HARNESS TO FASCIA HARNESS	BEHIND INSTRUMENT PANEL, RH SIDE

Refer to the front of this book for detailed information and illustrations regarding the location and identification of harnesses, relays, fuses, grounds, control modules and control module pins.

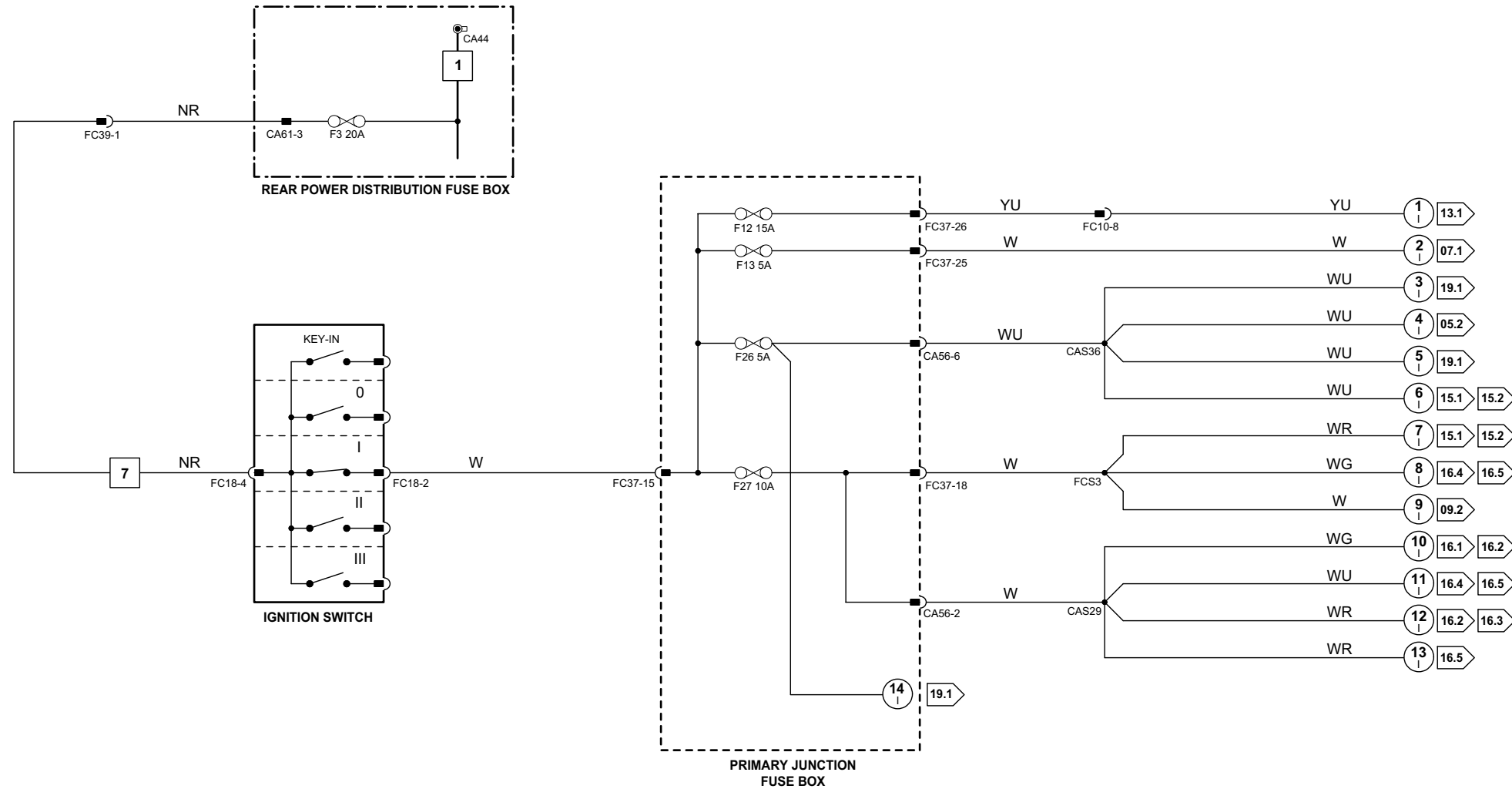

1 → 3
Fig. 01.1

4 → 76
Fig. 01.2

77 → 92
Fig. 01.3

1 → 14
Fig. 01.4

15 → 45
Fig. 01.5

46 → 80
Fig. 01.8

81 → 118
Fig. 01.7

Input
Output

B Battery Voltage
P Power Ground

+ Sensor/Signal Supply V
- Sensor/Signal Ground

C CAN
S SCP
D D2B Network
D Serial and Encoded Data

VARIANT: All Vehicles
VIN RANGE: All
DATE OF ISSUE: April 2006

Fig. 01.5**COMPONENTS**

Component	Connector(s)	Connector Description	Location
FRONT POWER DISTRIBUTION FUSE BOX	—	—	ENGINE COMPARTMENT, RH SIDE
IGNITION SWITCH	FC18	7-WAY / BLACK	STEERING COLUMN COWLING
INERTIA SWITCH	CA4	3-WAY / GREY	LH 'A' POST
PARKING BRAKE MODULE	CA265	14-WAY / GREY	LUGGAGE COMPARTMENT, RH REAR
	CA266	24-WAY / BLACK	
PRIMARY JUNCTION FUSE BOX	CA2	26-WAY / BLACK	RH 'A' POST
	CA56	8-WAY / BLACK	
	FC37	26-WAY / BLACK	
	FH7	6-WAY / BLACK	
	FH53	10-WAY / BLACK	
REAR POWER DISTRIBUTION FUSE BOX	—	—	LUGGAGE COMPARTMENT

HARNES IN-LINE CONNECTORS

Connector	Connector Description / Location	Location
DM23	20-WAY / BLACK / CABIN HARNESS TO DRIVER SEAT HARNESS	UNDER DRIVER SEAT
FC10	14-WAY / GREEN / FASCIA HARNESS TO FRONT HARNESS	BEHIND INSTRUMENT PANEL, RH SIDE
FC39	10-WAY / GREY / CABIN HARNESS TO FASCIA HARNESS	BEHIND INSTRUMENT PANEL, RH SIDE
FH1	22-WAY / DARK GREY / CABIN HARNESS TO FRONT HARNESS	RH 'A' POST, LOWER
GB1	16-WAY / GREY / ENGINE HARNESS TO TRANSMISSION HARNESS	ADJACENT TO TRANSMISSION BELL HOUSING
PI41	42-WAY / BLACK / ENGINE HARNESS TO VEHICLE HARNESSES	ENGINE COMPARTMENT, BULKHEAD, PASSENGER SIDE
PN24	20-WAY / BLACK / CABIN HARNESS TO PASSENGER SEAT HARNESS	UNDER PASSENGER SEAT
RF34	16-WAY / GREEN / CABIN HARNESS TO DOOR HARNESS	'D' POST, UNDER PARCEL SHELF

Refer to the front of this book for detailed information and illustrations regarding the location and identification of harnesses, relays, fuses, grounds, control modules and control module pins.

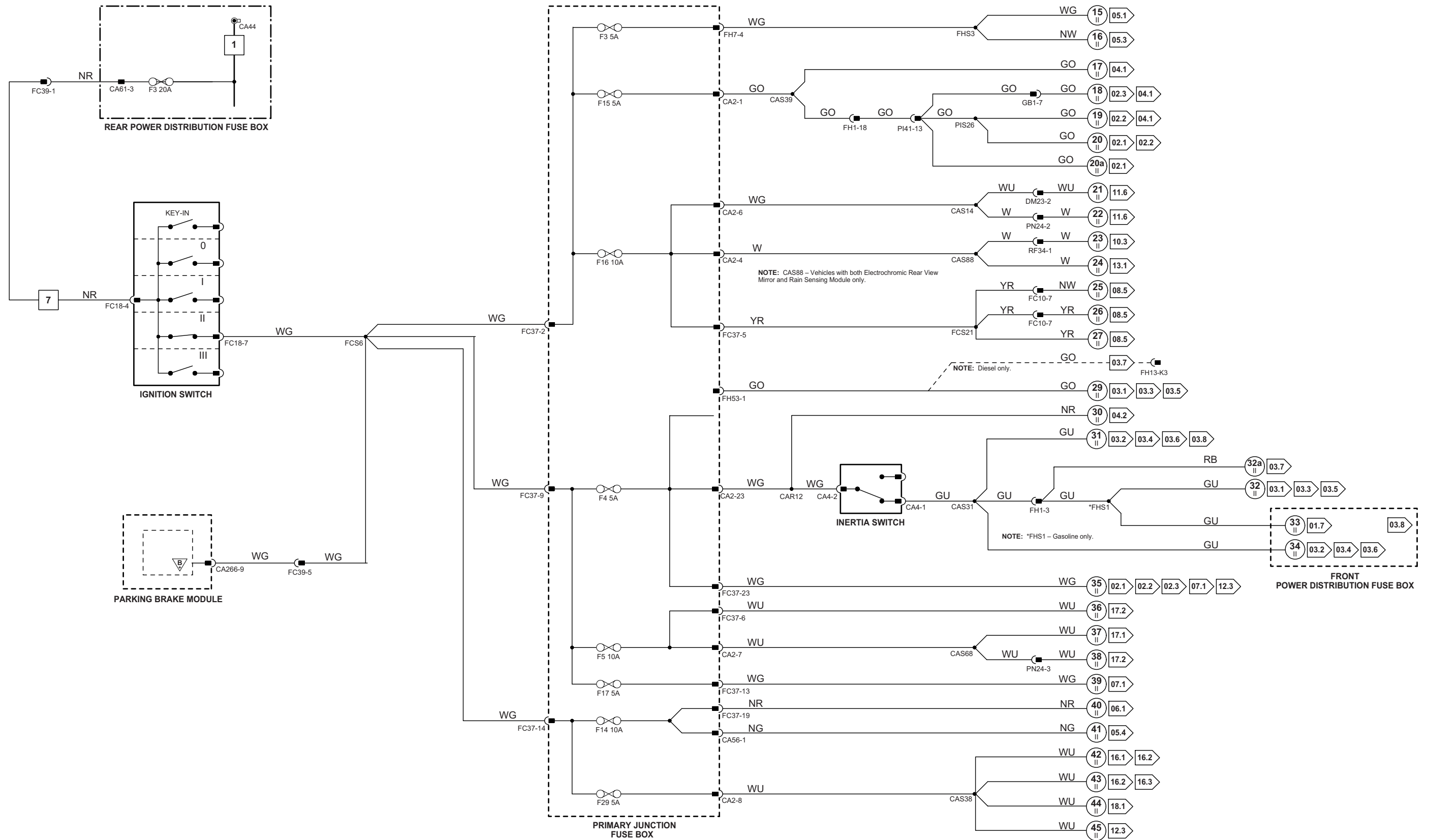

Front Electronic Module

	Pin	Description and Characteristic
O	FH9-21	SWITCHED SYSTEM POWER RELAYS ACTIVATE: TO ACTIVATE, FEM SWITCHES CIRCUIT TO GROUND
S	FH59-1	SCP
B+	FH59-6	BATTERY POWER SUPPLY (LOGIC): B+
S	FH59-7	SCP +
PG	FH60-11	POWER GROUND: GROUND

Rear Electronic Module

	Pin	Description and Characteristic
B+	CA101-3	BATTERY POWER SUPPLY: B+
O	CA101-4	SWITCHED SYSTEM POWER RELAYS ACTIVATE: TO ACTIVATE, REM SWITCHES CIRCUIT TO GROUND
S	CA102-1	SCP +
S	CA102-2	SCP -
PG	CA102-12	POWER GROUND: GROUND

Fig. 01.6

COMPONENTS

Component	Connector(s)	Connector Description	Location
FRONT ELECTRONIC MODULE	CA24	26-WAY / NATURAL	LH 'A' POST
	CA31	20-WAY / BLACK	
	FH9	22-WAY / BLACK	
	FH59	12-WAY / BLACK	
	FH60	17-WAY / BLACK	
	CA2	26-WAY / BLACK	
PRIMARY JUNCTION FUSE BOX	CA56	8-WAY / BLACK	RH 'A' POST
	FC37	26-WAY / BLACK	
	FH7	6-WAY / BLACK	
	FH53	10-WAY / BLACK	
REAR ELECTRONIC MODULE	CA63	17-WAY / BLACK	LUGGAGE COMPARTMENT, RH REAR
	CA100	12-WAY / BLACK	
	CA101	20-WAY / BLACK	
	CA102	22-WAY / BLACK	
	CA103	26-WAY / NATURAL	
REAR POWER DISTRIBUTION FUSE BOX	—	—	LUGGAGE COMPARTMENT
SWITCHED SYSTEM POWER RELAY 1	—	—	REAR POWER DISTRIBUTION FUSE BOX - R2
SWITCHED SYSTEM POWER RELAY 2	—	—	REAR POWER DISTRIBUTION FUSE BOX - R11
SWITCHED SYSTEM POWER RELAY 3	—	—	REAR POWER DISTRIBUTION FUSE BOX - R4
SWITCHED SYSTEM POWER RELAY 4	—	—	REAR POWER DISTRIBUTION FUSE BOX - R5

HARNESS IN-LINE CONNECTORS

Connector	Connector Description / Location	Location
BF1	6-WAY / GREY / FRONT HARNESS TO FRONT BUMPER HARNESS	BEHIND FRONT BUMPER, LH SIDE
BR1	10-WAY / GREY / CABIN HARNESS TO REAR BUMPER HARNESS	BEHIND REAR BUMPER, RH SIDE
FC33	16-WAY / GREEN / CABIN HARNESS TO FASCIA HARNESS	BEHIND INSTRUMENT PANEL, RH SIDE
FH6	16-WAY GREEN / CABIN HARNESS TO FRONT HARNESS	LH 'A' POST, ADJACENT TO FEM
FH39	12-WAY / GREY / FRONT HARNESS TO RH FRONT HEADLAMP LINK	BEHIND FRONT BUMPER, RH SIDE
FH40	12-WAY / GREY / FRONT HARNESS TO LH FRONT HEADLAMP LINK	BEHIND FRONT BUMPER, LH SIDE
RF34	16-WAY / GREEN / CABIN HARNESS TO DOOR HARNESS	'D' POST, UNDER PARCEL SHELF
TT1	6-WAY / GREY / TRAILER TOWING IN-LINE CONNECTOR	LUGGAGE COMPARTMENT, ADJACENT TO RH TAIL LAMP

GROUNDINGS

Ground	Location
CA156	LUGGAGE COMPARTMENT, RH SIDE
FH77	LH LOWER 'A' POST, ADJACENT TO THE GENERAL ELECTRONIC CONTROL MODULE (FORWARD OF CA30)

FOR CONTROL MODULE PIN-OUT INFORMATION, UNFOLD PAGE TO LEFT.

The following abbreviations are used to represent values for Control Module Pin-Out data

I	Input	PG	Power Ground	C	CAN Network	D	Serial and Encoded Data
O	Output	SS	Sensor / Signal Supply V	S	SCP Network	V	Voltage (DC)
B+	Battery Voltage	SG	Sensor / Signal Ground	D2	D2B Network	PWM	Pulse Width Modulated

CAUTION: The information on this data page is furnished to aid the user in understanding circuit operation. THIS INFORMATION SHOULD BE USED FOR REFERENCE ONLY.

NOTE: The values listed are approximately those that can be expected at the control module connector pins with all circuit connections made and all components connected and fitted.

Refer to the front of this book for detailed information and illustrations regarding the location and identification of harnesses, relays, fuses, grounds, control modules and control module pins.

SCP NOTE: The switched system power relays are activated by the FEM or the REM whenever messages are present on the SCP network. After the ignition is switched off, the relays remain activated until all SCP messages are removed.

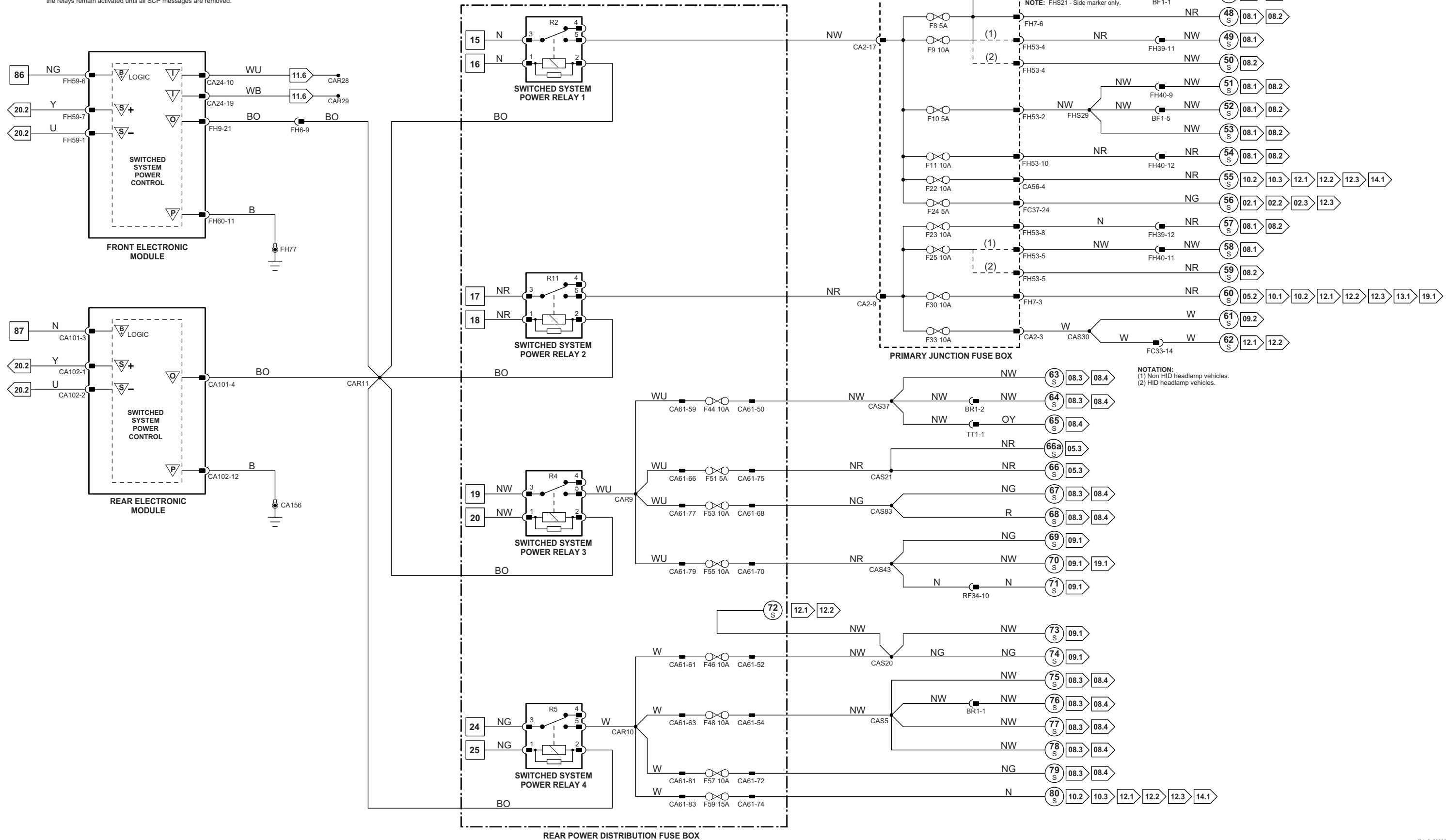

NOTATION:
 (1) Non HID headlamp vehicles.
 (2) HID headlamp vehicles.

1 → 3 Fig. 01.1	4 → 76 Fig. 01.2	77 → 92 Fig. 01.3	1 → 14 Fig. 01.4	15 → 45 Fig. 01.5	46 → 80 Fig. 01.6	81 → 118 Fig. 01.7	Input	Battery Voltage	Sensor/Signal Supply V	CAN	D2B Network
			Output	Power Ground	Sensor/Signal Ground	SCP	Serial and Encoded Data				

VARIANT: All Vehicles
 VIN RANGE: All
 DATE OF ISSUE: April 2006

Engine Control Module

Pin	Description and Characteristic
O FH300-16	EMS CONTROL RELAY DRIVE: TO ACTIVATE, ECM SWITCHES CIRCUIT TO GROUND

Fig. 01.7

COMPONENTS

Component	Connector(s)	Connector Description	Location
EMS CONTROL RELAY	—	—	FRONT POWER DISTRIBUTION FUSE BOX – R4
ENGINE CONTROL MODULE	FH300 PI300	58-WAY / BLACK 96-WAY / BLACK	FRONT BULKHEAD, PASSENGER SIDE
FRONT POWER DISTRIBUTION FUSE BOX	—	—	ENGINE COMPARTMENT, RH SIDE
HO2S RELAY	—	—	FRONT POWER DISTRIBUTION FUSE BOX – R2
IGNITION COIL RELAY	—	—	FRONT POWER DISTRIBUTION FUSE BOX – R3
INTERCOOLER PUMP RELAY	—	—	FRONT POWER DISTRIBUTION FUSE BOX – R9

HARNESS IN-LINE CONNECTORS

Connector	Connector Description / Location	Location
CP1	10-WAY / BLACK / INTERCOOLER PUMP LINK LEAD	ENGINE COMPARTMENT, RH FRONT, ADJACENT TO RADIATOR
IL10	12-WAY / BLACK / ENGINE HARNESS TO FUEL INJECTOR LINK	REAR OF ENGINE
IS5	6-WAY / BLACK / ENGINE HARNESS TO FUEL INJECTOR LINK	ENGINE, LH REAR
IS6	6-WAY / BLACK / ENGINE HARNESS TO FUEL INJECTOR LINK	ENGINE, RH REAR
PI41	42-WAY / BLACK / ENGINE HARNESS TO VEHICLE HARNESSES	ENGINE COMPARTMENT, BULKHEAD, PASSENGER SIDE

GROUNDS

Ground	Location
FH42	ENGINE COMPARTMENT, BEHIND RH HEADLAMP

FOR CONTROL MODULE PIN-OUT INFORMATION, UNFOLD PAGE TO LEFT.

The following abbreviations are used to represent values for Control Module Pin-Out data

I	Input	PG	Power Ground	C	CAN Network	D	Serial and Encoded Data
O	Output	SS	Sensor / Signal Supply V	S	SCP Network	V	Voltage (DC)
B+	Battery Voltage	SG	Sensor / Signal Ground	D2	D2B Network	PWM	Pulse Width Modulated

CAUTION: The information on this data page is furnished to aid the user in understanding circuit operation. THIS INFORMATION SHOULD BE USED FOR REFERENCE ONLY.

NOTE: The values listed are approximately those that can be expected at the control module connector pins with all circuit connections made and all components connected and fitted.

Refer to the front of this book for detailed information and illustrations regarding the location and identification of harnesses, relays, fuses, grounds, control modules and control module pins.

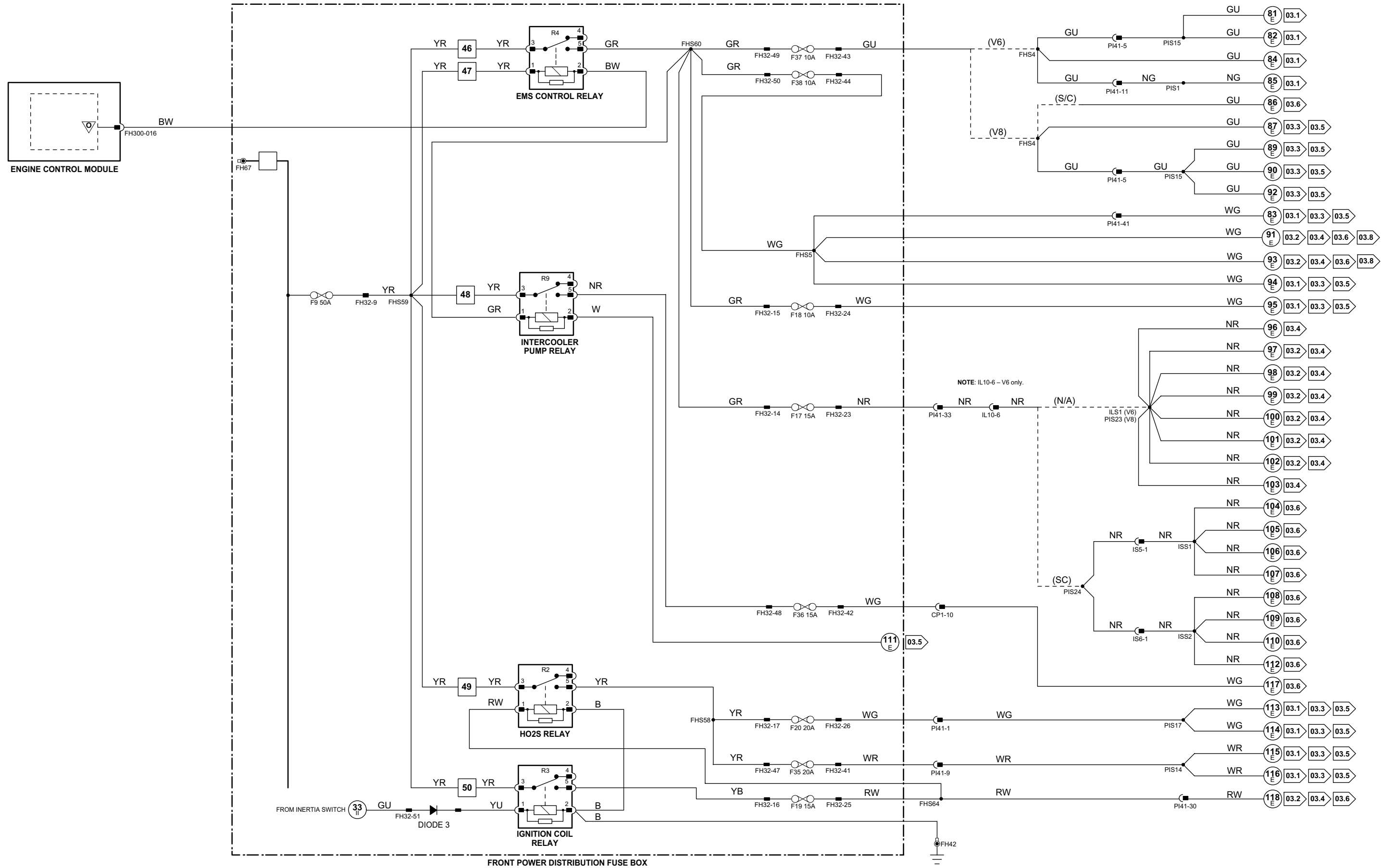

1 → 3 Fig. 01.1	4 → 76 Fig. 01.2	77 → 92 Fig. 01.3	1 → 14 Fig. 01.4	15 → 45 Fig. 01.5	46 → 80 Fig. 01.6	81 → 118 Fig. 01.7	Input	Battery Voltage	Sensor/Signal Supply V	CAN	D2B Network
							Output	Power Ground	Sensor/Signal Ground	SCP	Serial and Encoded Data

VARIANT: Gasoline Vehicles
VIN RANGE: All
DATE OF ISSUE: April 2006

Powertrain Control Module

Pin	Description and Characteristic
O FH13-J3	EMS CONTROL RELAY DRIVE: TO ACTIVATE, ECM SWITCHES CIRCUIT TO GROUND

Fig. 01.8

COMPONENTS

Component	Connector(s)	Connector Description	Location
EMS CONTROL RELAY	—	—	FRONT POWER DISTRIBUTION FUSE BOX – R1
FRONT POWER DISTRIBUTION FUSE BOX	—	—	ENGINE COMPARTMENT, RH SIDE
POWERTRAIN CONTROL MODULE	C98	48-WAY / BROWN	FRONT BULKHEAD, PASSENGER SIDE
	C99	48-WAY / GREY	
	FH13	48-WAY / BLACK	

FOR CONTROL MODULE PIN-OUT INFORMATION, UNFOLD PAGE TO LEFT.

The following abbreviations are used to represent values for Control Module Pin-Out data

I	Input	PG	Power Ground	C	CAN Network	D	Serial and Encoded Data
O	Output	SS	Sensor / Signal Supply V	S	SCP Network	V	Voltage (DC)
B+	Battery Voltage	SG	Sensor / Signal Ground	D2	D2B Network	PWM	Pulse Width Modulated

CAUTION: The information on this data page is furnished to aid the user in understanding circuit operation. THIS INFORMATION SHOULD BE USED FOR REFERENCE ONLY.

NOTE: The values listed are approximately those that can be expected at the control module connector pins with all circuit connections made and all components connected and fitted.

Refer to the front of this book for detailed information and illustrations regarding the location and identification of harnesses, relays, fuses, grounds, control modules and control module pins.

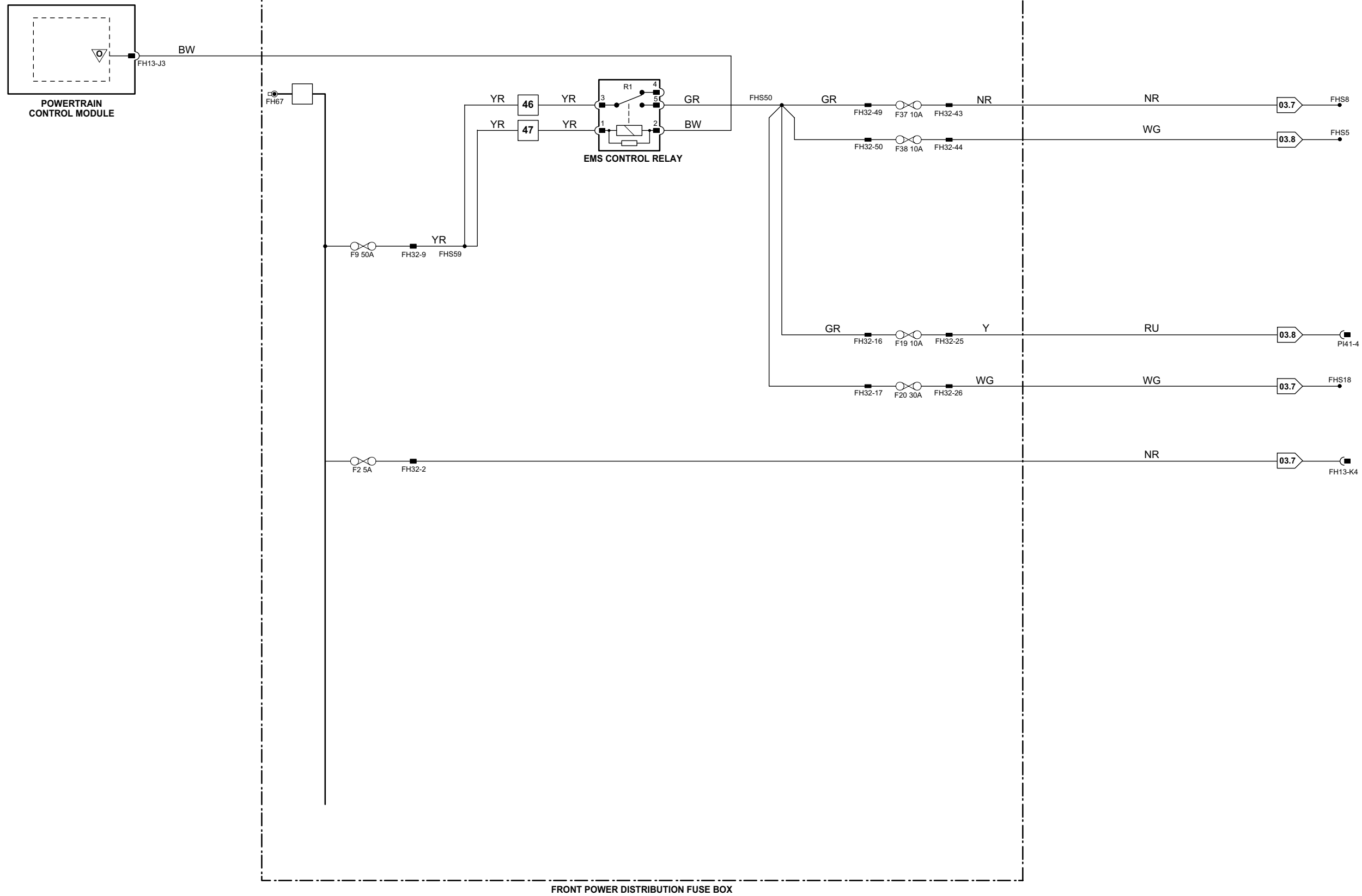

Fig. 02.1

Engine Control Module

	Pin	Description and Characteristic
I	FH300-3	GENERATOR FIELD RETURN SIGNAL: VARIABLE VOLTAGE BY GENERATOR OPERATING CONDITION
I	FH300-15	AUTOMATIC - PARK / NEUTRAL SIGNAL: B+ WHEN ACTIVATED MANUAL, ROW - PARK / NEUTRAL SIGNAL: B+ WHEN IGNITION CRANK (III)
I	FH300-16	GENERATOR FAULT; CHARGE WARNING
I	FH300-17	ENGINE CRANK: B+
C	FH300-45	CAN -
O	FH300-51	STARTER RELAY DRIVE: TO ACTIVATE, ECM SWITCHES CIRCUIT TO GROUND
C	FH300-58	CAN +
O	FH300-96	FUEL PUMP 2 DRIVE (TO FUEL PUMP 2 MODULE): PWM, 150 Hz, NORMAL POSITIVE DUTY CYCLE RANGE = 4% - 51%

Instrument Cluster

	Pin	Description and Characteristic
PG	FC8-2	POWER GROUND: GROUND
I	FC8-5	KEY-IN AUDIBLE WARNING: B+ WHEN KEY IN
B+	FC8-14	IGNITION SWITCHED POWER SUPPLY (II): B+
B+	FC8-15	BATTERY POWER SUPPLY (LOGIC): B+
SG	FC8-32	SIGNAL GROUND: GROUND
D	FC9-16	PATS TRANSCIEVER: ENCODED COMMUNICATION
C	FC9-28	CAN +
C	FC9-29	CAN -
I	FC9-31	PATS GROUND: GROUND
D	FC9-32	PATS TRANSCIEVER: ENCODED COMMUNICATION

Transmission Control Module

	Pin	Description and Characteristic
B+	GB2-9	IGNITION SWITCHED POWER SUPPLY: B+
O	GB2-10	PARK / NEUTRAL SIGNAL: GROUND WHEN ACTIVATED
PG	GB2-13	POWER GROUND: GROUND
PG	GB2-16	POWER GROUND: GROUND

COMPONENTS

Component	Connector(s)	Connector Description	Location
BATTERY	-	-	LUGGAGE COMPARTMENT
ENGINE CONTROL MODULE	FH300 PI300	58-WAY / BLACK 96-WAY / BLACK	FRONT BULKHEAD, PASSENGER SIDE
FPDB MEGAFUSE	-	-	LUGGAGE COMPARTMENT, RH SIDE
FRONT POWER DISTRIBUTION FUSE BOX	-	-	ENGINE COMPARTMENT, RH SIDE
GENERATOR	PI47 ST7	4-WAY / BLACK EYELET	ENGINE, RH SIDE, FRONT
IGNITION SWITCH	FC18	7-WAY / BLACK	STEERING COLUMN COWLING
INSTRUMENT CLUSTER	FC8 FC9	32-WAY / BLACK 32-WAY / BLACK	INSTRUMENT PANEL
PASSIVE ANTI-THEFT SYSTEM TRANSCIEVER	FC52	4-WAY / GREEN	STEERING COLUMN, IGNITION SWITCH
PRIMARY JUNCTION FUSE BOX	CA2 CA56 FC37 FH7 FH53	26-WAY / BLACK 8-WAY / BLACK 26-WAY / BLACK 6-WAY / BLACK 10-WAY / BLACK	RH 'A' POST
STARTER MEGAFUSE	-	-	LUGGAGE COMPARTMENT, RH SIDE
STARTER MOTOR	-	-	ENGINE BLOCK, RH SIDE
STARTER RELAY	-	-	FRONT POWER DISTRIBUTION FUSE BOX - R20
TRANSMISSION CONTROL MODULE	GB2	16-WAY / BLACK	TRANSMISSION CONTROL VALVE ASSEMBLY

HARNESS IN-LINE CONNECTORS

Connector	Connector Description / Location	Location
GB1	16-WAY / GREY / ENGINE HARNESS TO TRANSMISSION HARNESS	ADJACENT TO TRANSMISSION BELL HOUSING
PI41	42-WAY / BLACK / ENGINE HARNESS TO VEHICLE HARNESSES	ENGINE COMPARTMENT, BULKHEAD, PASSENGER SIDE

GROUNDS

Ground	Location
FC38	UNDER CENTER OF INSTRUMENT PANEL, ON TRANSMISSION TUNNEL
JB1	LUGGAGE COMPARTMENT, BATTERY GROUND
PI40 (LHD)	ENGINE COMPARTMENT, BEHIND RH WHEEL ARCH LINER
PI40 (RHD)	ENGINE COMPARTMENT, BEHIND LH WHEEL ARCH LINER
ST2	ENGINE COMPARTMENT, BEHIND LH WHEEL ARCH LINER

FOR CONTROL MODULE PIN-OUT INFORMATION, UNFOLD PAGE TO LEFT.

The following abbreviations are used to represent values for Control Module Pin-Out data

I	Input	PG	Power Ground	C	CAN Network	D	Serial and Encoded Data
O	Output	SS	Sensor / Signal Supply V	S	SCP Network	V	Voltage (DC)
B+	Battery Voltage	SG	Sensor / Signal Ground	D2	D2B Network	PWM	Pulse Width Modulated

CAUTION: The information on this data page is furnished to aid the user in understanding circuit operation. THIS INFORMATION SHOULD BE USED FOR REFERENCE ONLY.

NOTE: The values listed are approximately those that can be expected at the control module connector pins with all circuit connections made and all components connected and fitted.

Refer to the front of this book for detailed information and illustrations regarding the location and identification of harnesses, relays, fuses, grounds, control modules and control module pins.

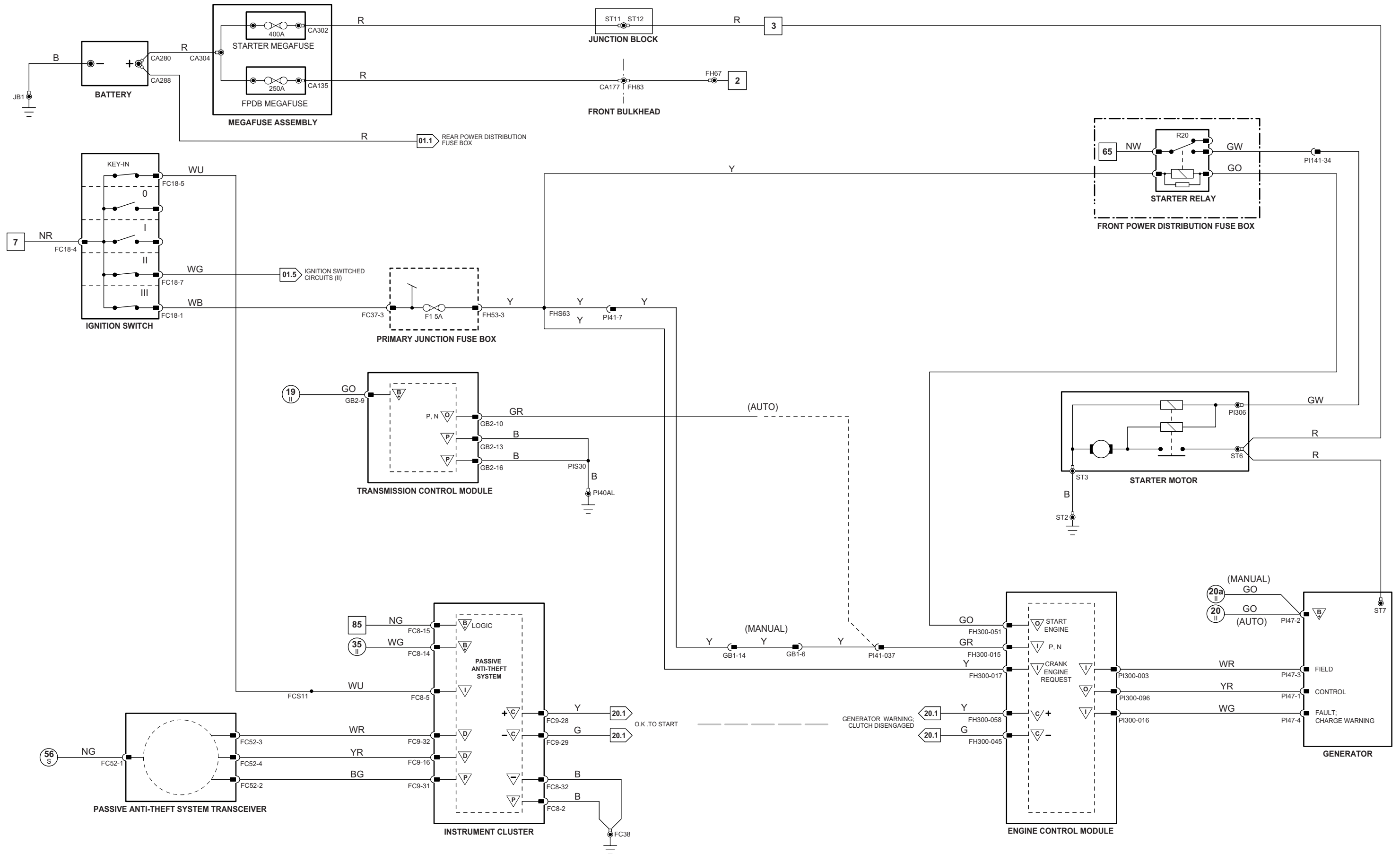

1 → 3 Fig. 01.1	4 → 76 Fig. 01.2	77 → 92 Fig. 01.3	1 → 14 Fig. 01.4	15 → 45 Fig. 01.5	46 → 80 Fig. 01.6	81 → 118 Fig. 01.7	Input Output	Battery Voltage Power Ground	Sensor/Signal Supply V Sensor/Signal Ground	CAN SCP	D2B Network Serial and Encoded Data
--------------------	---------------------	----------------------	---------------------	----------------------	----------------------	-----------------------	-----------------	---------------------------------	--	------------	--

VARIANT: V6 Vehicles
 VIN RANGE: All
 DATE OF ISSUE: April 2006

Engine Control Module

	Pin	Description and Characteristic
I	FH300-15	AUTOMATIC - PARK / NEUTRAL SIGNAL: B+ WHEN ACTIVATED MANUAL, ROW - PARK / NEUTRAL SIGNAL: B+ WHEN IGNITION CRANK (III)
I	FH300-16	GENERATOR FAULT; CHARGE WARNING
I	FH300-17	ENGINE CRANK: B+
C	FH300-45	CAN -
O	FH300-51	STARTER RELAY DRIVE: TO ACTIVATE, ECM SWITCHES CIRCUIT TO GROUND
C	FH300-58	CAN +

Instrument Cluster

	Pin	Description and Characteristic
PG	FC8-2	POWER GROUND: GROUND
I	FC8-5	KEY-IN AUDIBLE WARNING: B+ WHEN KEY IN
B+	FC8-14	IGNITION SWITCHED POWER SUPPLY (II): B+
B+	FC8-15	BATTERY POWER SUPPLY (LOGIC): B+
SG	FC8-32	SIGNAL GROUND: GROUND
D	FC9-16	PATS TRANSCIEVER: ENCODED COMMUNICATION
C	FC9-28	CAN +
C	FC9-29	CAN -
I	FC9-31	PATS GROUND: GROUND
D	FC9-32	PATS TRANSCIEVER: ENCODED COMMUNICATION

Transmission Control Module

	Pin	Description and Characteristic
B+	GB2-9	IGNITION SWITCHED POWER SUPPLY: B+
O	GB2-10	PARK / NEUTRAL SIGNAL: GROUND WHEN ACTIVATED
PG	GB2-13	POWER GROUND: GROUND
PG	GB2-16	POWER GROUND: GROUND

Fig. 02.2

COMPONENTS

Component	Connector(s)	Connector Description	Location
BATTERY	—	—	LUGGAGE COMPARTMENT
ENGINE CONTROL MODULE	FH300 PI300	58-WAY / BLACK 96-WAY / BLACK	FRONT BULKHEAD, PASSENGER SIDE
FPDB MEGAFUSE	—	—	ENGINE COMPARTMENT, RH SIDE
FRONT POWER DISTRIBUTION FUSE BOX	—	—	ENGINE COMPARTMENT, RH SIDE
GENERATOR	PI48 ST7	4-WAY / BLACK EYELET	ENGINE, RH SIDE, FRONT
IGNITION SWITCH	FC18	7-WAY / BLACK	STEERING COLUMN COWLING
INSTRUMENT CLUSTER	FC8 FC9	32-WAY / BLACK 32-WAY / BLACK	INSTRUMENT PANEL
PASSIVE ANTI-THEFT SYSTEM TRANSCIEVER	FC52	4-WAY / GREEN	STEERING COLUMN, IGNITION SWITCH
PRIMARY JUNCTION FUSE BOX	CA2 CA56 FC37 FH7 FH53	26-WAY / BLACK 8-WAY / BLACK 26-WAY / BLACK 6-WAY / BLACK 10-WAY / BLACK	RH 'A' POST
STARTER MEGAFUSE	—	—	LUGGAGE COMPARTMENT, RH SIDE
STARTER MOTOR	—	—	ENGINE BLOCK, RH SIDE
STARTER RELAY	—	—	FRONT POWER DISTRIBUTION FUSE BOX - R20
TRANSMISSION CONTROL MODULE	GB2	16-WAY / BLACK	TRANSMISSION CONTROL VALVE ASSEMBLY

HARNESS IN-LINE CONNECTORS

Connector	Connector Description / Location	Location
PI41	42-WAY / BLACK / ENGINE HARNESS TO VEHICLE HARNESSES	ENGINE COMPARTMENT, BULKHEAD, PASSENGER SIDE

GROUNDS

Ground	Location
FC38	UNDER CENTER OF INSTRUMENT PANEL, ON TRANSMISSION TUNNEL
JB1	LUGGAGE COMPARTMENT, BATTERY GROUND
PI40 (LHD)	ENGINE COMPARTMENT, BEHIND RH WHEEL ARCH LINER
PI40 (RHD)	ENGINE COMPARTMENT, BEHIND LH WHEEL ARCH LINER
ST2	ENGINE COMPARTMENT, BEHIND LH WHEEL ARCH LINER

FOR CONTROL MODULE PIN-OUT INFORMATION, UNFOLD PAGE TO LEFT.

The following abbreviations are used to represent values for Control Module Pin-Out data

I	Input	PG	Power Ground	C	CAN Network	D	Serial and Encoded Data
O	Output	SS	Sensor / Signal Supply V	S	SCP Network	V	Voltage (DC)
B+	Battery Voltage	SG	Sensor / Signal Ground	D2	D2B Network	PWM	Pulse Width Modulated

CAUTION: The information on this data page is furnished to aid the user in understanding circuit operation. THIS INFORMATION SHOULD BE USED FOR REFERENCE ONLY.

NOTE: The values listed are approximately those that can be expected at the control module connector pins with all circuit connections made and all components connected and fitted.

Refer to the front of this book for detailed information and illustrations regarding the location and identification of harnesses, relays, fuses, grounds, control modules and control module pins.

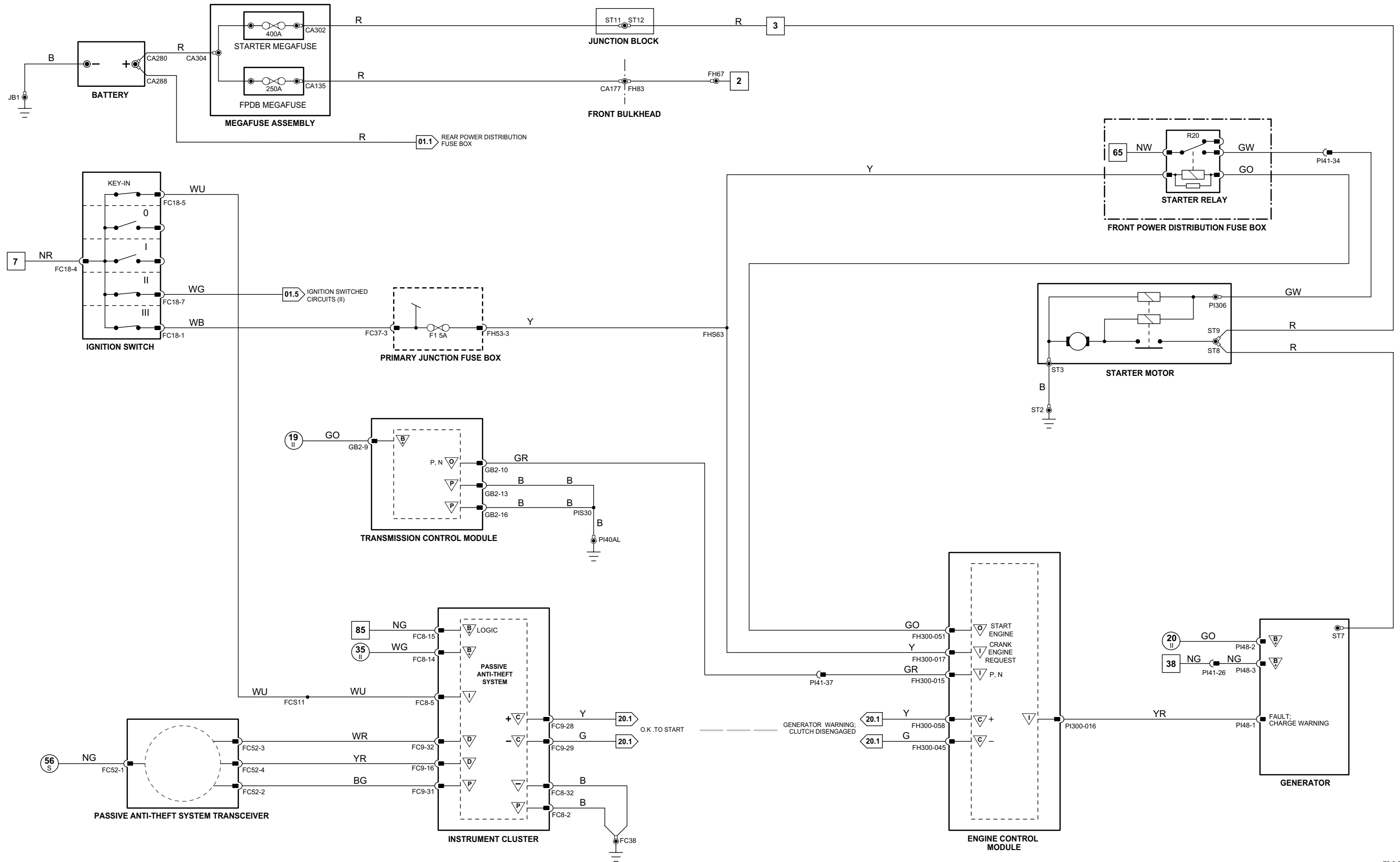

1 → 3 Fig. 01.1	4 → 76 Fig. 01.2	77 → 92 Fig. 01.3	1 → 14 Fig. 01.4	15 → 45 Fig. 01.5	46 → 80 Fig. 01.6	81 → 118 Fig. 01.7	Input Output	Battery Voltage Power Ground	Sensor/Signal Supply V Sensor/Signal Ground	CAN SCP	D2B Network Serial and Encoded Data
--------------------	---------------------	----------------------	---------------------	----------------------	----------------------	-----------------------	-----------------	---------------------------------	--	------------	--

VARIANT: V8 Vehicles
 VIN RANGE: All
 DATE OF ISSUE: April 2006

Powertrain Control Module

	Pin	Description and Characteristic
C	C98-A3	CAN -
C	C98-A4	CAN +
O	C98-H1	GENERATOR COMMAND LINE: PWM
I	C99-F2	GENERATOR MONITOR LINE
O	FH13-B1	STARTER RELAY DRIVE: TO ACTIVATE, ECM SWITCHES CIRCUIT TO GROUND
I	FH13-D4	AUTOMATIC - PARK / NEUTRAL SIGNAL: B+ WHEN ACTIVATED
I	FH13-F3	ENGINE CRANK: B+

Instrument Cluster

	Pin	Description and Characteristic
PG	FC8-2	POWER GROUND: GROUND
I	FC8-5	KEY-IN AUDIBLE WARNING: B+ WHEN KEY IN
B+	FC8-14	IGNITION SWITCHED POWER SUPPLY (II): B+
B+	FC8-15	BATTERY POWER SUPPLY (LOGIC): B+
SG	FC8-32	SIGNAL GROUND: GROUND

D	FC9-16	PATS TRANSCEIVER: ENCODED COMMUNICATION
C	FC9-28	CAN +
C	FC9-29	CAN -
I	FC9-31	PATS GROUND: GROUND
D	FC9-32	PATS TRANSCEIVER: ENCODED COMMUNICATION

Transmission Control Module

	Pin	Description and Characteristic
B+	GB2-9	IGNITION SWITCHED POWER SUPPLY: B+
O	GB2-10	PARK / NEUTRAL SIGNAL: GROUND WHEN ACTIVATED
PG	GB2-13	POWER GROUND: GROUND
PG	GB2-16	POWER GROUND: GROUND

Fig. 02.3

COMPONENTS

Component	Connector(s)	Connector Description	Location
BATTERY	—	—	LUGGAGE COMPARTMENT
FPDB MEGAFUSE	—	—	LUGGAGE COMPARTMENT, RH SIDE
FRONT POWER DISTRIBUTION FUSE BOX	—	—	ENGINE COMPARTMENT, RH SIDE
GENERATOR	C73	3-WAY / BLACK	ENGINE, RH SIDE, FRONT
	ST7	EYELET	
GLOW PLUG MIDIFUSE	—	—	
IGNITION SWITCH	FC18	7-WAY / BLACK	STEERING COLUMN COWLING
INSTRUMENT CLUSTER	FC8	32-WAY / BLACK	INSTRUMENT PANEL
	FC9	32-WAY / BLACK	
PASSIVE ANTI-THEFT SYSTEM TRANSCEIVER	FC52	4-WAY / GREEN	STEERING COLUMN, IGNITION SWITCH
POWERTRAIN CONTROL MODULE	C98	48-WAY / BROWN	FRONT BULKHEAD, PASSENGER SIDE
	C99	48-WAY / GREY	
	FH13	48-WAY / BLACK	
PRIMARY JUNCTION FUSE BOX	CA2	26-WAY / BLACK	RH 'A' POST
	CA56	8-WAY / BLACK	
	FC37	26-WAY / BLACK	
	FH7	6-WAY / BLACK	
	FH53	10-WAY / BLACK	
STARTER MEGAFUSE	—	—	LUGGAGE COMPARTMENT, RH SIDE
STARTER MOTOR	—	—	ENGINE BLOCK, RH SIDE
STARTER RELAY	—	—	FRONT POWER DISTRIBUTION FUSE BOX - R20
TRANSMISSION CONTROL MODULE	GB2	16-WAY / BLACK	TRANSMISSION CONTROL VALVE ASSEMBLY

HARNESS IN-LINE CONNECTORS

Connector	Connector Description / Location	Location
GB1	16-WAY / GREY / ENGINE HARNESS TO TRANSMISSION HARNESS	ADJACENT TO TRANSMISSION BELL HOUSING
PI41	42-WAY / BLACK / ENGINE HARNESS TO VEHICLE HARNESSES	ENGINE COMPARTMENT, BULKHEAD, PASSENGER SIDE

GROUNDS

Ground	Location
FC38	UNDER CENTER OF INSTRUMENT PANEL, ON TRANSMISSION TUNNEL
FH4 (LHD)	ENGINE COMPARTMENT, BEHIND RH WHEEL ARCH LINER
FH4 (RHD)	ENGINE COMPARTMENT, BEHIND LH WHEEL ARCH LINER
JB1	LUGGAGE COMPARTMENT, BATTERY GROUND
ST2	ENGINE COMPARTMENT, BEHIND LH WHEEL ARCH LINER

FOR CONTROL MODULE PIN-OUT INFORMATION, UNFOLD PAGE TO LEFT.

The following abbreviations are used to represent values for Control Module Pin-Out data

I	Input	PG	Power Ground	C	CAN Network	D	Serial and Encoded Data
O	Output	SS	Sensor / Signal Supply V	S	SCP Network	V	Voltage (DC)
B+	Battery Voltage	SG	Sensor / Signal Ground	D2	D2B Network	PWM	Pulse Width Modulated

CAUTION: The information on this data page is furnished to aid the user in understanding circuit operation. THIS INFORMATION SHOULD BE USED FOR REFERENCE ONLY.

NOTE: The values listed are approximately those that can be expected at the control module connector pins with all circuit connections made and all components connected and fitted.

Refer to the front of this book for detailed information and illustrations regarding the location and identification of harnesses, relays, fuses, grounds, control modules and control module pins.

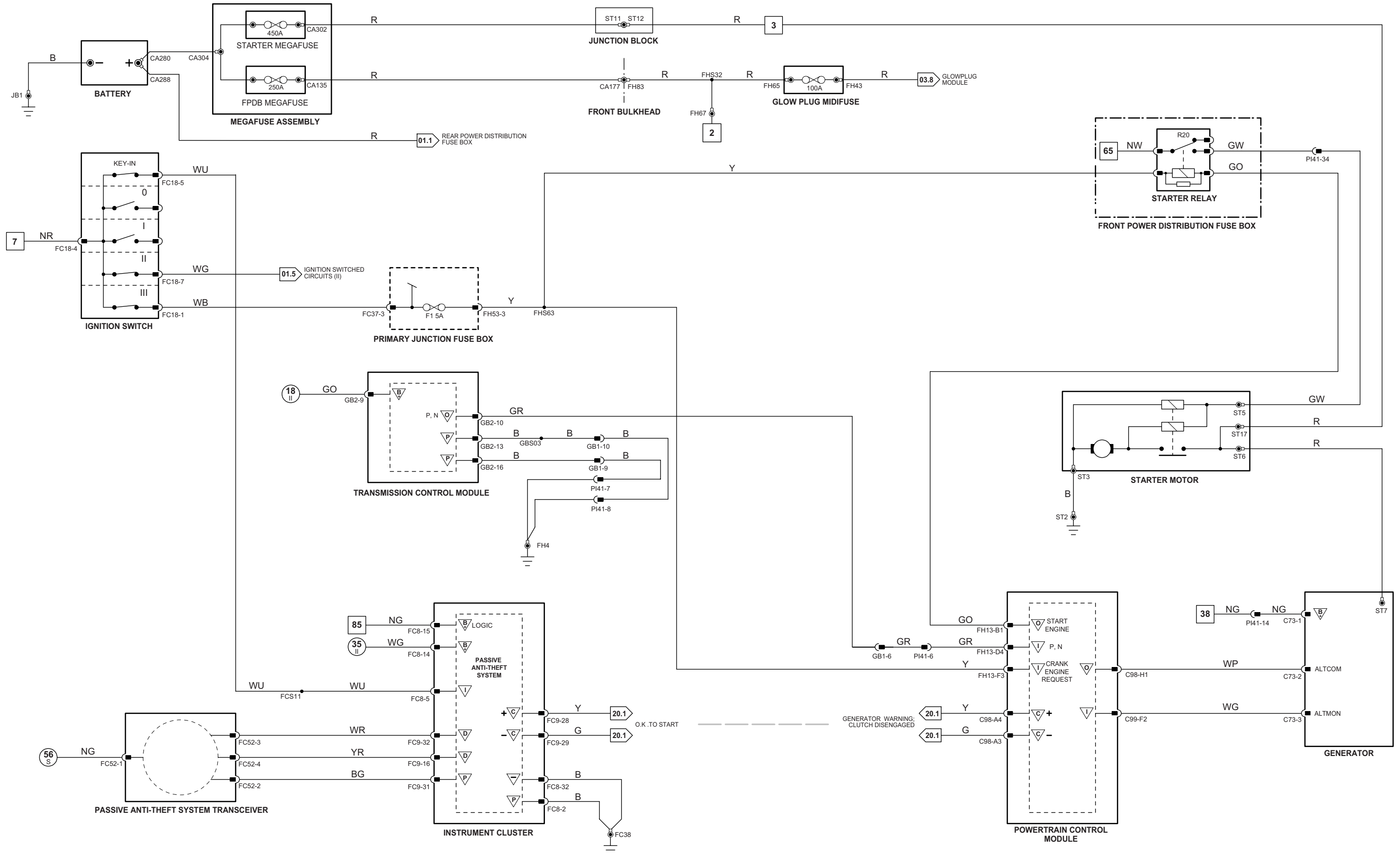

VARIANT: Diesel 2.7V6
 VIN RANGE: All
 DATE OF ISSUE: April 2006

Engine Control Module

	Pin	Description and Characteristic
SG	FH300-01	SMALL SIGNAL GROUND 1: GROUND
PG	FH300-02	POWER GROUND 1: GROUND
PG	FH300-03	POWER GROUND 2: GROUND
B+	FH300-04	EMS SWITCHED POWER SUPPLY 1: B+
PG	FH300-05	POWER GROUND 3: GROUND
B+	FH300-06	EMS SWITCHED POWER SUPPLY 2: B+
SG	FH300-07	SENSOR GROUND 1: GROUND
SG	FH300-08	SENSOR GROUND 2: GROUND
I	FH300-15	AUTOMATIC - PARK / NEUTRAL SIGNAL: B+ WHEN ACTIVATED MANUAL, ROW - PARK / NEUTRAL SIGNAL: B+ WHEN IGNITION CRANK (III) EMS CONTROL RELAY DRIVE: TO ACTIVATE, ECM SWITCHES CIRCUIT TO GROUND
O	FH300-16	ENGINE CRANK: B+
I	FH300-17	SENSOR POWER SUPPLY 2: NOMINAL 5 V
SS	FH300-19	ACCELERATOR PEDAL POSITION SENSOR 1 SIGNAL: FOOT OFF = 0.75 V; FULLY DEPRESSED = 3.40 V (AUTO) 3.20 V (MAN)
I	FH300-24	IGNITION ON: B+
I	FH300-30	SENSOR POWER SUPPLY 1: NOMINAL 5 V
SS	FH300-32	ACCELERATOR PEDAL POSITION SENSOR 2 SIGNAL: FOOT OFF = 3.38 V; FULLY DEPRESSED = 2.05 V (AUTO) 2.14 V (MAN)
I	FH300-38	BRAKE ON / OFF SWITCH: NORMALLY OPEN / B+ WHEN ACTIVATED
I	FH300-41	INERTIA SWITCH: NORMALLY CLOSED / OPEN CIRCUIT WHEN ACTIVATED
I	FH300-42	CAM -
C	FH300-45	STARTER RELAY DRIVE: TO ACTIVATE, ECM SWITCHES CIRCUIT TO GROUND
O	FH300-51	BATTERY POWER SUPPLY: B+
B+	FH300-54	CAM +
C	FH300-58	GENERATOR FIELD RETURN SIGNAL: VARIABLE VOLTAGE BY GENERATOR OPERATING CONDITION
I	PI300-03	CRANKSHAFT SENSOR SIGNAL GROUND: GROUND
SG	PI300-06	BANK 1 CAMSHAFT SENSOR GROUND: GROUND
SG	PI300-07	BANK 2 CAMSHAFT SENSOR GROUND: GROUND
SG	PI300-08	SENSOR GROUND: GROUND
SG	PI300-10	THROTTLE POSITION SENSOR GROUND: GROUND
SG	PI300-11	SENSOR GROUND: GROUND
SG	PI300-12	SENSOR GROUND: GROUND
SG	PI300-15	SENSOR GROUND: GROUND
I	PI300-16	GENERATOR FAULT: CHARGE WARNING
SG	PI300-18	MASS AIR FLOW SENSOR GROUND: GROUND
SG	PI300-19	BANK 1 KNOCK SENSOR GROUND: GROUND
SG	PI300-20	BANK 2 KNOCK SENSOR GROUND: GROUND
SG	PI300-22	HO2 SENSORS 1/2 SHIELD: GROUND
I	PI300-23	ENGINE OIL TEMPERATURE SENSOR SIGNAL, NOMINAL 0 - 5 V: NTC SENSOR - VOLTAGE DECREASES AS TEMPERATURE INCREASES
SS	PI300-24	SENSOR POWER SUPPLY: NOMINAL 5V
I	PI300-26	HO2 SENSOR 2/1 SIGNAL: VARIABLE CURRENT
I	PI300-27	HO2 SENSOR 2/1 SIGNAL: CONSTANT CURRENT
I	PI300-28	HO2 SENSOR 1/1 SIGNAL: VARIABLE CURRENT
I	PI300-29	HO2 SENSOR 1/1 SIGNAL: CONSTANT CURRENT
I	PI300-30	CRANKSHAFT SENSOR SIGNAL: PULSED SIGNAL, 70 PULSES PER ENGINE CYCLE
I	PI300-33	BANK 2 CAMSHAFT SENSOR SIGNAL: PULSED SIGNAL, 4 PULSES PER ENGINE CYCLE
I	PI300-34	BANK 1 CAMSHAFT SENSOR SIGNAL: PULSED SIGNAL, 4 PULSES PER ENGINE CYCLE
I	PI300-40	HO2 SENSOR 1/2 SIGNAL, NOMINAL 1 V SWING: 0.1 - 0.9 V SWING
I	PI300-41	HO2 SENSOR 2/2 SIGNAL, NOMINAL 1 V SWING: 0.1 - 0.9 V SWING
I	PI300-42	BANK 1 KNOCK SENSOR SIGNAL: VARIABLE VOLTAGE DEPENDENT ON ENGINE VIBRATION
I	PI300-43	BANK 2 KNOCK SENSOR SIGNAL: VARIABLE VOLTAGE DEPENDENT ON ENGINE VIBRATION
SG	PI300-45	HO2 SENSORS 2/2 SHIELD: GROUND
I	PI300-46	ENGINE FUEL TEMPERATURE SENSOR SIGNAL, NOMINAL 0 - 5 V: NTC SENSOR - VOLTAGE DECREASES AS TEMPERATURE INCREASES
SS	PI300-47	SENSOR POWER SUPPLY: NOMINAL 5V
I	PI300-65	THROTTLE POSITION SENSOR 1 SIGNAL: IDLE = 0.60 V; FULL THROTTLE = 4.30 V
I	PI300-66	INTAKE AIR TEMPERATURE SENSOR SIGNAL, NOMINAL 0 - 5 V: NTC SENSOR - VOLTAGE DECREASES AS TEMPERATURE INCREASES
I	PI300-67	THROTTLE POSITION SENSOR 2 SIGNAL: IDLE = 1.48 V; FULL THROTTLE = 4.40 V
I	PI300-68	ENGINE COOLANT TEMPERATURE SENSOR SIGNAL, NOMINAL 0 - 5 V: NTC SENSOR - VOLTAGE DECREASES AS TEMPERATURE INCREASES
I	PI300-69	MAP SENSOR SIGNAL, NOMINAL 0 - 5 V: VOLTAGE INCREASES AS MANIFOLD ABSOLUTE PRESSURE INCREASES
I	PI300-70	MASS AIR FLOW SENSOR SIGNAL: NOMINAL 0 - 5 V BY ENGINE OPERATING CONDITION
I	PI300-71	INJECTION PRESSURE SENSOR SIGNAL, NOMINAL 0 - 5 V: POTENTIOMETER - VOLTAGE INCREASES AS PRESSURE INCREASES
SS	PI300-72	THROTTLE POSITION SENSOR POWER SUPPLY: NOMINAL 5 V
O	PI300-74	THROTTLE MOTOR GROUND: GROUND
O	PI300-75	THROTTLE MOTOR DRIVE: B+ TO ACTIVATE MOTOR
O	PI300-76	HO2 SENSOR HEATER CONTROL - 1/1: PWM, 1 CYCLE PER 128 mS, VARIABLE DUTY CYCLE
O	PI300-77	HO2 SENSOR HEATER CONTROL - 2/1: PWM, 1 CYCLE PER 128 mS, VARIABLE DUTY CYCLE
O	PI300-84	INTAKE MANIFOLD TUNING VALVE SOLENOID DRIVE - 1 / TOP: GROUND WHEN ACTIVATED
O	PI300-86	BANK 1 VVT SOLENOID VALVE: PWM, 300 Hz, POSITIVE DUTY CYCLE RANGE 0% - 100%
O	PI300-87	BANK 2 VVT SOLENOID VALVE: PWM, 300 Hz, POSITIVE DUTY CYCLE RANGE 0% - 100%
O	PI300-88	HO2 SENSOR HEATER CONTROL - 1/2: PWM, 1 CYCLE PER 256 mS, POSITIVE DUTY CYCLE RANGE 0 mS = 0%, 77 mS = 30%, 256 mS = 100%
O	PI300-89	HO2 SENSOR HEATER CONTROL - 2/2: PWM, 1 CYCLE PER 256 mS, POSITIVE DUTY CYCLE RANGE 0 mS = 0%, 77 mS = 30%, 256 mS = 100%
O	PI300-90	INTAKE MANIFOLD TUNING VALVE SOLENOID DRIVE - 2 / BOTTOM: GROUND WHEN ACTIVATED
O	PI300-92	EVAP CANISTER PURGE VALVE DRIVE: PWM, 10 Hz, POSITIVE DUTY CYCLE RANGE 7% - 100%
O	PI300-96	GENERATOR CONTROL: VARIABLE VOLTAGE

The following abbreviations are used to represent values for Control Module Pin-Out data

I	Input	PG	Power Ground	C	CAN Network	D	Serial and Encoded Data
O	Output	SS	Sensor / Signal Supply V	S	SCP Network	V	Voltage (DC)
B+	Battery Voltage	SG	Sensor / Signal Ground	D2	D2B Network	PWM	Pulse Width Modulated

CAUTION: The information on this data page is furnished to aid the user in understanding circuit operation. THIS INFORMATION SHOULD BE USED FOR REFERENCE ONLY.

NOTE: The values listed are approximately those that can be expected at the control module connector pins with all circuit connections made and all components connected and fitted.

Fig. 03.1

COMPONENTS

Component	Connector(s)	Connector Description	Location
APP SENSOR	CA88	6-WAY / BLACK	TOP OF ACCELERATOR PEDAL
BRAKE ON / OFF SWITCH	CA37	2-WAY / GREEN	TOP OF BRAKE PEDAL
CKP SENSOR	PI21	2-WAY / BLACK	ENGINE TIMING COVER, CRANKSHAFT PULLEY
CMP SENSOR 1	PI23	2-WAY / BLACK	BANK 1 (RH) CAMSHAFT COVER, FRONT
CMP SENSOR 2	PI22	2-WAY / BLACK	BANK 2 (LH) CAMSHAFT COVER, FRONT
ECT SENSOR	PI25	2-WAY / BLACK	ENGINE VEE, COOLANT OUTLET CASTING
EFT SENSOR	IL9	2-WAY / BLACK	FUEL RAIL, FRONT
ENGINE CONTROL MODULE	FH300	58-WAY / BLACK	FRONT BULKHEAD, PASSENGER SIDE
	PI300	96-WAY / BLAVK	FRONT BULKHEAD, PASSENGER SIDE
EOT SENSOR	PI24	2-WAY / BLACK	ADJACENT TO OIL FILTER
EVAP CANISTER PURGE VALVE	PI304	2-WAY / BLACK	ENGINE COMPARTMENT, LH SIDE, ADJACENT TO SUSPENSION TURRET
HO2 SENSOR DOWNSTREAM 1/2	PI11	4-WAY / BLACK	RH EXHAUST, CATALYST CENTER
HO2 SENSOR DOWNSTREAM 2/2	PI13	4-WAY / BLACK	LH EXHAUST, CATALYST CENTER
HO2 SENSOR UPSTREAM 1/1	PI10	4-WAY / BLACK	RH EXHAUST, TOP OF CATALYST
HO2 SENSOR UPSTREAM 2/1	PI12	4-WAY / BLACK	LH EXHAUST, TOP OF CATALYST
IMT SOLENOID VALVE 1	PI30	2-WAY / BLACK	INTAKE MANIFOLD, REAR
IMT SOLENOID VALVE 2	PI31	2-WAY / BLACK	INTAKE MANIFOLD, REAR
IP SENSOR	IL12	3-WAY / BLACK	FUEL RAIL, REAR
KNOCK SENSOR 1	PI43	2-WAY / BLACK	ENGINE VEE, TOWARD FRONT, BANK 2 (FRONT SENSOR)
KNOCK SENSOR 2	PI44	2-WAY / BLACK	ENGINE BLOCK, REAR, BANK 1 (REAR SENSOR)
MAF SENSOR	PI14	5-WAY / BLACK	ENGINE AIR INTAKE, ADJACENT TO AIR CLEANER
MAP SENSOR	PI29	4-WAY / BLACK	INTAKE MANIFOLD, UPPER REAR
THROTTLE BODY	PI26	—	ENGINE AIR INTAKE, FRONT
THROTTLE MOTOR	—	—	THROTTLE BODY
TP SENSOR	—	—	THROTTLE BODY
VVT SOLENOID VALVE 1	PI16	2-WAY / BLACK	RH CYLINDER HEAD, FRONT
VVT SOLENOID VALVE 2	PI17	2-WAY / BLACK	LH CYLINDER HEAD, FRONT

HARNESS IN-LINE CONNECTORS

Connector	Connector Description / Location	Location
FC12	14-WAY / GREY / FASCIA HARNESS TO FRONT HARNESS	BEHIND INSTRUMENT PANEL, PASSENGER SIDE
FC26	16-WAY / BLUE / CABIN HARNESS TO FASCIA HARNESS	BEHIND INSTRUMENT PANEL, DRIVER SIDE
FH1	22-WAY / DARK GREY / CABIN HARNESS TO FRONT HARNESS	RH 'A' POST, LOWER
IL10	12-WAY / BLACK / ENGINE HARNESS TO FUEL INJECTOR LINK	REAR OF ENGINE

GROUNDS

Ground	Location
FH4 (LHD)	ENGINE COMPARTMENT, BEHIND RH WHEEL ARCH LINER
FH4 (RHD)	ENGINE COMPARTMENT, BEHIND LH WHEEL ARCH LINER

FOR CONTROL MODULE PIN-OUT INFORMATION, UNFOLD PAGE TO LEFT.

Refer to the front of this book for detailed information and illustrations regarding the location and identification of harnesses, relays, fuses, grounds, control modules and control module pins.

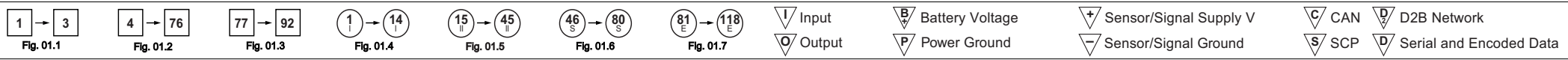
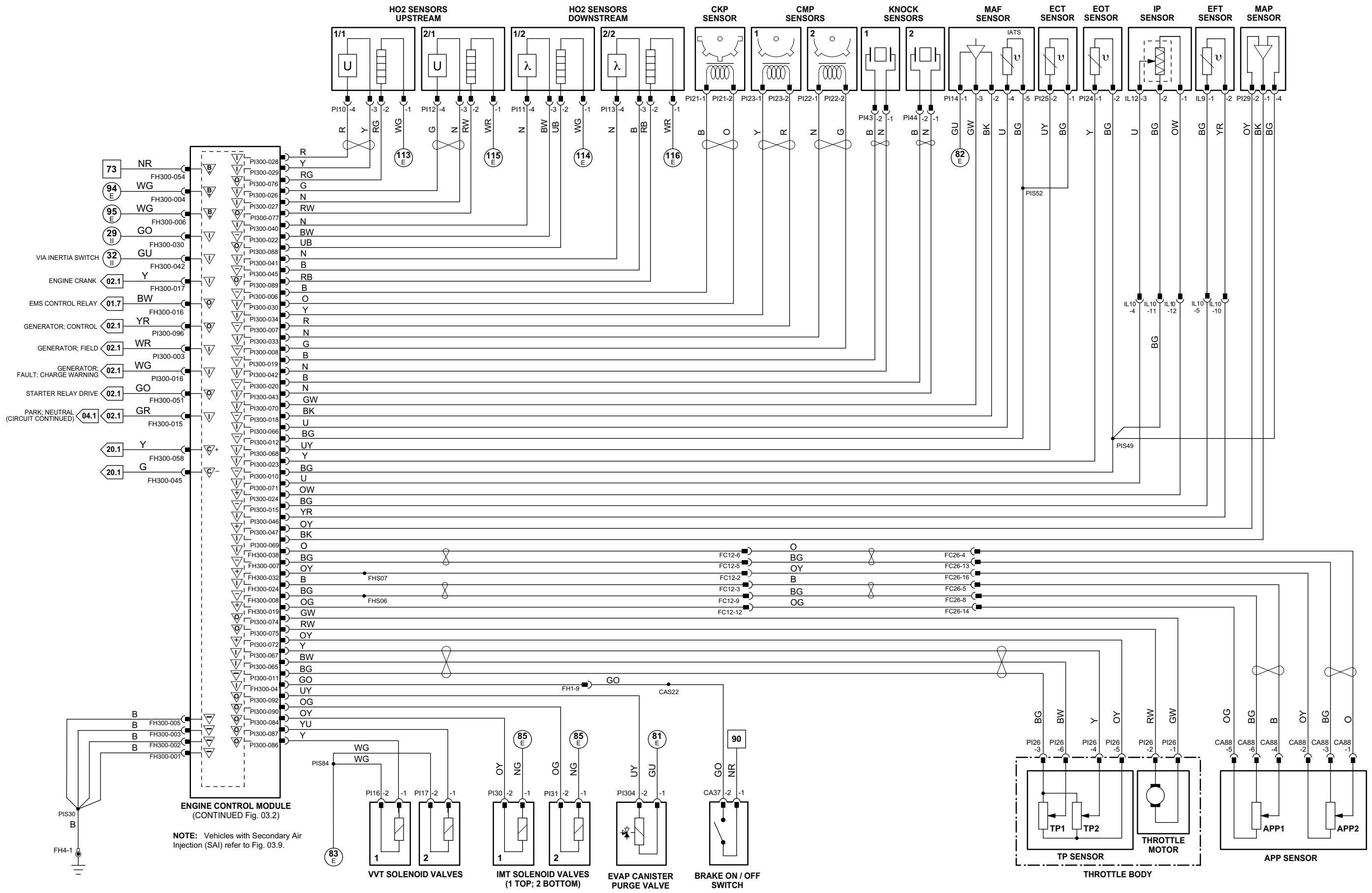

VARIANT: V6 Vehicles
 VIN RANGE: All
 DATE OF ISSUE: April 2006

Engine Control Module

	Pin	Description and Characteristic
SG	FH300-08	SENSOR GROUND 1: GROUND
I	FH300-12	AIR CONDITIONING PRESSURE SENSOR SIGNAL, NOMINAL 0 – 5 V; TRANSDUCER – VOLTAGE INCREASES AS PRESSURE INCREASES
O	FH300-20	FUEL PUMP DRIVE SIGNAL (TO REM): PWM, 150 Hz, NORMAL POSITIVE DUTY CYCLE RANGE = 4% – 51%
O	FH300-23	LEAK DETECTION HEATER CONTROL
SS	FH300-32	SENSOR POWER SUPPLY 1: NOMINAL 5 V
O	FH300-33	LEAK DETECTION PUMP CONTROL
I	FH300-35	SPEED CONTROL SWITCHES SIGNAL GROUND: GROUND
SS	FH300-36	SPEED CONTROL SWITCH REQUEST: STEPPED RESISTANCE
I	FH300-40	BRAKE CANCEL SWITCH: NORMALLY CLOSED / GROUND WHEN ACTIVATED
I	FH300-43	CLUTCH CANCEL SWITCH: NORMALLY CLOSED / GROUND WHEN ACTIVATED
O	FH300-48	LEAK DETECTION VALVE CONTROL
O	FH300-49	COOLING FAN MODULE CONTROL: PWM, 140 Hz, POSITIVE DUTY CYCLE RANGE 7% – 95%
O	FH300-53	AIR CONDITIONING COMPRESSOR CLUTCH RELAY DRIVE: TO ACTIVATE, ECM SWITCHES CIRCUIT TO GROUND
O	P1300-56	IGNITION COIL ACTIVATE – CYLINDER 6: TO ACTIVATE, ECM SWITCHES CIRCUIT TO GROUND
O	P1300-57	IGNITION COIL ACTIVATE – CYLINDER 5: TO ACTIVATE, ECM SWITCHES CIRCUIT TO GROUND
O	P1300-58	IGNITION COIL ACTIVATE – CYLINDER 4: TO ACTIVATE, ECM SWITCHES CIRCUIT TO GROUND
O	P1300-59	IGNITION COIL ACTIVATE – CYLINDER 3: TO ACTIVATE, ECM SWITCHES CIRCUIT TO GROUND
O	P1300-60	IGNITION COIL ACTIVATE – CYLINDER 2: TO ACTIVATE, ECM SWITCHES CIRCUIT TO GROUND
O	P1300-61	IGNITION COIL ACTIVATE – CYLINDER 1: TO ACTIVATE, ECM SWITCHES CIRCUIT TO GROUND
I	P1300-62	IGNITION MONITOR BANK 1: PULSED SIGNAL, 3 PULSES PER ENGINE CYCLE
I	P1300-64	IGNITION MONITOR BANK 2: PULSED SIGNAL, 3 PULSES PER ENGINE CYCLE
O	P1300-78	FUEL INJECTOR DRIVE – CYLINDER 1: TO ACTIVATE, ECM SWITCHES CIRCUIT TO GROUND
O	P1300-79	FUEL INJECTOR DRIVE – CYLINDER 2: TO ACTIVATE, ECM SWITCHES CIRCUIT TO GROUND
O	P1300-80	FUEL INJECTOR DRIVE – CYLINDER 3: TO ACTIVATE, ECM SWITCHES CIRCUIT TO GROUND
O	P1300-81	FUEL INJECTOR DRIVE – CYLINDER 4: TO ACTIVATE, ECM SWITCHES CIRCUIT TO GROUND
O	P1300-82	FUEL INJECTOR DRIVE – CYLINDER 5: TO ACTIVATE, ECM SWITCHES CIRCUIT TO GROUND
O	P1300-83	FUEL INJECTOR DRIVE – CYLINDER 6: TO ACTIVATE, ECM SWITCHES CIRCUIT TO GROUND

Rear Electronic Module

	Pin	Description and Characteristic
B+	CA100-8	IGNITION SWITCHED POWER SUPPLY (II): B+
B+	CA101-1	FUEL PUMP POWER SUPPLY: B+ WHEN FUEL PUMP RELAY IS ACTIVATED
SG	CA101-2	LOGIC GROUND / FUEL PUMP DRIVE SHIELD: GROUND
B+	CA101-3	BATTERY POWER SUPPLY: B+
O	CA101-11	FUEL PUMP SUPPLY VOLTAGE: B+
O	CA101-12	FUEL PUMP ACTIVATE: GROUND (PWM)
S	CA102-1	SCP +
S	CA102-2	SCP –
I	CA103-19	FUEL PUMP DRIVE SIGNAL: PWM, 150 Hz, NORMAL POSITIVE DUTY CYCLE RANGE = 4% – 51%

Fig. 03.2

COMPONENTS

Component	Connector(s)	Connector Description	Location
AIR CONDITIONING COMPRESSOR CLUTCH	PI49	2-WAY / BLACK	LOWER LH SIDE OF ENGINE
AIR CONDITIONING COMPRESSOR CLUTCH RELAY	—	—	FRONT POWER DISTRIBUTION FUSE BOX – R8
AIR CONDITIONING PRESSURE SENSOR	FH110	4-WAY / BLACK	ENGINE COMPARTMENT, LH SIDE, HIGH PRESSURE REFRIGERANT LINE, BETWEEN COMPRESSOR AND CONDENSER
BRAKE CANCEL SWITCH	CA36	2-WAY / GREY	TOP OF BRAKE PEDAL
CLUTCH CANCEL SWITCH	CA285 (LHD)	2-WAY / BLACK	TOP OF CLUTCH PEDAL (TOP SWITCH)
COOLING FAN MODULE	CA291 (RHD)	5-WAY / BLACK	ENGINE COMPARTMENT, RH FRONT, REARWARD OF RADIATOR
ENGINE CONTROL MODULE	FH108	2-WAY / BLACK	
	FH109	2-WAY / BLACK	
	P1300	96-WAY / BLACK	FRONT BULKHEAD, PASSENGER SIDE
	FH300	58-WAY / BLACK	FRONT BULKHEAD, PASSENGER SIDE
FRONT POWER DISTRIBUTION FUSE BOX	—	—	ENGINE COMPARTMENT, RH SIDE
FUEL INJECTOR 1	IL3	2-WAY / BLACK	FUEL RAIL / INTAKE MANIFOLD
FUEL INJECTOR 2	IL6	2-WAY / BLACK	FUEL RAIL / INTAKE MANIFOLD
FUEL INJECTOR 3	IL4	2-WAY / BLACK	FUEL RAIL / INTAKE MANIFOLD
FUEL INJECTOR 4	IL7	2-WAY / BLACK	FUEL RAIL / INTAKE MANIFOLD
FUEL INJECTOR 5	IL5	2-WAY / BLACK	FUEL RAIL / INTAKE MANIFOLD
FUEL INJECTOR 6	IL8	2-WAY / BLACK	FUEL RAIL / INTAKE MANIFOLD
FUEL PUMP	FP16	6-WAY / BLACK	FUEL TANK, RH SIDE
FUEL PUMP RELAY	—	—	REAR POWER DISTRIBUTION FUSE BOX – R15
IGNITION CAPACITOR	PI54	2-WAY / BLACK	LH CYLINDER HEAD, REAR
IGNITION MODULE AND COIL 1	PI2	4-WAY / BLACK	RH CYLINDER HEAD
IGNITION MODULE AND COIL 2	PI6	4-WAY / BLACK	LH CYLINDER HEAD
IGNITION MODULE AND COIL 3	PI3	4-WAY / BLACK	RH CYLINDER HEAD
IGNITION MODULE AND COIL 4	PI7	4-WAY / BLACK	LH CYLINDER HEAD
IGNITION MODULE AND COIL 5	PI4	4-WAY / BLACK	RH CYLINDER HEAD
IGNITION MODULE AND COIL 6	PI8	4-WAY / BLACK	LH CYLINDER HEAD
LEAK DETECTION UNIT	CA401	4-WAY / BLACK	ABOVE FUEL TANK
REAR ELECTRONIC MODULE	CA63	17-WAY / BLACK	LUGGAGE COMPARTMENT, RH REAR
	CA100	12-WAY / BLACK	
	CA101	20-WAY / BLACK	
	CA102	22-WAY / BLACK	
	CA103	26-WAY / NATURAL	
REAR POWER DISTRIBUTION FUSE BOX	—	—	LUGGAGE COMPARTMENT
STEERING WHEEL SPEED CONTROL SWITCHES	SQ2	6-WAY / BLACK	STEERING WHEEL

HARNES IN-LINE CONNECTORS

Connector	Connector Description / Location	Location
FC10	14-WAY / GREEN / FASCIA HARNESS TO FRONT HARNESS	BEHIND INSTRUMENT PANEL, RH SIDE
FC117	10-WAY / BLACK / STEERING WHEEL CASSETTE	STEERING COLUMN
FH1	22-WAY / DARK GREY / CABIN HARNESS TO FRONT HARNESS	RH 'A' POST LOWER
FH3	16-WAY / BLUE / CABIN HARNESS TO FRONT HARNESS	LH 'A' POST
FP4	8-WAY / GREY / FUEL TANK HARNESS TO VEHICLE HARNESS	BIW ABOVE FUEL TANK, RH SIDE
IL10	12-WAY / BLACK / ENGINE HARNESS TO FUEL INJECTOR LINK	REAR OF ENGINE
PI41	42-WAY / BLACK / ENGINE HARNESS TO VEHICLE HARNESSES	ENGINE COMPARTMENT, BULKHEAD, PASSENGER SIDE

GROUNDS

Ground	Location
CA30	LOWER 'A' POST, LH SIDE
CA50	LOWER 'A' POST, RH SIDE
CA156	LUGGAGE COMPARTMENT, RH SIDE
FH22	ENGINE COMPARTMENT, BEHIND LH HEADLAMP
FH42	ENGINE COMPARTMENT, BEHIND RH HEADLAMP
FH95	ENGINE COMPARTMENT, BEHIND LH HEADLAMP (RADIATOR FAN GROUND)
PI51	ENGINE COMPARTMENT, ENGINE BLOCK

FOR CONTROL MODULE PIN-OUT INFORMATION, UNFOLD PAGE TO LEFT.

The following abbreviations are used to represent values for Control Module Pin-Out data

I	Input	PG	Power Ground	C	CAN Network	D	Serial and Encoded Data
O	Output	SS	Sensor / Signal Supply V	S	SCP Network	V	Voltage (DC)
B+	Battery Voltage	SG	Sensor / Signal Ground	D2	D2B Network	PWM	Pulse Width Modulated

CAUTION: The information on this data page is furnished to aid the user in understanding circuit operation. THIS INFORMATION SHOULD BE USED FOR REFERENCE ONLY.

NOTE: The values listed are approximately those that can be expected at the control module connector pins with all circuit connections made and all components connected and fitted.

Refer to the front of this book for detailed information and illustrations regarding the location and identification of harnesses, relays, fuses, grounds, control modules and control module pins.

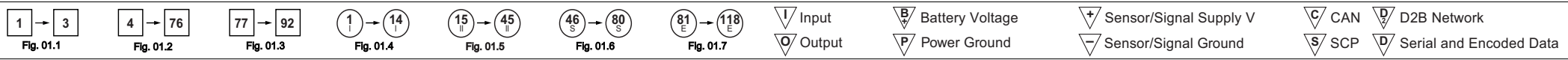
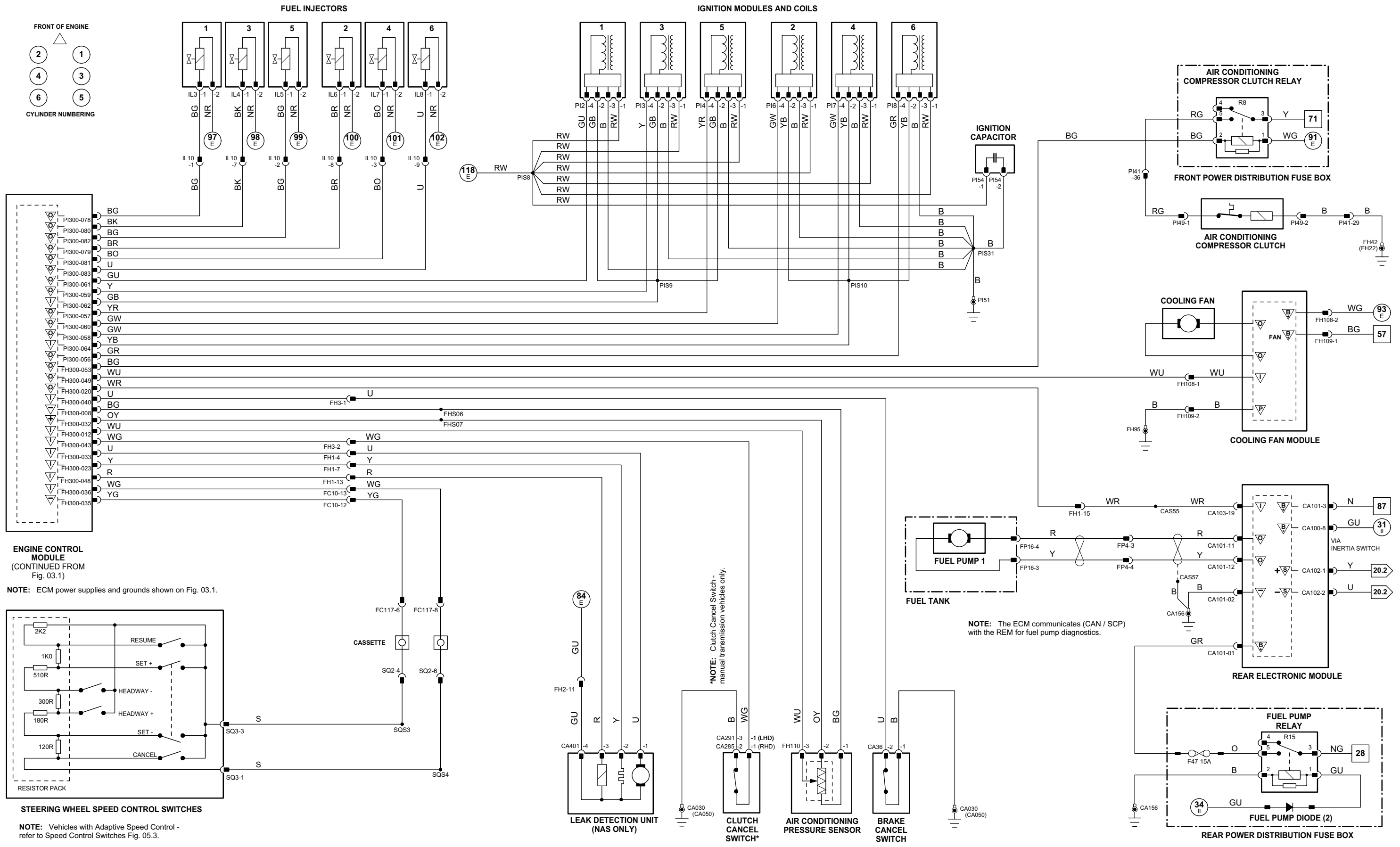

VARIANT: V6 Vehicles
VIN RANGE: All
DATE OF ISSUE: April 2006

Engine Control Module

	Pin	Description and Characteristic
SG	FH300-01	SMALL SIGNAL GROUND 1: GROUND
PG	FH300-02	POWER GROUND 1: GROUND
PG	FH300-03	POWER GROUND 2: GROUND
B+	FH300-04	EMS SWITCHED POWER SUPPLY 1: B+
PG	FH300-05	POWER GROUND 3: GROUND
B+	FH300-06	EMS SWITCHED POWER SUPPLY 2: B+
SG	FH300-07	SENSOR GROUND 1: GROUND
SG	FH300-08	SENSOR GROUND 2: GROUND
I	FH300-15	AUTOMATIC - PARK / NEUTRAL SIGNAL: B+ WHEN ACTIVATED MANUAL, ROW - PARK / NEUTRAL SIGNAL: B+ WHEN IGNITION CRANK (III) EMS CONTROL RELAY DRIVE: TO ACTIVATE, ECM SWITCHES CIRCUIT TO GROUND
O	FH300-16	ENGINE CRANK: B+
I	FH300-17	SENSOR POWER SUPPLY 2: NOMINAL 5 V
SS	FH300-19	ACCELERATOR PEDAL POSITION SENSOR 1 SIGNAL: FOOT OFF = 0.75 V; FULLY DEPRESSED = 3.40 V (AUTO) 3.20 V (MAN)
I	FH300-24	IGNITION ON: B+
I	FH300-30	SENSOR POWER SUPPLY 1: NOMINAL 5 V
SS	FH300-32	ACCELERATOR PEDAL POSITION SENSOR 2 SIGNAL: FOOT OFF = 3.38 V; FULLY DEPRESSED = 2.05 V (AUTO) 2.14 V (MAN)
I	FH300-38	BRAKE ON / OFF SWITCH: NORMALLY OPEN / B+ WHEN ACTIVATED
I	FH300-41	INERTIA SWITCH: NORMALLY CLOSED / OPEN CIRCUIT WHEN ACTIVATED
I	FH300-42	CAM -
C	FH300-45	STARTER RELAY DRIVE: TO ACTIVATE, ECM SWITCHES CIRCUIT TO GROUND
O	FH300-51	BATTERY POWER SUPPLY: B+
B+	FH300-54	CAM +
C	FH300-58	CAM +
SG	PI300-06	CRANKSHAFT SENSOR SIGNAL GROUND: GROUND
SG	PI300-07	BANK 1 CAMSHAFT SENSOR GROUND: GROUND
SG	PI300-08	BANK 2 CAMSHAFT SENSOR GROUND: GROUND
SG	PI300-10	SENSOR GROUND: GROUND
SG	PI300-11	THROTTLE POSITION SENSOR GROUND: GROUND
SG	PI300-12	SENSOR GROUND: GROUND
SG	PI300-15	SENSOR GROUND: GROUND
I	PI300-16	GENERATOR FAULT: CHARGE WARNING
SG	PI300-18	MASS AIR FLOW SENSOR GROUND: GROUND
SG	PI300-19	BANK 1 KNOCK SENSOR GROUND: GROUND
SG	PI300-20	BANK 2 KNOCK SENSOR GROUND: GROUND
SG	PI300-22	HO2 SENSORS 1/2 SHIELD: GROUND
I	PI300-23	ENGINE OIL TEMPERATURE SENSOR SIGNAL, NOMINAL 0 - 5 V: NTC SENSOR - VOLTAGE DECREASES AS TEMPERATURE INCREASES
SS	PI300-24	SENSOR POWER SUPPLY: NOMINAL 5V
I	PI300-26	HO2 SENSOR 2/1 SIGNAL: VARIABLE CURRENT
I	PI300-27	HO2 SENSOR 2/1 SIGNAL: CONSTANT CURRENT
I	PI300-28	HO2 SENSOR 1/1 SIGNAL: VARIABLE CURRENT
I	PI300-29	HO2 SENSOR 1/1 SIGNAL: CONSTANT CURRENT
I	PI300-30	CRANKSHAFT SENSOR SIGNAL: PULSED SIGNAL, 70 PULSES PER ENGINE CYCLE
I	PI300-33	BANK 2 CAMSHAFT SENSOR SIGNAL: PULSED SIGNAL, 4 PULSES PER ENGINE CYCLE
I	PI300-34	BANK 1 CAMSHAFT SENSOR SIGNAL: PULSED SIGNAL, 4 PULSES PER ENGINE CYCLE
I	PI300-40	HO2 SENSOR 1/2 SIGNAL, NOMINAL 1 V SWING: 0.1 - 0.9 V SWING
I	PI300-41	HO2 SENSOR 2/2 SIGNAL, NOMINAL 1 V SWING: 0.1 - 0.9 V SWING
I	PI300-42	BANK 1 KNOCK SENSOR SIGNAL: VARIABLE VOLTAGE DEPENDENT ON ENGINE VIBRATION
I	PI300-43	BANK 2 KNOCK SENSOR SIGNAL: VARIABLE VOLTAGE DEPENDENT ON ENGINE VIBRATION
SG	PI300-45	HO2 SENSORS 2/2 SHIELD: GROUND
I	PI300-46	ENGINE FUEL TEMPERATURE SENSOR SIGNAL, NOMINAL 0 - 5 V: NTC SENSOR - VOLTAGE DECREASES AS TEMPERATURE INCREASES
SS	PI300-47	SENSOR POWER SUPPLY: NOMINAL 5V
O	PI300-50	EGR DRIVE 4: B+; EGR DRIVE 1, 2, 3, 4 ARE OPERATED IN TURN
O	PI300-51	EGR DRIVE 3: B+; EGR DRIVE 1, 2, 3, 4 ARE OPERATED IN TURN
O	PI300-52	EGR DRIVE 2: B+; EGR DRIVE 1, 2, 3, 4 ARE OPERATED IN TURN
O	PI300-53	EGR DRIVE 1: B+; EGR DRIVE 1, 2, 3, 4 ARE OPERATED IN TURN
I	PI300-65	THROTTLE POSITION SENSOR 1 SIGNAL: IDLE = 0.60 V; FULL THROTTLE = 4.30 V
I	PI300-66	INTAKE AIR TEMPERATURE SENSOR SIGNAL, NOMINAL 0 - 5 V: NTC SENSOR - VOLTAGE DECREASES AS TEMPERATURE INCREASES
I	PI300-67	THROTTLE POSITION SENSOR 2 SIGNAL: IDLE = 1.48 V; FULL THROTTLE = 4.40 V
I	PI300-68	ENGINE COOLANT TEMPERATURE SENSOR SIGNAL, NOMINAL 0 - 5 V: NTC SENSOR - VOLTAGE DECREASES AS TEMPERATURE INCREASES
I	PI300-69	MAP SENSOR SIGNAL, NOMINAL 0 - 5 V: VOLTAGE INCREASES AS MANIFOLD ABSOLUTE PRESSURE INCREASES
I	PI300-70	MASS AIR FLOW SENSOR SIGNAL: NOMINAL 0 - 5 V BY ENGINE OPERATING CONDITION
I	PI300-71	INJECTION PRESSURE SENSOR SIGNAL, NOMINAL 0 - 5 V: POTENTIOMETER - VOLTAGE INCREASES AS PRESSURE INCREASES
SS	PI300-72	THROTTLE POSITION SENSOR POWER SUPPLY: NOMINAL 5 V
O	PI300-74	THROTTLE MOTOR GROUND: GROUND
O	PI300-75	THROTTLE MOTOR DRIVE: B+ TO ACTIVATE MOTOR
O	PI300-76	HO2 SENSOR HEATER CONTROL - 1/1: PWM, 1 CYCLE PER 128 mS, VARIABLE DUTY CYCLE
O	PI300-77	HO2 SENSOR HEATER CONTROL - 2/1: PWM, 1 CYCLE PER 128 mS, VARIABLE DUTY CYCLE
O	PI300-86	BANK 1 VVT SOLENOID VALVE: PWM, 300 Hz, POSITIVE DUTY CYCLE RANGE 0% - 100%
O	PI300-87	BANK 2 VVT SOLENOID VALVE: PWM, 300 Hz, POSITIVE DUTY CYCLE RANGE 0% - 100%
O	PI300-88	HO2 SENSOR HEATER CONTROL - 1/2: PWM, 1 CYCLE PER 256 mS, POSITIVE DUTY CYCLE RANGE 0 mS = 0%, 77 mS = 30%, 256 mS = 100%
O	PI300-89	HO2 SENSOR HEATER CONTROL - 2/2: PWM, 1 CYCLE PER 256 mS, POSITIVE DUTY CYCLE RANGE 0 mS = 0%, 77 mS = 30%, 256 mS = 100%
O	PI300-92	EVAP CANISTER PURGE VALVE DRIVE: PWM, 10 Hz, POSITIVE DUTY CYCLE RANGE 7% - 100%

The following abbreviations are used to represent values for Control Module Pin-Out data

I	Input	PG	Power Ground	C	CAN Network	D	Serial and Encoded Data
O	Output	SS	Sensor / Signal Supply V	S	SCP Network	V	Voltage (DC)
B+	Battery Voltage	SG	Sensor / Signal Ground	D2	D2B Network	PWM	Pulse Width Modulated

CAUTION: The information on this data page is furnished to aid the user in understanding circuit operation. THIS INFORMATION SHOULD BE USED FOR REFERENCE ONLY.

NOTE: The values listed are approximately those that can be expected at the control module connector pins with all circuit connections made and all components connected and fitted.

Fig. 03.3

COMPONENTS

Component	Connector(s)	Connector Description	Location
APP SENSOR	CA88	6-WAY / BLACK	TOP OF ACCELERATOR PEDAL
BRAKE ON / OFF SWITCH	CA37	2-WAY / GREEN	TOP OF BRAKE PEDAL
CKP SENSOR	PI21	2-WAY / BLACK	ENGINE TIMING COVER, CRANKSHAFT PULLEY
CMP SENSOR 1	PI23	2-WAY / BLACK	BANK 1 (RH) CAMSHAFT COVER, FRONT
CMP SENSOR 2	PI22	2-WAY / BLACK	BANK 2 (LH) CAMSHAFT COVER, FRONT
ECT SENSOR	PI25	2-WAY / BLACK	ENGINE VEE, COOLANT OUTLET CASTING
EFT SENSOR	IL9	2-WAY / BLACK	FUEL RAIL, FRONT
EGR VALVE	PI15	6-WAY / BLACK	INTAKE MANIFOLD, RH FRONT
ENGINE CONTROL MODULE	FH300	58-WAY / BLACK	FRONT BULKHEAD, PASSENGER SIDE
	PI300	96-WAY / BLAVK	FRONT BULKHEAD, PASSENGER SIDE
EOT SENSOR	PI24	2-WAY / BLACK	ADJACENT TO OIL FILTER
EVAP CANISTER PURGE VALVE	PI304	2-WAY / BLACK	ENGINE COMPARTMENT, LH SIDE, ADJACENT TO SUSPENSION TURRET
HO2 SENSOR DOWNSTREAM 1/2	PI11	4-WAY / BLACK	RH EXHAUST, CATALYST CENTER
HO2 SENSOR DOWNSTREAM 2/2	PI13	4-WAY / BLACK	LH EXHAUST, CATALYST CENTER
HO2 SENSOR UPSTREAM 1/1	PI10	4-WAY / BLACK	RH EXHAUST, TOP OF CATALYST
HO2 SENSOR UPSTREAM 2/1	PI12	4-WAY / BLACK	LH EXHAUST, TOP OF CATALYST
IP SENSOR	PI28	3-WAY / BLACK	FUEL RAIL, REAR
KNOCK SENSOR 1	PI43	2-WAY / BLACK	ENGINE VEE, TOWARD FRONT, BANK 2 (FRONT SENSOR)
KNOCK SENSOR 2	PI44	2-WAY / BLACK	ENGINE BLOCK, REAR, BANK 1 (REAR SENSOR)
MAF SENSOR	PI14	5-WAY / BLACK	ENGINE AIR INTAKE, ADJACENT TO AIR CLEANER
MAP SENSOR	PI29	4-WAY / BLACK	INTAKE MANIFOLD, UPPER REAR
THROTTLE BODY	PI26		ENGINE AIR INTAKE, FRONT
THROTTLE MOTOR	—	—	THROTTLE BODY
TP SENSOR	—	—	THROTTLE BODY
VVT SOLENOID VALVE 1	PI16	2-WAY / BLACK	RH CYLINDER HEAD, FRONT
VVT SOLENOID VALVE 2	PI17	2-WAY / BLACK	LH CYLINDER HEAD, FRONT

HARNESS IN-LINE CONNECTORS

Connector	Connector Description / Location	Location
FC12	14-WAY / GREY / FASCIA HARNESS TO FRONT HARNESS	BEHIND INSTRUMENT PANEL, PASSENGER SIDE
FC26	16-WAY / BLUE / CABIN HARNESS TO FASCIA HARNESS	BEHIND INSTRUMENT PANEL, DRIVER SIDE
FH1	22-WAY / DARK GREY / CABIN HARNESS TO FRONT HARNESS	RH 'A' POST, LOWER

GROUNDS

Ground	Location
FH4 (LHD)	ENGINE COMPARTMENT, BEHIND RH WHEEL ARCH LINER
FH4 (RHD)	ENGINE COMPARTMENT, BEHIND LH WHEEL ARCH LINER

FOR CONTROL MODULE PIN-OUT INFORMATION, UNFOLD PAGE TO LEFT.

Refer to the front of this book for detailed information and illustrations regarding the location and identification of harnesses, relays, fuses, grounds, control modules and control module pins.

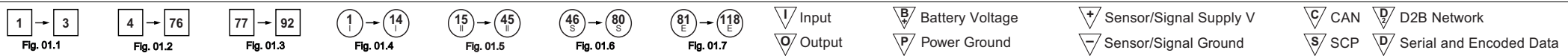
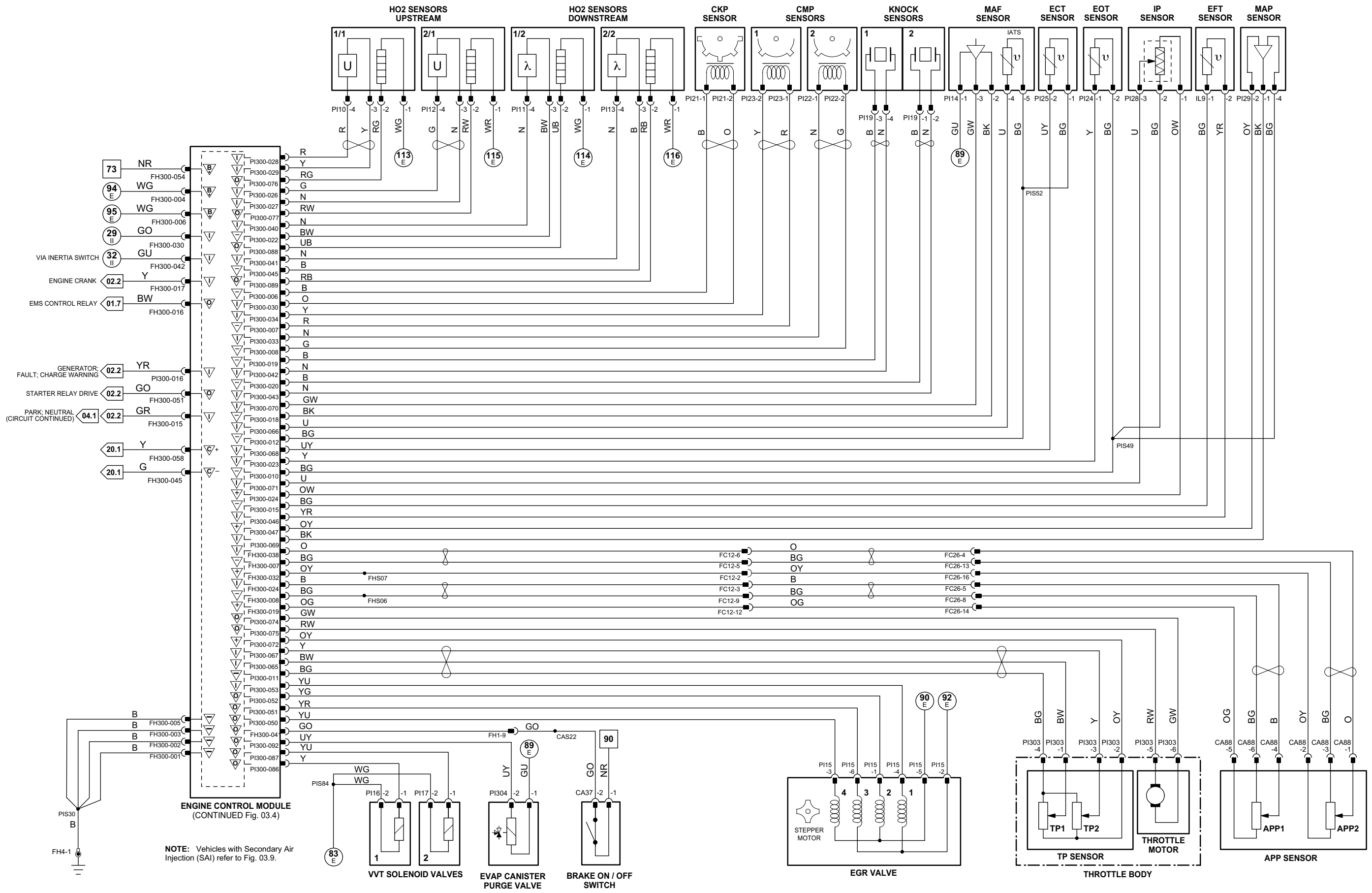

VARIANT: V8 N/A Vehicles
 VIN RANGE: All
 DATE OF ISSUE: April 2006

Fig. 03.4

Engine Control Module

	Pin	Description and Characteristic
SG	FH300-08	SENSOR GROUND 1: GROUND
I	FH300-12	AIR CONDITIONING PRESSURE SENSOR SIGNAL, NOMINAL 0 – 5 V: TRANSDUCER – VOLTAGE INCREASES AS PRESSURE INCREASES
O	FH300-20	FUEL PUMP DRIVE SIGNAL (TO REM): PWM, 150 Hz, NORMAL POSITIVE DUTY CYCLE RANGE = 4% – 51%
O	FH300-23	LEAK DETECTION HEATER CONTROL
SS	FH300-32	SENSOR POWER SUPPLY 1: NOMINAL 5 V
O	FH300-33	LEAK DETECTION PUMP CONTROL
I	FH300-35	SPEED CONTROL SWITCHES SIGNAL GROUND: GROUND
SS	FH300-36	SPEED CONTROL SWITCH REQUEST: STEPPED RESISTANCE
I	FH300-40	BRAKE CANCEL SWITCH: NORMALLY CLOSED / GROUND WHEN ACTIVATED
I	FH300-43	CLUTCH CANCEL SWITCH: NORMALLY CLOSED / GROUND WHEN ACTIVATED
O	FH300-48	LEAK DETECTION VALVE CONTROL
O	FH300-49	COOLING FAN MODULE CONTROL: PWM, 140 Hz, POSITIVE DUTY CYCLE RANGE 7% – 95%
O	FH300-53	AIR CONDITIONING COMPRESSOR CLUTCH RELAY DRIVE: TO ACTIVATE, ECM SWITCHES CIRCUIT TO GROUND
O	P1300-55	IGNITION COIL ACTIVATE – CYLINDER 7: TO ACTIVATE, ECM SWITCHES CIRCUIT TO GROUND
O	P1300-56	IGNITION COIL ACTIVATE – CYLINDER 6: TO ACTIVATE, ECM SWITCHES CIRCUIT TO GROUND
O	P1300-56	IGNITION COIL ACTIVATE – CYLINDER 8: TO ACTIVATE, ECM SWITCHES CIRCUIT TO GROUND
O	P1300-57	IGNITION COIL ACTIVATE – CYLINDER 5: TO ACTIVATE, ECM SWITCHES CIRCUIT TO GROUND
O	P1300-58	IGNITION COIL ACTIVATE – CYLINDER 4: TO ACTIVATE, ECM SWITCHES CIRCUIT TO GROUND
O	P1300-59	IGNITION COIL ACTIVATE – CYLINDER 3: TO ACTIVATE, ECM SWITCHES CIRCUIT TO GROUND
O	P1300-60	IGNITION COIL ACTIVATE – CYLINDER 2: TO ACTIVATE, ECM SWITCHES CIRCUIT TO GROUND
O	P1300-61	IGNITION COIL ACTIVATE – CYLINDER 1: TO ACTIVATE, ECM SWITCHES CIRCUIT TO GROUND
I	P1300-62	IGNITION MONITOR BANK 1: PULSED SIGNAL, 3 PULSES PER ENGINE CYCLE
I	P1300-64	IGNITION MONITOR BANK 2: PULSED SIGNAL, 3 PULSES PER ENGINE CYCLE
O	P1300-78	FUEL INJECTOR DRIVE – CYLINDER 1: TO ACTIVATE, ECM SWITCHES CIRCUIT TO GROUND
O	P1300-79	FUEL INJECTOR DRIVE – CYLINDER 2: TO ACTIVATE, ECM SWITCHES CIRCUIT TO GROUND
O	P1300-80	FUEL INJECTOR DRIVE – CYLINDER 3: TO ACTIVATE, ECM SWITCHES CIRCUIT TO GROUND
O	P1300-81	FUEL INJECTOR DRIVE – CYLINDER 4: TO ACTIVATE, ECM SWITCHES CIRCUIT TO GROUND
O	P1300-82	FUEL INJECTOR DRIVE – CYLINDER 5: TO ACTIVATE, ECM SWITCHES CIRCUIT TO GROUND
O	P1300-83	FUEL INJECTOR DRIVE – CYLINDER 6: TO ACTIVATE, ECM SWITCHES CIRCUIT TO GROUND
O	P1300-84	FUEL INJECTOR DRIVE – CYLINDER 7: TO ACTIVATE, ECM SWITCHES CIRCUIT TO GROUND
O	P1300-85	FUEL INJECTOR DRIVE – CYLINDER 8: TO ACTIVATE, ECM SWITCHES CIRCUIT TO GROUND

Rear Electronic Module

	Pin	Description and Characteristic
B+	CA100-8	IGNITION SWITCHED POWER SUPPLY (II): B+
B+	CA101-1	FUEL PUMP POWER SUPPLY: B+ WHEN FUEL PUMP RELAY IS ACTIVATED
SG	CA101-2	LOGIC GROUND / FUEL PUMP DRIVE SHIELD: GROUND
B+	CA101-3	BATTERY POWER SUPPLY: B+
O	CA101-11	FUEL PUMP SUPPLY VOLTAGE: B+
O	CA101-12	FUEL PUMP ACTIVATE: GROUND (PWM)
S	CA102-1	SCP +
S	CA102-2	SCP –
I	CA103-19	FUEL PUMP DRIVE SIGNAL: PWM, 150 Hz, NORMAL POSITIVE DUTY CYCLE RANGE = 4% – 51%

COMPONENTS

Component	Connector(s)	Connector Description	Location
AIR CONDITIONING COMPRESSOR CLUTCH	PI49	2-WAY / BLACK	LOWER LH SIDE OF ENGINE
AIR CONDITIONING COMPRESSOR CLUTCH RELAY	—	—	FRONT POWER DISTRIBUTION FUSE BOX – R8
AIR CONDITIONING PRESSURE SENSOR	FH110	4-WAY / BLACK	ENGINE COMPARTMENT, LH SIDE, HIGH PRESSURE REFRIGERANT LINE, BETWEEN COMPRESSOR AND CONDENSER
BRAKE CANCEL SWITCH	CA36	2-WAY / GREY	TOP OF BRAKE PEDAL
COOLING FAN MODULE	FH108 FH109	2-WAY / BLACK 2-WAY / BLACK	ENGINE COMPARTMENT, RH FRONT, REARWARD OF RADIATOR
ENGINE CONTROL MODULE	FH300 PI300	58-WAY / BLACK 96-WAY / BLACK	FRONT BULKHEAD, PASSENGER SIDE
FRONT POWER DISTRIBUTION FUSE BOX	—	—	ENGINE COMPARTMENT, RH SIDE
FUEL INJECTOR 1	PI32	2-WAY / BLACK	FUEL RAIL / INTAKE MANIFOLD
FUEL INJECTOR 2	PI36	2-WAY / BLACK	FUEL RAIL / INTAKE MANIFOLD
FUEL INJECTOR 3	PI33	2-WAY / BLACK	FUEL RAIL / INTAKE MANIFOLD
FUEL INJECTOR 4	PI37	2-WAY / BLACK	FUEL RAIL / INTAKE MANIFOLD
FUEL INJECTOR 5	P34	2-WAY / BLACK	FUEL RAIL / INTAKE MANIFOLD
FUEL INJECTOR 6	PI38	2-WAY / BLACK	FUEL RAIL / INTAKE MANIFOLD
FUEL INJECTOR 7	PI35	2-WAY / BLACK	FUEL RAIL / INTAKE MANIFOLD
FUEL INJECTOR 8	PI39	2-WAY / BLACK	FUEL RAIL / INTAKE MANIFOLD
FUEL PUMP	FP16	6-WAY / BLACK	FUEL TANK, RH SIDE
FUEL PUMP RELAY	—	—	REAR POWER DISTRIBUTION FUSE BOX – R15
IGNITION CAPACITOR	PI54	2-WAY / BLACK	LH CYLINDER HEAD, REAR
IGNITION MODULE AND COIL 1	PI2	4-WAY / BLACK	RH CYLINDER HEAD
IGNITION MODULE AND COIL 2	PI6	4-WAY / BLACK	LH CYLINDER HEAD
IGNITION MODULE AND COIL 3	PI3	4-WAY / BLACK	RH CYLINDER HEAD
IGNITION MODULE AND COIL 4	PI7	4-WAY / BLACK	LH CYLINDER HEAD
IGNITION MODULE AND COIL 5	PI4	4-WAY / BLACK	RH CYLINDER HEAD
IGNITION MODULE AND COIL 6	PI8	4-WAY / BLACK	LH CYLINDER HEAD
IGNITION MODULE AND COIL 7	PI5	4-WAY / BLACK	RH CYLINDER HEAD
IGNITION MODULE AND COIL 8	PI9	4-WAY / BLACK	LH CYLINDER HEAD
LEAK DETECTION UNIT	CA401	4-WAY / BLACK	ABOVE FUEL TANK
REAR ELECTRONIC MODULE	CA63 CA100 CA101 CA102 CA103	17-WAY / BLACK 12-WAY / BLACK 20-WAY / BLACK 22-WAY / BLACK 26-WAY / NATURAL	LUGGAGE COMPARTMENT, RH REAR
REAR POWER DISTRIBUTION FUSE BOX	—	—	LUGGAGE COMPARTMENT
STEERING WHEEL SPEED CONTROL SWITCHES	SQ2	6-WAY / BLACK	STEERING WHEEL

HARNESS IN-LINE CONNECTORS

Connector	Connector Description / Location	Location
FC10	14-WAY / GREEN / FASCIA HARNESS TO FRONT HARNESS	BEHIND INSTRUMENT PANEL, RH SIDE
FC117	10-WAY / BLACK / STEERING WHEEL CASSETTE	STEERING COLUMN
FH1	22-WAY / DARK GREY / CABIN HARNESS TO FRONT HARNESS	RH 'A' POST LOWER
FH3	16-WAY / BLUE / CABIN HARNESS TO FRONT HARNESS	LH 'A' POST
FP4	8-WAY / GREY / FUEL TANK HARNESS TO VEHICLE HARNESS	BIW ABOVE FUEL TANK, RH SIDE
PI41	42-WAY / BLACK / ENGINE HARNESS TO VEHICLE HARNESSES	ENGINE COMPARTMENT, BULKHEAD, PASSENGER SIDE

GROUNDS

Ground	Location
CA30	LOWER 'A' POST, LH SIDE
CA50	LOWER 'A' POST, RH SIDE
CA156	LUGGAGE COMPARTMENT, RH SIDE
FH22	ENGINE COMPARTMENT, BEHIND LH HEADLAMP
FH42	ENGINE COMPARTMENT, BEHIND RH HEADLAMP
FH95	ENGINE COMPARTMENT, BEHIND LH HEADLAMP (RADIATOR FAN GROUND)
PI51	ENGINE COMPARTMENT, ENGINE BLOCK

FOR CONTROL MODULE PIN-OUT INFORMATION, UNFOLD PAGE TO LEFT.

The following abbreviations are used to represent values for Control Module Pin-Out data

I	Input	PG	Power Ground	C	CAN Network	D	Serial and Encoded Data
O	Output	SS	Sensor / Signal Supply V	S	SCP Network	V	Voltage (DC)
B+	Battery Voltage	SG	Sensor / Signal Ground	D2	D2B Network	PWM	Pulse Width Modulated

CAUTION: The information on this data page is furnished to aid the user in understanding circuit operation. THIS INFORMATION SHOULD BE USED FOR REFERENCE ONLY.

NOTE: The values listed are approximately those that can be expected at the control module connector pins with all circuit connections made and all components connected and fitted.

Refer to the front of this book for detailed information and illustrations regarding the location and identification of harnesses, relays, fuses, grounds, control modules and control module pins.

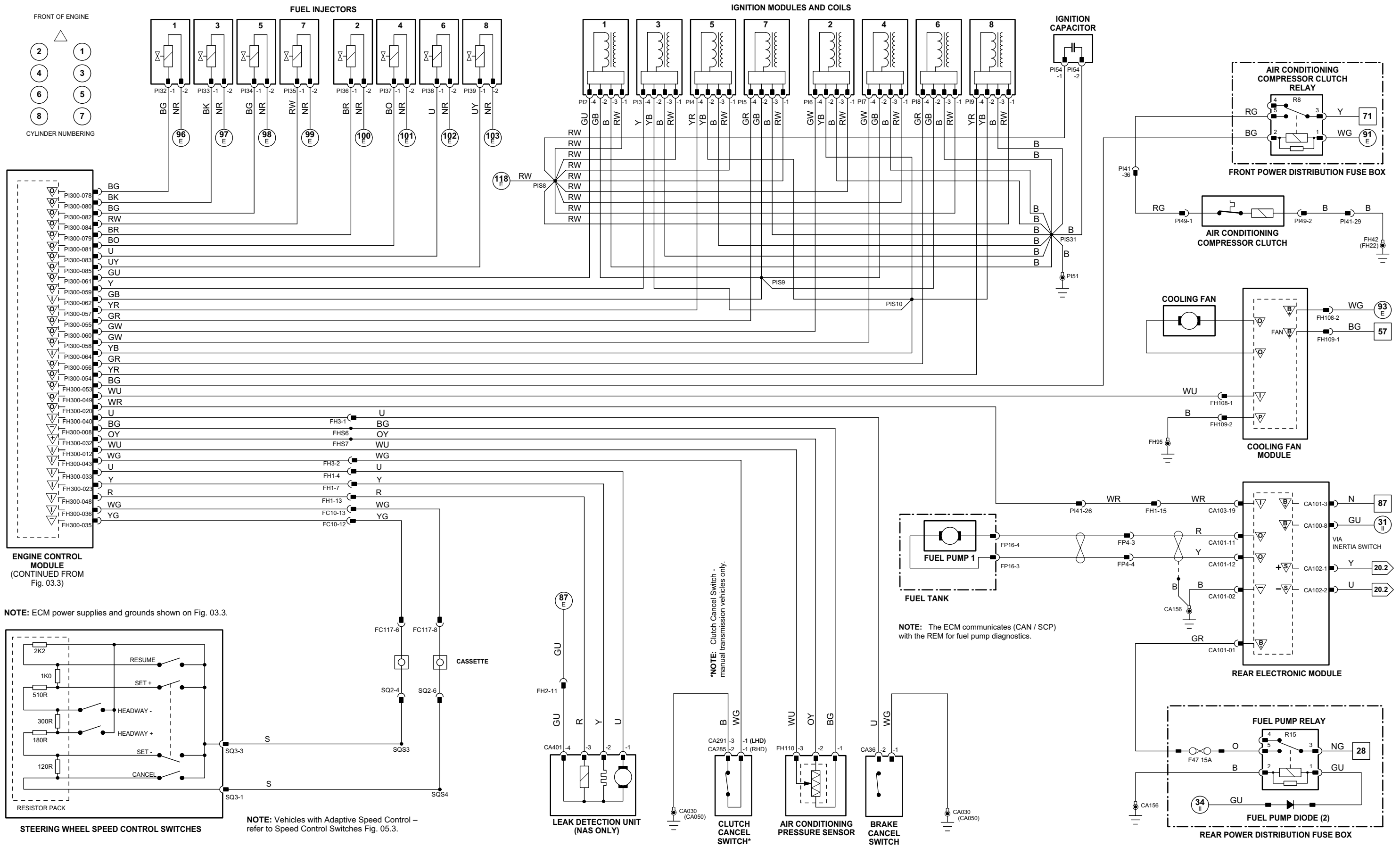

1 → 3	4 → 76	77 → 92	1 → 14	15 → 45	46 → 80	81 → 118	Input	Battery Voltage	Sensor/Signal Supply V	CAN	D2B Network
Fig. 01.1	Fig. 01.2	Fig. 01.3	Fig. 01.4	Fig. 01.5	Fig. 01.6	Fig. 01.7	Output	Power Ground	Sensor/Signal Ground	SCP	Serial and Encoded Data

VARIANT: V8 N/A Vehicles
VIN RANGE: All
DATE OF ISSUE: April 2006

Engine Control Module

	Pin	Description and Characteristic
SG	FH300-01	SMALL SIGNAL GROUND 1: GROUND
PG	FH300-02	POWER GROUND 1: GROUND
PG	FH300-03	POWER GROUND 2: GROUND
B+	FH300-04	EMS SWITCHED POWER SUPPLY 1: B+
PG	FH300-05	POWER GROUND 3: GROUND
B+	FH300-06	EMS SWITCHED POWER SUPPLY 2: B+
SG	FH300-07	SENSOR GROUND 1: GROUND
SG	FH300-08	SENSOR GROUND 2: GROUND
I	FH300-15	AUTOMATIC - PARK / NEUTRAL SIGNAL: B+ WHEN ACTIVATED MANUAL, ROW - PARK / NEUTRAL SIGNAL: B+ WHEN IGNITION CRANK (III) EMS CONTROL RELAY DRIVE: TO ACTIVATE, ECM SWITCHES CIRCUIT TO GROUND
O	FH300-16	ENGINE CRANK: B+
I	FH300-17	SENSOR POWER SUPPLY 2: NOMINAL 5 V
SS	FH300-19	ACCELERATOR PEDAL POSITION SENSOR 1 SIGNAL: FOOT OFF = 0.75 V; FULLY DEPRESSED = 3.40 V (AUTO) 3.20 V (MAN)
I	FH300-24	IGNITION ON: B+
SS	FH300-30	SENSOR POWER SUPPLY 1: NOMINAL 5 V
I	FH300-32	ACCELERATOR PEDAL POSITION SENSOR 2 SIGNAL: FOOT OFF = 3.38 V; FULLY DEPRESSED = 2.05 V (AUTO) 2.14 V (MAN)
I	FH300-38	BRAKE ON / OFF SWITCH: NORMALLY OPEN / B+ WHEN ACTIVATED
I	FH300-41	INERTIA SWITCH: NORMALLY CLOSED / OPEN CIRCUIT WHEN ACTIVATED
I	FH300-42	CAM -
C	FH300-45	STARTER RELAY DRIVE: TO ACTIVATE, ECM SWITCHES CIRCUIT TO GROUND
O	FH300-51	BATTERY POWER SUPPLY: B+
B+	FH300-54	CAM +
O	FH300-58	CAM +
SG	PI300-06	CRANKSHAFT SENSOR SIGNAL GROUND: GROUND
SG	PI300-07	BANK 1 CAMSHAFT SENSOR GROUND: GROUND
SG	PI300-08	BANK 2 CAMSHAFT SENSOR GROUND: GROUND
SG	PI300-10	SENSOR GROUND: GROUND
SG	PI300-11	THROTTLE POSITION SENSOR GROUND: GROUND
SG	PI300-12	SENSOR GROUND: GROUND
SG	PI300-15	SENSOR GROUND: GROUND
I	PI300-16	GENERATOR FAULT: CHARGE WARNING
SG	PI300-18	MASS AIR FLOW SENSOR GROUND: GROUND
SG	PI300-19	BANK 1 KNOCK SENSOR GROUND: GROUND
SG	PI300-20	BANK 2 KNOCK SENSOR GROUND: GROUND
SG	PI300-22	HO2 SENSORS 1/2 SHIELD: GROUND
I	PI300-23	ENGINE OIL TEMPERATURE SENSOR SIGNAL, NOMINAL 0 - 5 V: NTC SENSOR - VOLTAGE DECREASES AS TEMPERATURE INCREASES
SS	PI300-24	SENSOR POWER SUPPLY: NOMINAL 5V
I	PI300-26	HO2 SENSOR 2/1 SIGNAL: VARIABLE CURRENT
I	PI300-27	HO2 SENSOR 2/1 SIGNAL: CONSTANT CURRENT
I	PI300-28	HO2 SENSOR 1/1 SIGNAL: VARIABLE CURRENT
I	PI300-29	HO2 SENSOR 1/1 SIGNAL: CONSTANT CURRENT
I	PI300-30	CRANKSHAFT SENSOR SIGNAL: PULSED SIGNAL, 70 PULSES PER ENGINE CYCLE
I	PI300-33	BANK 2 CAMSHAFT SENSOR SIGNAL: PULSED SIGNAL, 4 PULSES PER ENGINE CYCLE
I	PI300-34	BANK 1 CAMSHAFT SENSOR SIGNAL: PULSED SIGNAL, 4 PULSES PER ENGINE CYCLE
I	PI300-38	THROTTLE BODY (THR) SENSOR SIGNAL, NOMINAL 0 - 5 V: VOLTAGE INCREASES AS PRESSURE INCREASES
I	PI300-39	TMAP SENSOR TEMPERATURE SIGNAL, NOMINAL 0 - 5 V: NTC SENSOR - VOLTAGE DECREASES AS TEMPERATURE INCREASES
I	PI300-40	HO2 SENSOR 1/2 SIGNAL, NOMINAL 1 V SWING: 0.1 - 0.9 V SWING
I	PI300-41	HO2 SENSOR 2/2 SIGNAL, NOMINAL 1 V SWING: 0.1 - 0.9 V SWING
I	PI300-42	BANK 1 KNOCK SENSOR SIGNAL: VARIABLE VOLTAGE DEPENDENT ON ENGINE VIBRATION
I	PI300-43	BANK 2 KNOCK SENSOR SIGNAL: VARIABLE VOLTAGE DEPENDENT ON ENGINE VIBRATION
SG	PI300-45	HO2 SENSORS 2/2 SHIELD: GROUND
I	PI300-46	ENGINE FUEL TEMPERATURE SENSOR SIGNAL, NOMINAL 0 - 5 V: NTC SENSOR - VOLTAGE DECREASES AS TEMPERATURE INCREASES
SS	PI300-47	SENSOR POWER SUPPLY: NOMINAL 5V
O	PI300-50	EGR DRIVE 4: B+; EGR DRIVE 1, 2, 3, 4 ARE OPERATED IN TURN
O	PI300-51	EGR DRIVE 3: B+; EGR DRIVE 1, 2, 3, 4 ARE OPERATED IN TURN
O	PI300-52	EGR DRIVE 2: B+; EGR DRIVE 1, 2, 3, 4 ARE OPERATED IN TURN
O	PI300-53	EGR DRIVE 1: B+; EGR DRIVE 1, 2, 3, 4 ARE OPERATED IN TURN
I	PI300-65	THROTTLE POSITION SENSOR 1 SIGNAL: IDLE = 0.60 V; FULL THROTTLE = 4.30 V
I	PI300-66	INTAKE AIR TEMPERATURE SENSOR SIGNAL, NOMINAL 0 - 5 V: NTC SENSOR - VOLTAGE DECREASES AS TEMPERATURE INCREASES
I	PI300-67	THROTTLE POSITION SENSOR 2 SIGNAL: IDLE = 1.48 V; FULL THROTTLE = 4.40 V
I	PI300-68	ENGINE COOLANT TEMPERATURE SENSOR SIGNAL, NOMINAL 0 - 5 V: NTC SENSOR - VOLTAGE DECREASES AS TEMPERATURE INCREASES
I	PI300-69	TMAP SENSOR SIGNAL, NOMINAL 0 - 5 V: VOLTAGE INCREASES AS MANIFOLD ABSOLUTE PRESSURE INCREASES
I	PI300-70	MASS AIR FLOW SENSOR SIGNAL: NOMINAL 0 - 5 V BY ENGINE OPERATING CONDITION
I	PI300-71	INJECTION PRESSURE SENSOR SIGNAL, NOMINAL 0 - 5 V: POTENTIOMETER - VOLTAGE INCREASES AS PRESSURE INCREASES
SS	PI300-72	THROTTLE POSITION SENSOR POWER SUPPLY: NOMINAL 5 V
O	PI300-74	THROTTLE MOTOR GROUND: GROUND
O	PI300-75	THROTTLE MOTOR DRIVE: B+ TO ACTIVATE MOTOR
O	PI300-76	HO2 SENSOR HEATER CONTROL - 1/1: PWM, 1 CYCLE PER 128 mS, VARIABLE DUTY CYCLE
O	PI300-77	HO2 SENSOR HEATER CONTROL - 2/1: PWM, 1 CYCLE PER 128 mS, VARIABLE DUTY CYCLE
O	PI300-86	BANK 1 VVT SOLENOID VALVE: PWM, 300 Hz, POSITIVE DUTY CYCLE RANGE 0% - 100%
O	PI300-87	BANK 2 VVT SOLENOID VALVE: PWM, 300 Hz, POSITIVE DUTY CYCLE RANGE 0% - 100%
O	PI300-88	HO2 SENSOR HEATER CONTROL - 1/2: PWM, 1 CYCLE PER 256 mS, POSITIVE DUTY CYCLE RANGE 0 mS = 0%, 77 mS = 30%, 256 mS = 100%
O	PI300-89	HO2 SENSOR HEATER CONTROL - 2/2: PWM, 1 CYCLE PER 256 mS, POSITIVE DUTY CYCLE RANGE 0 mS = 0%, 77 mS = 30%, 256 mS = 100%
O	PI300-92	EVAP CANISTER PURGE VALVE DRIVE: PWM, 10 Hz, POSITIVE DUTY CYCLE RANGE 7% - 100%
O	PI300-94	INTERCOOLER PUMP RELAY DRIVE

The following abbreviations are used to represent values for Control Module Pin-Out data

I	Input	PG	Power Ground	C	CAN Network	D	Serial and Encoded Data
O	Output	SS	Sensor / Signal Supply V	S	SCP Network	V	Voltage (DC)
B+	Battery Voltage	SG	Sensor / Signal Ground	D2	D2B Network	PWM	Pulse Width Modulated

CAUTION: The information on this data page is furnished to aid the user in understanding circuit operation. THIS INFORMATION SHOULD BE USED FOR REFERENCE ONLY.

NOTE: The values listed are approximately those that can be expected at the control module connector pins with all circuit connections made and all components connected and fitted.

Fig. 03.5

COMPONENTS

Component	Connector(s)	Connector Description	Location
APP SENSOR	CA88	6-WAY / BLACK	TOP OF ACCELERATOR PEDAL
BRAKE ON / OFF SWITCH	CA37	2-WAY / GREEN	TOP OF BRAKE PEDAL
CKP SENSOR	PI21	2-WAY / BLACK	ENGINE TIMING COVER, CRANKSHAFT PULLEY
CMP SENSOR 1	PI23	2-WAY / BLACK	BANK 1 (RH) CAMSHAFT COVER, FRONT
CMP SENSOR 2	PI22	2-WAY / BLACK	BANK 2 (LH) CAMSHAFT COVER, FRONT
ECT SENSOR	PI25	2-WAY / BLACK	ENGINE VEE, COOLANT OUTLET CASTING
EFT SENSOR	IL9	2-WAY / BLACK	FUEL RAIL, FRONT
EGR VALVE	PI15	6-WAY / BLACK	INTAKE MANIFOLD, RH FRONT
ENGINE CONTROL MODULE	FH300	58-WAY / BLACK	FRONT BULKHEAD, PASSENGER SIDE
	PI300	96-WAY / BLAVK	FRONT BULKHEAD, PASSENGER SIDE
EOT SENSOR	PI24	2-WAY / BLACK	ADJACENT TO OIL FILTER
EVAP CANISTER PURGE VALVE	PI304	2-WAY / BLACK	ENGINE COMPARTMENT, LH SIDE, ADJACENT TO SUSPENSION TURRET
HO2 SENSOR DOWNSTREAM 1/2	PI11	4-WAY / BLACK	RH EXHAUST, CATALYST CENTER
HO2 SENSOR DOWNSTREAM 2/2	PI13	4-WAY / BLACK	LH EXHAUST, CATALYST CENTER
HO2 SENSOR UPSTREAM 1/1	PI10	4-WAY / BLACK	RH EXHAUST, TOP OF CATALYST
HO2 SENSOR UPSTREAM 2/1	PI12	4-WAY / BLACK	LH EXHAUST, TOP OF CATALYST
IP SENSOR	PI28	3-WAY / BLACK	FUEL RAIL, REAR
KNOCK SENSOR 1	PI43	2-WAY / BLACK	ENGINE VEE, TOWARD FRONT, BANK 2 (FRONT SENSOR)
KNOCK SENSOR 2	PI44	2-WAY / BLACK	ENGINE BLOCK, REAR, BANK 1 (REAR SENSOR)
MAF SENSOR	PI14	5-WAY / BLACK	ENGINE AIR INTAKE, ADJACENT TO AIR CLEANER
TMAP SENSOR	PI29	4-WAY / BLACK	INTAKE MANIFOLD, UPPER REAR
THR SENSOR	PI301	4-WAY / BLACK	ENGINE, RH REAR
THROTTLE MOTOR	—	—	THROTTLE BODY
TP SENSOR	—	—	THROTTLE BODY
VVT SOLENOID VALVE 1	PI16	2-WAY / BLACK	RH CYLINDER HEAD, FRONT
VVT SOLENOID VALVE 2	PI17	2-WAY / BLACK	LH CYLINDER HEAD, FRONT

HARNESS IN-LINE CONNECTORS

Connector	Connector Description / Location	Location
FC12	14-WAY / GREY / FASCIA HARNESS TO FRONT HARNESS	BEHIND INSTRUMENT PANEL, PASSENGER SIDE
FC26	16-WAY / BLUE / CABIN HARNESS TO FASCIA HARNESS	BEHIND INSTRUMENT PANEL, DRIVER SIDE
FH1	22-WAY / DARK GREY / CABIN HARNESS TO FRONT HARNESS	RH 'A' POST, LOWER

GROUND S

Ground	Location
FH4 (LHD)	ENGINE COMPARTMENT, BEHIND RH WHEEL ARCH LINER
FH4 (RHD)	ENGINE COMPARTMENT, BEHIND LH WHEEL ARCH LINER

FOR CONTROL MODULE PIN-OUT INFORMATION, UNFOLD PAGE TO LEFT.

Refer to the front of this book for detailed information and illustrations regarding the location and identification of harnesses, relays, fuses, grounds, control modules and control module pins.

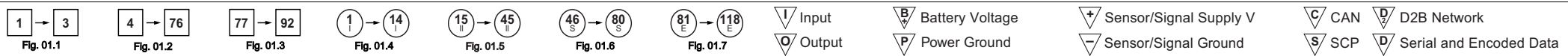
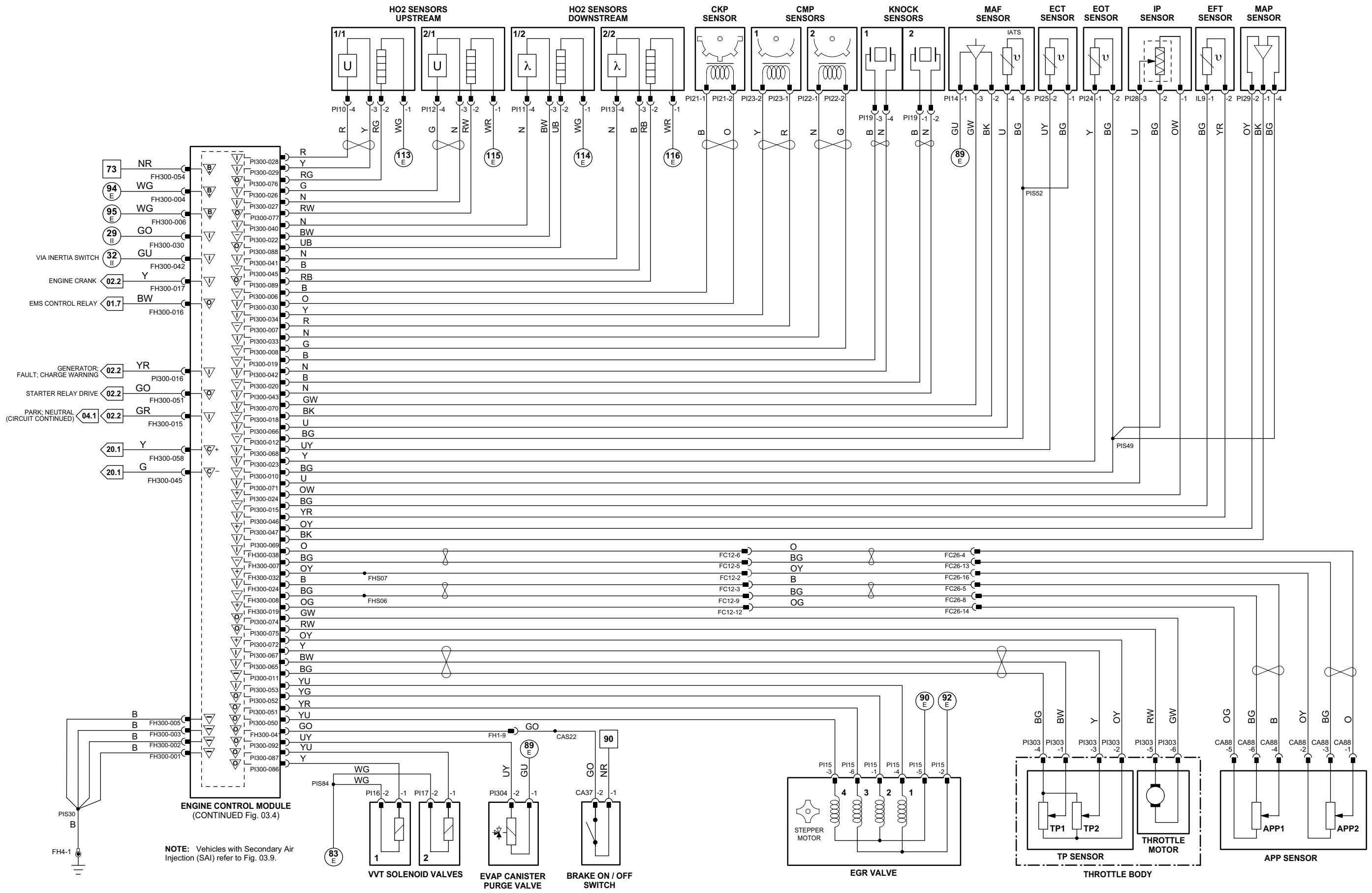

VARIANT: V8 N/A Vehicles
 VIN RANGE: All
 DATE OF ISSUE: April 2006

Fig. 03.4

Engine Control Module

	Pin	Description and Characteristic
SG	FH300-08	SENSOR GROUND 1: GROUND
I	FH300-12	AIR CONDITIONING PRESSURE SENSOR SIGNAL, NOMINAL 0 – 5 V: TRANSDUCER – VOLTAGE INCREASES AS PRESSURE INCREASES
O	FH300-20	FUEL PUMP DRIVE SIGNAL (TO REM): PWM, 150 Hz, NORMAL POSITIVE DUTY CYCLE RANGE = 4% – 51%
O	FH300-23	LEAK DETECTION HEATER CONTROL
SS	FH300-32	SENSOR POWER SUPPLY 1: NOMINAL 5 V
O	FH300-33	LEAK DETECTION PUMP CONTROL
I	FH300-35	SPEED CONTROL SWITCHES SIGNAL GROUND: GROUND
SS	FH300-36	SPEED CONTROL SWITCH REQUEST: STEPPED RESISTANCE
I	FH300-40	BRAKE CANCEL SWITCH: NORMALLY CLOSED / GROUND WHEN ACTIVATED
I	FH300-43	CLUTCH CANCEL SWITCH: NORMALLY CLOSED / GROUND WHEN ACTIVATED
O	FH300-48	LEAK DETECTION VALVE CONTROL
O	FH300-49	COOLING FAN MODULE CONTROL: PWM, 140 Hz, POSITIVE DUTY CYCLE RANGE 7% – 95%
O	FH300-53	AIR CONDITIONING COMPRESSOR CLUTCH RELAY DRIVE: TO ACTIVATE, ECM SWITCHES CIRCUIT TO GROUND
O	P1300-55	IGNITION COIL ACTIVATE – CYLINDER 7: TO ACTIVATE, ECM SWITCHES CIRCUIT TO GROUND
O	P1300-56	IGNITION COIL ACTIVATE – CYLINDER 6: TO ACTIVATE, ECM SWITCHES CIRCUIT TO GROUND
O	P1300-56	IGNITION COIL ACTIVATE – CYLINDER 8: TO ACTIVATE, ECM SWITCHES CIRCUIT TO GROUND
O	P1300-57	IGNITION COIL ACTIVATE – CYLINDER 5: TO ACTIVATE, ECM SWITCHES CIRCUIT TO GROUND
O	P1300-58	IGNITION COIL ACTIVATE – CYLINDER 4: TO ACTIVATE, ECM SWITCHES CIRCUIT TO GROUND
O	P1300-59	IGNITION COIL ACTIVATE – CYLINDER 3: TO ACTIVATE, ECM SWITCHES CIRCUIT TO GROUND
O	P1300-60	IGNITION COIL ACTIVATE – CYLINDER 2: TO ACTIVATE, ECM SWITCHES CIRCUIT TO GROUND
O	P1300-61	IGNITION COIL ACTIVATE – CYLINDER 1: TO ACTIVATE, ECM SWITCHES CIRCUIT TO GROUND
I	P1300-62	IGNITION MONITOR BANK 1: PULSED SIGNAL, 3 PULSES PER ENGINE CYCLE
I	P1300-64	IGNITION MONITOR BANK 2: PULSED SIGNAL, 3 PULSES PER ENGINE CYCLE
O	P1300-78	FUEL INJECTOR DRIVE – CYLINDER 1: TO ACTIVATE, ECM SWITCHES CIRCUIT TO GROUND
O	P1300-79	FUEL INJECTOR DRIVE – CYLINDER 2: TO ACTIVATE, ECM SWITCHES CIRCUIT TO GROUND
O	P1300-80	FUEL INJECTOR DRIVE – CYLINDER 3: TO ACTIVATE, ECM SWITCHES CIRCUIT TO GROUND
O	P1300-81	FUEL INJECTOR DRIVE – CYLINDER 4: TO ACTIVATE, ECM SWITCHES CIRCUIT TO GROUND
O	P1300-82	FUEL INJECTOR DRIVE – CYLINDER 5: TO ACTIVATE, ECM SWITCHES CIRCUIT TO GROUND
O	P1300-83	FUEL INJECTOR DRIVE – CYLINDER 6: TO ACTIVATE, ECM SWITCHES CIRCUIT TO GROUND
O	P1300-84	FUEL INJECTOR DRIVE – CYLINDER 7: TO ACTIVATE, ECM SWITCHES CIRCUIT TO GROUND
O	P1300-85	FUEL INJECTOR DRIVE – CYLINDER 8: TO ACTIVATE, ECM SWITCHES CIRCUIT TO GROUND

Rear Electronic Module

	Pin	Description and Characteristic
B+	CA100-8	IGNITION SWITCHED POWER SUPPLY (II): B+
B+	CA101-1	FUEL PUMP POWER SUPPLY: B+ WHEN FUEL PUMP RELAY IS ACTIVATED
SG	CA101-2	LOGIC GROUND / FUEL PUMP DRIVE SHIELD: GROUND
B+	CA101-3	BATTERY POWER SUPPLY: B+
O	CA101-11	FUEL PUMP SUPPLY VOLTAGE: B+
O	CA101-12	FUEL PUMP ACTIVATE: GROUND (PWM)
S	CA102-1	SCP +
S	CA102-2	SCP –
I	CA103-19	FUEL PUMP DRIVE SIGNAL: PWM, 150 Hz, NORMAL POSITIVE DUTY CYCLE RANGE = 4% – 51%

COMPONENTS

Component	Connector(s)	Connector Description	Location
AIR CONDITIONING COMPRESSOR CLUTCH	PI49	2-WAY / BLACK	LOWER LH SIDE OF ENGINE
AIR CONDITIONING COMPRESSOR CLUTCH RELAY	—	—	FRONT POWER DISTRIBUTION FUSE BOX – R8
AIR CONDITIONING PRESSURE SENSOR	FH110	4-WAY / BLACK	ENGINE COMPARTMENT, LH SIDE, HIGH PRESSURE REFRIGERANT LINE, BETWEEN COMPRESSOR AND CONDENSER
BRAKE CANCEL SWITCH	CA36	2-WAY / GREY	TOP OF BRAKE PEDAL
COOLING FAN MODULE	FH108 FH109	2-WAY / BLACK 2-WAY / BLACK	ENGINE COMPARTMENT, RH FRONT, REARWARD OF RADIATOR
ENGINE CONTROL MODULE	FH300 PI300	58-WAY / BLACK 96-WAY / BLACK	FRONT BULKHEAD, PASSENGER SIDE
FRONT POWER DISTRIBUTION FUSE BOX	—	—	ENGINE COMPARTMENT, RH SIDE
FUEL INJECTOR 1	PI32	2-WAY / BLACK	FUEL RAIL / INTAKE MANIFOLD
FUEL INJECTOR 2	PI36	2-WAY / BLACK	FUEL RAIL / INTAKE MANIFOLD
FUEL INJECTOR 3	PI33	2-WAY / BLACK	FUEL RAIL / INTAKE MANIFOLD
FUEL INJECTOR 4	PI37	2-WAY / BLACK	FUEL RAIL / INTAKE MANIFOLD
FUEL INJECTOR 5	P34	2-WAY / BLACK	FUEL RAIL / INTAKE MANIFOLD
FUEL INJECTOR 6	PI38	2-WAY / BLACK	FUEL RAIL / INTAKE MANIFOLD
FUEL INJECTOR 7	PI35	2-WAY / BLACK	FUEL RAIL / INTAKE MANIFOLD
FUEL INJECTOR 8	PI39	2-WAY / BLACK	FUEL RAIL / INTAKE MANIFOLD
FUEL PUMP	FP16	6-WAY / BLACK	FUEL TANK, RH SIDE
FUEL PUMP RELAY	—	—	REAR POWER DISTRIBUTION FUSE BOX – R15
IGNITION CAPACITOR	PI54	2-WAY / BLACK	LH CYLINDER HEAD, REAR
IGNITION MODULE AND COIL 1	PI2	4-WAY / BLACK	RH CYLINDER HEAD
IGNITION MODULE AND COIL 2	PI6	4-WAY / BLACK	LH CYLINDER HEAD
IGNITION MODULE AND COIL 3	PI3	4-WAY / BLACK	RH CYLINDER HEAD
IGNITION MODULE AND COIL 4	PI7	4-WAY / BLACK	LH CYLINDER HEAD
IGNITION MODULE AND COIL 5	PI4	4-WAY / BLACK	RH CYLINDER HEAD
IGNITION MODULE AND COIL 6	PI8	4-WAY / BLACK	LH CYLINDER HEAD
IGNITION MODULE AND COIL 7	PI5	4-WAY / BLACK	RH CYLINDER HEAD
IGNITION MODULE AND COIL 8	PI9	4-WAY / BLACK	LH CYLINDER HEAD
LEAK DETECTION UNIT	CA401	4-WAY / BLACK	ABOVE FUEL TANK
REAR ELECTRONIC MODULE	CA63 CA100 CA101 CA102 CA103	17-WAY / BLACK 12-WAY / BLACK 20-WAY / BLACK 22-WAY / BLACK 26-WAY / NATURAL	LUGGAGE COMPARTMENT, RH REAR
REAR POWER DISTRIBUTION FUSE BOX	—	—	LUGGAGE COMPARTMENT
STEERING WHEEL SPEED CONTROL SWITCHES	SQ2	6-WAY / BLACK	STEERING WHEEL

HARNESS IN-LINE CONNECTORS

Connector	Connector Description / Location	Location
FC10	14-WAY / GREEN / FASCIA HARNESS TO FRONT HARNESS	BEHIND INSTRUMENT PANEL, RH SIDE
FC117	10-WAY / BLACK / STEERING WHEEL CASSETTE	STEERING COLUMN
FH1	22-WAY / DARK GREY / CABIN HARNESS TO FRONT HARNESS	RH 'A' POST LOWER
FH3	16-WAY / BLUE / CABIN HARNESS TO FRONT HARNESS	LH 'A' POST
FP4	8-WAY / GREY / FUEL TANK HARNESS TO VEHICLE HARNESS	BIW ABOVE FUEL TANK, RH SIDE
PI41	42-WAY / BLACK / ENGINE HARNESS TO VEHICLE HARNESSES	ENGINE COMPARTMENT, BULKHEAD, PASSENGER SIDE

GROUNDS

Ground	Location
CA30	LOWER 'A' POST, LH SIDE
CA50	LOWER 'A' POST, RH SIDE
CA156	LUGGAGE COMPARTMENT, RH SIDE
FH22	ENGINE COMPARTMENT, BEHIND LH HEADLAMP
FH42	ENGINE COMPARTMENT, BEHIND RH HEADLAMP
FH95	ENGINE COMPARTMENT, BEHIND LH HEADLAMP (RADIATOR FAN GROUND)
PI51	ENGINE COMPARTMENT, ENGINE BLOCK

FOR CONTROL MODULE PIN-OUT INFORMATION, UNFOLD PAGE TO LEFT.

The following abbreviations are used to represent values for Control Module Pin-Out data

I	Input	PG	Power Ground	C	CAN Network	D	Serial and Encoded Data
O	Output	SS	Sensor / Signal Supply V	S	SCP Network	V	Voltage (DC)
B+	Battery Voltage	SG	Sensor / Signal Ground	D2	D2B Network	PWM	Pulse Width Modulated

CAUTION: The information on this data page is furnished to aid the user in understanding circuit operation. THIS INFORMATION SHOULD BE USED FOR REFERENCE ONLY.

NOTE: The values listed are approximately those that can be expected at the control module connector pins with all circuit connections made and all components connected and fitted.

Refer to the front of this book for detailed information and illustrations regarding the location and identification of harnesses, relays, fuses, grounds, control modules and control module pins.

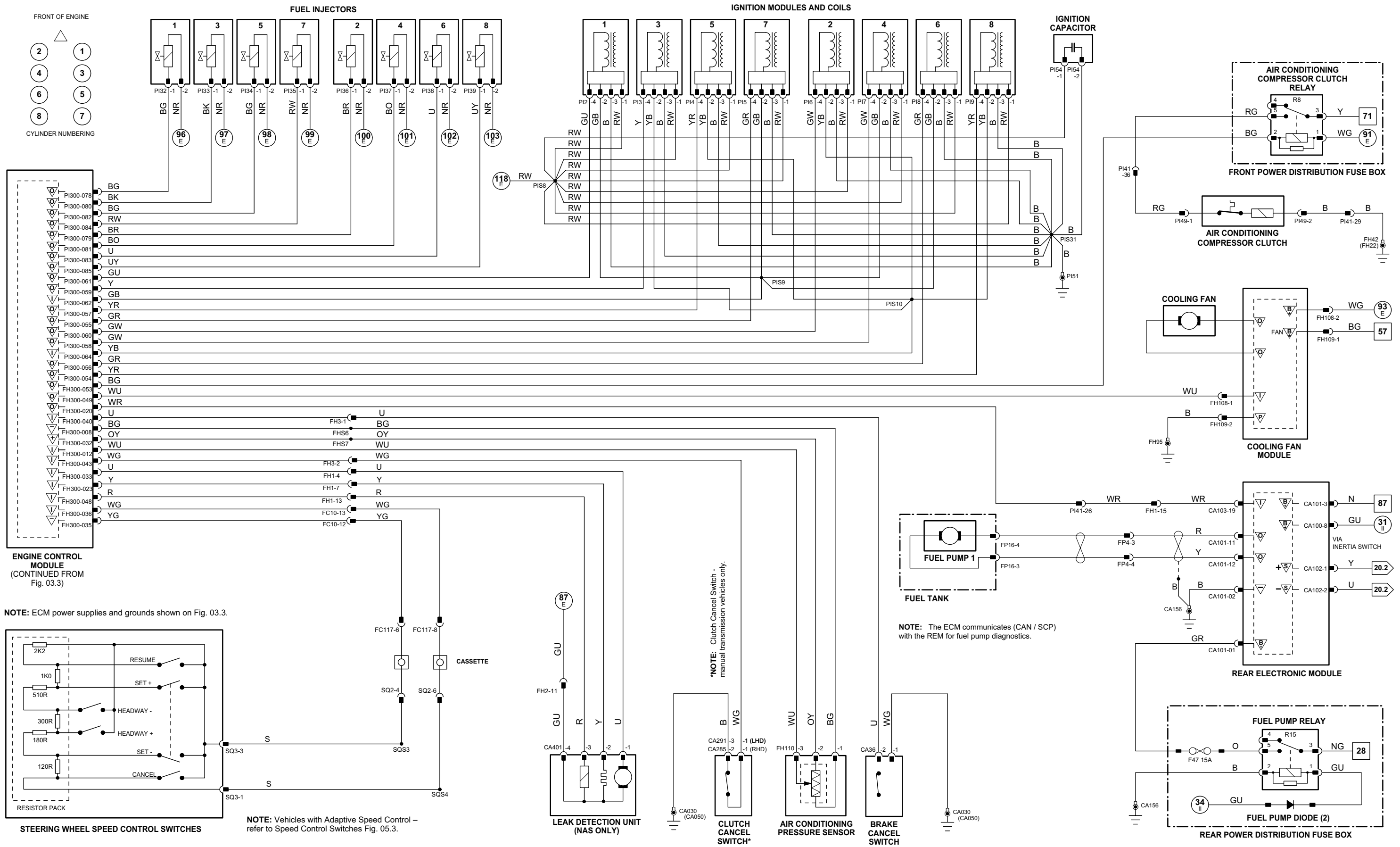

1 → 3	4 → 76	77 → 92	1 → 14	15 → 45	46 → 80	81 → 118	Input	Battery Voltage	Sensor/Signal Supply V	CAN	D2B Network
Fig. 01.1	Fig. 01.2	Fig. 01.3	Fig. 01.4	Fig. 01.5	Fig. 01.6	Fig. 01.7	Output	Power Ground	Sensor/Signal Ground	SCP	Serial and Encoded Data

VARIANT: V8 N/A Vehicles
 VIN RANGE: All
 DATE OF ISSUE: April 2006

Engine Control Module

	Pin	Description and Characteristic
SG	FH300-01	SMALL SIGNAL GROUND 1: GROUND
PG	FH300-02	POWER GROUND 1: GROUND
PG	FH300-03	POWER GROUND 2: GROUND
B+	FH300-04	EMS SWITCHED POWER SUPPLY 1: B+
PG	FH300-05	POWER GROUND 3: GROUND
B+	FH300-06	EMS SWITCHED POWER SUPPLY 2: B+
SG	FH300-07	SENSOR GROUND 1: GROUND
SG	FH300-08	SENSOR GROUND 2: GROUND
I	FH300-15	AUTOMATIC - PARK / NEUTRAL SIGNAL: B+ WHEN ACTIVATED MANUAL, ROW - PARK / NEUTRAL SIGNAL: B+ WHEN IGNITION CRANK (III) EMS CONTROL RELAY DRIVE: TO ACTIVATE, ECM SWITCHES CIRCUIT TO GROUND
O	FH300-16	ENGINE CRANK: B+
I	FH300-17	SENSOR POWER SUPPLY 2: NOMINAL 5 V
SS	FH300-19	ACCELERATOR PEDAL POSITION SENSOR 1 SIGNAL: FOOT OFF = 0.75 V; FULLY DEPRESSED = 3.40 V (AUTO) 3.20 V (MAN)
I	FH300-24	IGNITION ON: B+
SS	FH300-30	SENSOR POWER SUPPLY 1: NOMINAL 5 V
I	FH300-32	ACCELERATOR PEDAL POSITION SENSOR 2 SIGNAL: FOOT OFF = 3.38 V; FULLY DEPRESSED = 2.05 V (AUTO) 2.14 V (MAN)
I	FH300-38	BRAKE ON / OFF SWITCH: NORMALLY OPEN / B+ WHEN ACTIVATED
I	FH300-41	INERTIA SWITCH: NORMALLY CLOSED / OPEN CIRCUIT WHEN ACTIVATED
I	FH300-42	CAM -
C	FH300-45	STARTER RELAY DRIVE: TO ACTIVATE, ECM SWITCHES CIRCUIT TO GROUND
O	FH300-51	BATTERY POWER SUPPLY: B+
B+	FH300-54	CAM +
O	FH300-58	CAM +
SG	PI300-06	CRANKSHAFT SENSOR SIGNAL GROUND: GROUND
SG	PI300-07	BANK 1 CAMSHAFT SENSOR GROUND: GROUND
SG	PI300-08	BANK 2 CAMSHAFT SENSOR GROUND: GROUND
SG	PI300-10	SENSOR GROUND: GROUND
SG	PI300-11	THROTTLE POSITION SENSOR GROUND: GROUND
SG	PI300-12	SENSOR GROUND: GROUND
SG	PI300-15	SENSOR GROUND: GROUND
I	PI300-16	GENERATOR FAULT: CHARGE WARNING
SG	PI300-18	MASS AIR FLOW SENSOR GROUND: GROUND
SG	PI300-19	BANK 1 KNOCK SENSOR GROUND: GROUND
SG	PI300-20	BANK 2 KNOCK SENSOR GROUND: GROUND
SG	PI300-22	HO2 SENSORS 1/2 SHIELD: GROUND
I	PI300-23	ENGINE OIL TEMPERATURE SENSOR SIGNAL, NOMINAL 0 - 5 V: NTC SENSOR - VOLTAGE DECREASES AS TEMPERATURE INCREASES
SS	PI300-24	SENSOR POWER SUPPLY: NOMINAL 5V
I	PI300-26	HO2 SENSOR 2/1 SIGNAL: VARIABLE CURRENT
I	PI300-27	HO2 SENSOR 2/1 SIGNAL: CONSTANT CURRENT
I	PI300-28	HO2 SENSOR 1/1 SIGNAL: VARIABLE CURRENT
I	PI300-29	HO2 SENSOR 1/1 SIGNAL: CONSTANT CURRENT
I	PI300-30	CRANKSHAFT SENSOR SIGNAL: PULSED SIGNAL, 70 PULSES PER ENGINE CYCLE
I	PI300-33	BANK 2 CAMSHAFT SENSOR SIGNAL: PULSED SIGNAL, 4 PULSES PER ENGINE CYCLE
I	PI300-34	BANK 1 CAMSHAFT SENSOR SIGNAL: PULSED SIGNAL, 4 PULSES PER ENGINE CYCLE
I	PI300-38	THROTTLE BODY (THR) SENSOR SIGNAL, NOMINAL 0 - 5 V: VOLTAGE INCREASES AS PRESSURE INCREASES
I	PI300-39	TMAP SENSOR TEMPERATURE SIGNAL, NOMINAL 0 - 5 V: NTC SENSOR - VOLTAGE DECREASES AS TEMPERATURE INCREASES
I	PI300-40	HO2 SENSOR 1/2 SIGNAL, NOMINAL 1 V SWING: 0.1 - 0.9 V SWING
I	PI300-41	HO2 SENSOR 2/2 SIGNAL, NOMINAL 1 V SWING: 0.1 - 0.9 V SWING
I	PI300-42	BANK 1 KNOCK SENSOR SIGNAL: VARIABLE VOLTAGE DEPENDENT ON ENGINE VIBRATION
I	PI300-43	BANK 2 KNOCK SENSOR SIGNAL: VARIABLE VOLTAGE DEPENDENT ON ENGINE VIBRATION
SG	PI300-45	HO2 SENSORS 2/2 SHIELD: GROUND
I	PI300-46	ENGINE FUEL TEMPERATURE SENSOR SIGNAL, NOMINAL 0 - 5 V: NTC SENSOR - VOLTAGE DECREASES AS TEMPERATURE INCREASES
SS	PI300-47	SENSOR POWER SUPPLY: NOMINAL 5V
O	PI300-50	EGR DRIVE 4: B+; EGR DRIVE 1, 2, 3, 4 ARE OPERATED IN TURN
O	PI300-51	EGR DRIVE 3: B+; EGR DRIVE 1, 2, 3, 4 ARE OPERATED IN TURN
O	PI300-52	EGR DRIVE 2: B+; EGR DRIVE 1, 2, 3, 4 ARE OPERATED IN TURN
O	PI300-53	EGR DRIVE 1: B+; EGR DRIVE 1, 2, 3, 4 ARE OPERATED IN TURN
I	PI300-65	THROTTLE POSITION SENSOR 1 SIGNAL: IDLE = 0.60 V; FULL THROTTLE = 4.30 V
I	PI300-66	INTAKE AIR TEMPERATURE SENSOR SIGNAL, NOMINAL 0 - 5 V: NTC SENSOR - VOLTAGE DECREASES AS TEMPERATURE INCREASES
I	PI300-67	THROTTLE POSITION SENSOR 2 SIGNAL: IDLE = 1.48 V; FULL THROTTLE = 4.40 V
I	PI300-68	ENGINE COOLANT TEMPERATURE SENSOR SIGNAL, NOMINAL 0 - 5 V: NTC SENSOR - VOLTAGE DECREASES AS TEMPERATURE INCREASES
I	PI300-69	TMAP SENSOR SIGNAL, NOMINAL 0 - 5 V: VOLTAGE INCREASES AS MANIFOLD ABSOLUTE PRESSURE INCREASES
I	PI300-70	MASS AIR FLOW SENSOR SIGNAL: NOMINAL 0 - 5 V BY ENGINE OPERATING CONDITION
I	PI300-71	INJECTION PRESSURE SENSOR SIGNAL, NOMINAL 0 - 5 V: POTENTIOMETER - VOLTAGE INCREASES AS PRESSURE INCREASES
SS	PI300-72	THROTTLE POSITION SENSOR POWER SUPPLY: NOMINAL 5 V
O	PI300-74	THROTTLE MOTOR GROUND: GROUND
O	PI300-75	THROTTLE MOTOR DRIVE: B+ TO ACTIVATE MOTOR
O	PI300-76	HO2 SENSOR HEATER CONTROL - 1/1: PWM, 1 CYCLE PER 128 mS, VARIABLE DUTY CYCLE
O	PI300-77	HO2 SENSOR HEATER CONTROL - 2/1: PWM, 1 CYCLE PER 128 mS, VARIABLE DUTY CYCLE
O	PI300-86	BANK 1 VVT SOLENOID VALVE: PWM, 300 Hz, POSITIVE DUTY CYCLE RANGE 0% - 100%
O	PI300-87	BANK 2 VVT SOLENOID VALVE: PWM, 300 Hz, POSITIVE DUTY CYCLE RANGE 0% - 100%
O	PI300-88	HO2 SENSOR HEATER CONTROL - 1/2: PWM, 1 CYCLE PER 256 mS, POSITIVE DUTY CYCLE RANGE 0 mS = 0%, 77 mS = 30%, 256 mS = 100%
O	PI300-89	HO2 SENSOR HEATER CONTROL - 2/2: PWM, 1 CYCLE PER 256 mS, POSITIVE DUTY CYCLE RANGE 0 mS = 0%, 77 mS = 30%, 256 mS = 100%
O	PI300-92	EVAP CANISTER PURGE VALVE DRIVE: PWM, 10 Hz, POSITIVE DUTY CYCLE RANGE 7% - 100%
O	PI300-94	INTERCOOLER PUMP RELAY DRIVE

The following abbreviations are used to represent values for Control Module Pin-Out data

I	Input	PG	Power Ground	C	CAN Network	D	Serial and Encoded Data
O	Output	SS	Sensor / Signal Supply V	S	SCP Network	V	Voltage (DC)
B+	Battery Voltage	SG	Sensor / Signal Ground	D2	D2B Network	PWM	Pulse Width Modulated

CAUTION: The information on this data page is furnished to aid the user in understanding circuit operation. THIS INFORMATION SHOULD BE USED FOR REFERENCE ONLY.

NOTE: The values listed are approximately those that can be expected at the control module connector pins with all circuit connections made and all components connected and fitted.

Fig. 03.5

COMPONENTS

Component	Connector(s)	Connector Description	Location
APP SENSOR	CA88	6-WAY / BLACK	TOP OF ACCELERATOR PEDAL
BRAKE ON / OFF SWITCH	CA37	2-WAY / GREEN	TOP OF BRAKE PEDAL
CKP SENSOR	PI21	2-WAY / BLACK	ENGINE TIMING COVER, CRANKSHAFT PULLEY
CMP SENSOR 1	PI23	2-WAY / BLACK	BANK 1 (RH) CAMSHAFT COVER, FRONT
CMP SENSOR 2	PI22	2-WAY / BLACK	BANK 2 (LH) CAMSHAFT COVER, FRONT
ECT SENSOR	PI25	2-WAY / BLACK	ENGINE VEE, COOLANT OUTLET CASTING
EFT SENSOR	IL9	2-WAY / BLACK	FUEL RAIL, FRONT
EGR VALVE	PI15	6-WAY / BLACK	INTAKE MANIFOLD, RH FRONT
ENGINE CONTROL MODULE	FH300	58-WAY / BLACK	FRONT BULKHEAD, PASSENGER SIDE
	PI300	96-WAY / BLAVK	FRONT BULKHEAD, PASSENGER SIDE
EOT SENSOR	PI24	2-WAY / BLACK	ADJACENT TO OIL FILTER
EVAP CANISTER PURGE VALVE	PI304	2-WAY / BLACK	ENGINE COMPARTMENT, LH SIDE, ADJACENT TO SUSPENSION TURRET
HO2 SENSOR DOWNSTREAM 1/2	PI11	4-WAY / BLACK	RH EXHAUST, CATALYST CENTER
HO2 SENSOR DOWNSTREAM 2/2	PI13	4-WAY / BLACK	LH EXHAUST, CATALYST CENTER
HO2 SENSOR UPSTREAM 1/1	PI10	4-WAY / BLACK	RH EXHAUST, TOP OF CATALYST
HO2 SENSOR UPSTREAM 2/1	PI12	4-WAY / BLACK	LH EXHAUST, TOP OF CATALYST
IP SENSOR	PI28	3-WAY / BLACK	FUEL RAIL, REAR
KNOCK SENSOR 1	PI43	2-WAY / BLACK	ENGINE VEE, TOWARD FRONT, BANK 2 (FRONT SENSOR)
KNOCK SENSOR 2	PI44	2-WAY / BLACK	ENGINE BLOCK, REAR, BANK 1 (REAR SENSOR)
MAF SENSOR	PI14	5-WAY / BLACK	ENGINE AIR INTAKE, ADJACENT TO AIR CLEANER
TMAP SENSOR	PI29	4-WAY / BLACK	INTAKE MANIFOLD, UPPER REAR
THR SENSOR	PI301	4-WAY / BLACK	ENGINE, RH REAR
THROTTLE MOTOR	—	—	THROTTLE BODY
TP SENSOR	—	—	THROTTLE BODY
VVT SOLENOID VALVE 1	PI16	2-WAY / BLACK	RH CYLINDER HEAD, FRONT
VVT SOLENOID VALVE 2	PI17	2-WAY / BLACK	LH CYLINDER HEAD, FRONT

HARNESS IN-LINE CONNECTORS

Connector	Connector Description / Location	Location
FC12	14-WAY / GREY / FASCIA HARNESS TO FRONT HARNESS	BEHIND INSTRUMENT PANEL, PASSENGER SIDE
FC26	16-WAY / BLUE / CABIN HARNESS TO FASCIA HARNESS	BEHIND INSTRUMENT PANEL, DRIVER SIDE
FH1	22-WAY / DARK GREY / CABIN HARNESS TO FRONT HARNESS	RH 'A' POST, LOWER

GROUND S

Ground	Location
FH4 (LHD)	ENGINE COMPARTMENT, BEHIND RH WHEEL ARCH LINER
FH4 (RHD)	ENGINE COMPARTMENT, BEHIND LH WHEEL ARCH LINER

FOR CONTROL MODULE PIN-OUT INFORMATION, UNFOLD PAGE TO LEFT.

Refer to the front of this book for detailed information and illustrations regarding the location and identification of harnesses, relays, fuses, grounds, control modules and control module pins.

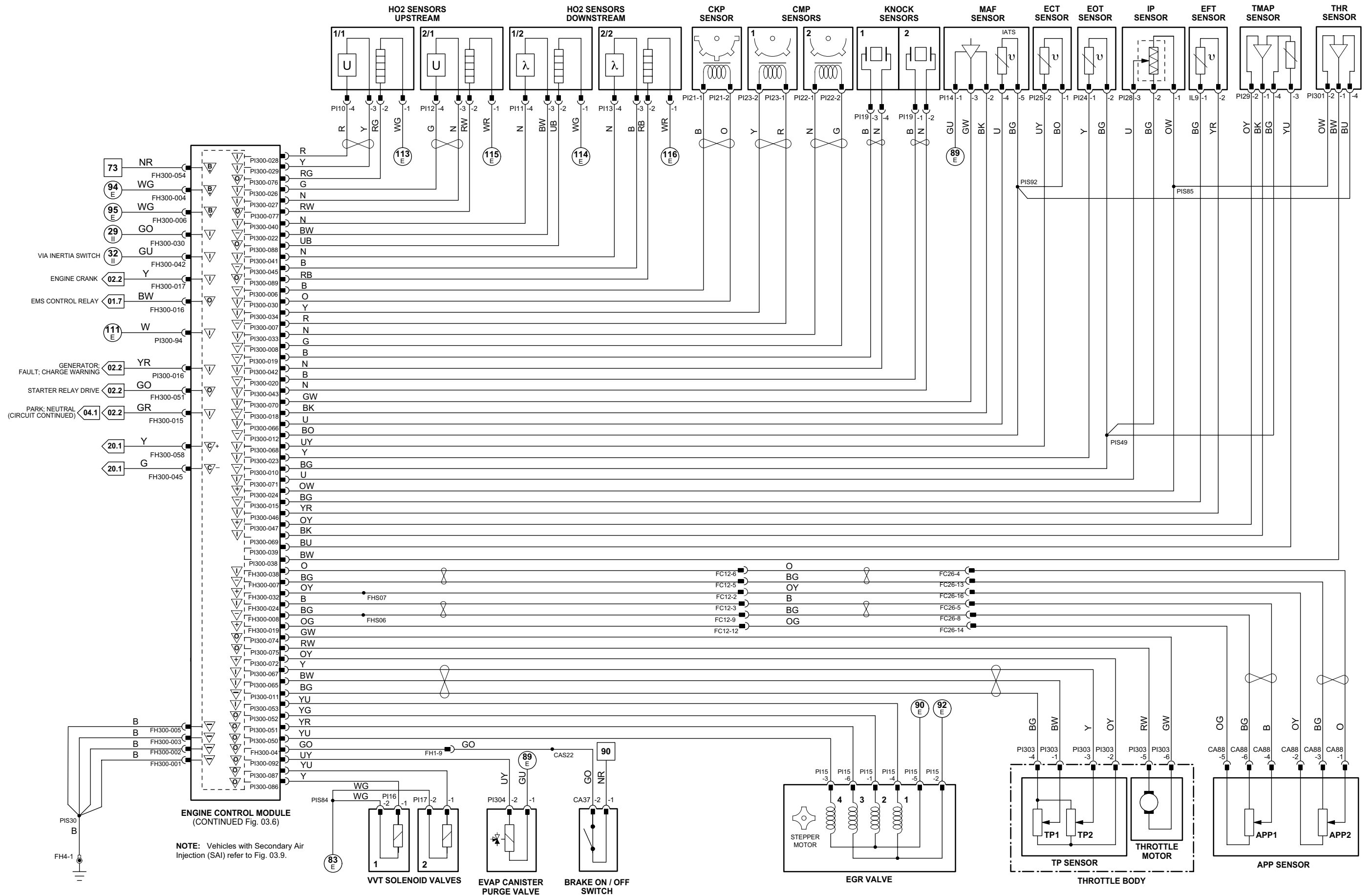

ENGINE CONTROL MODULE (CONTINUED Fig. 03.6)

NOTE: Vehicles with Secondary Air Injection (SAI) refer to Fig. 03.9.

- Fig. 01.1: 1 → 3
- Fig. 01.2: 4 → 76
- Fig. 01.3: 77 → 92
- Fig. 01.4: 1 → 14
- Fig. 01.5: 15 → 45
- Fig. 01.6: 46 → 80
- Fig. 01.7: 81 → 118
- Input: ▽
- Output: ▽
- Battery Voltage: B
- Power Ground: P
- Sensor/Signal Supply V: ▽
- Sensor/Signal Ground: ▽
- CAN: C
- D2B Network: D
- SCP: S
- Serial and Encoded Data: D

VARIANT: V8 SC Vehicles
 VIN RANGE: All
 DATE OF ISSUE: April 2006

Engine Control Module

	Pin	Description and Characteristic
SG	FH300-08	SENSOR GROUND 1: GROUND
I	FH300-12	AIR CONDITIONING PRESSURE SENSOR SIGNAL, NOMINAL 0 – 5 V: TRANSDUCER – VOLTAGE INCREASES AS PRESSURE INCREASES
O	FH300-20	FUEL PUMP DRIVE SIGNAL (TO REM): PWM, 150 Hz, NORMAL POSITIVE DUTY CYCLE RANGE = 4% – 51%
O	FH300-23	LEAK DETECTION HEATER CONTROL
SS	FH300-32	SENSOR POWER SUPPLY 1: NOMINAL 5 V
O	FH300-33	LEAK DETECTION PUMP CONTROL
I	FH300-35	SPEED CONTROL SWITCHES SIGNAL GROUND: GROUND
SS	FH300-36	SPEED CONTROL SWITCH REQUEST: STEPPED RESISTANCE
I	FH300-40	BRAKE CANCEL SWITCH: NORMALLY CLOSED / GROUND WHEN ACTIVATED
I	FH300-43	CLUTCH CANCEL SWITCH: NORMALLY CLOSED / GROUND WHEN ACTIVATED
O	FH300-48	LEAK DETECTION VALVE CONTROL
O	FH300-49	COOLING FAN MODULE CONTROL: PWM, 140 Hz, POSITIVE DUTY CYCLE RANGE 7% – 95%
O	FH300-53	AIR CONDITIONING COMPRESSOR CLUTCH RELAY DRIVE: TO ACTIVATE, ECM SWITCHES CIRCUIT TO GROUND
I	PI300-21	FUEL PUMP MODULE MONITOR: 1 Hz FREQUENCY; 50% DUTY CYCLE = OK, 25% OR 75% DUTY CYCLE = FAULT
O	PI300-49	AIR CLEANER SOLENOID VALVE DRIVE: TO ACTIVATE, ECM SWITCHES CIRCUIT TO GROUND
O	PI300-55	IGNITION COIL ACTIVATE – CYLINDER 7: TO ACTIVATE, ECM SWITCHES CIRCUIT TO GROUND
O	PI300-56	IGNITION COIL ACTIVATE – CYLINDER 6: TO ACTIVATE, ECM SWITCHES CIRCUIT TO GROUND
O	PI300-56	IGNITION COIL ACTIVATE – CYLINDER 8: TO ACTIVATE, ECM SWITCHES CIRCUIT TO GROUND
O	PI300-57	IGNITION COIL ACTIVATE – CYLINDER 5: TO ACTIVATE, ECM SWITCHES CIRCUIT TO GROUND
O	PI300-58	IGNITION COIL ACTIVATE – CYLINDER 4: TO ACTIVATE, ECM SWITCHES CIRCUIT TO GROUND
O	PI300-59	IGNITION COIL ACTIVATE – CYLINDER 3: TO ACTIVATE, ECM SWITCHES CIRCUIT TO GROUND
O	PI300-60	IGNITION COIL ACTIVATE – CYLINDER 2: TO ACTIVATE, ECM SWITCHES CIRCUIT TO GROUND
O	PI300-61	IGNITION COIL ACTIVATE – CYLINDER 1: TO ACTIVATE, ECM SWITCHES CIRCUIT TO GROUND
I	PI300-62	IGNITION MONITOR BANK 1: PULSED SIGNAL, 3 PULSES PER ENGINE CYCLE
I	PI300-64	IGNITION MONITOR BANK 2: PULSED SIGNAL, 3 PULSES PER ENGINE CYCLE
O	PI300-78	FUEL INJECTOR DRIVE – CYLINDER 1: TO ACTIVATE, ECM SWITCHES CIRCUIT TO GROUND
O	PI300-79	FUEL INJECTOR DRIVE – CYLINDER 2: TO ACTIVATE, ECM SWITCHES CIRCUIT TO GROUND
O	PI300-80	FUEL INJECTOR DRIVE – CYLINDER 3: TO ACTIVATE, ECM SWITCHES CIRCUIT TO GROUND
O	PI300-81	FUEL INJECTOR DRIVE – CYLINDER 4: TO ACTIVATE, ECM SWITCHES CIRCUIT TO GROUND
O	PI300-82	FUEL INJECTOR DRIVE – CYLINDER 5: TO ACTIVATE, ECM SWITCHES CIRCUIT TO GROUND
O	PI300-83	FUEL INJECTOR DRIVE – CYLINDER 6: TO ACTIVATE, ECM SWITCHES CIRCUIT TO GROUND
O	PI300-84	FUEL INJECTOR DRIVE – CYLINDER 7: TO ACTIVATE, ECM SWITCHES CIRCUIT TO GROUND
O	PI300-85	FUEL INJECTOR DRIVE – CYLINDER 8: TO ACTIVATE, ECM SWITCHES CIRCUIT TO GROUND

Rear Electronic Module

	Pin	Description and Characteristic
B+	CA100-8	IGNITION SWITCHED POWER SUPPLY (II): B+
B+	CA101-1	FUEL PUMP POWER SUPPLY: B+ WHEN FUEL PUMP RELAY IS ACTIVATED
SG	CA101-2	LOGIC GROUND / FUEL PUMP DRIVE SHIELD: GROUND
B+	CA101-3	BATTERY POWER SUPPLY: B+
S	CA102-1	SCP +
S	CA102-2	SCP –
I	CA103-19	FUEL PUMP DRIVE SIGNAL: PWM, 150 Hz, NORMAL POSITIVE DUTY CYCLE RANGE = 4% – 51%

The following abbreviations are used to represent values for Control Module Pin-Out data

I	Input	PG	Power Ground	C	CAN Network	D	Serial and Encoded Data
O	Output	SS	Sensor / Signal Supply V	S	SCP Network	V	Voltage (DC)
B+	Battery Voltage	SG	Sensor / Signal Ground	D2	D2B Network	PWM	Pulse Width Modulated

CAUTION: The information on this data page is furnished to aid the user in understanding circuit operation. THIS INFORMATION SHOULD BE USED FOR REFERENCE ONLY.

NOTE: The values listed are approximately those that can be expected at the control module connector pins with all circuit connections made and all components connected and fitted.

Fig. 03.6

COMPONENTS

Component	Connector(s)	Connector Description	Location
AIR CLEANER SOLENOID VALVE	FH10	2-WAY / BLACK	AIR CLEANER HOUSING
AIR CONDITIONING COMPRESSOR CLUTCH	PI49	2-WAY / BLACK	LOWER LH SIDE OF ENGINE
AIR CONDITIONING COMPRESSOR CLUTCH RELAY	—	—	FRONT POWER DISTRIBUTION FUSE BOX – R8
AIR CONDITIONING PRESSURE SENSOR	FH110	4-WAY / BLACK	ENGINE COMPARTMENT, LH SIDE, HIGH PRESSURE REFRIGERANT LINE, BETWEEN COMPRESSOR AND CONDENSER TOP OF BRAKE PEDAL
BRAKE CANCEL SWITCH	CA36	2-WAY / GREY	TOP OF BRAKE PEDAL
COOLING FAN MODULE	FH108	2-WAY / BLACK	ENGINE COMPARTMENT, RH FRONT, REARWARD OF RADIATOR
	FH109	2-WAY / BLACK	
ENGINE CONTROL MODULE	FH300	58-WAY / BLACK	FRONT BULKHEAD, PASSENGER SIDE
	PI300	96-WAY / BLACK	
FRONT POWER DISTRIBUTION FUSE BOX	—	—	ENGINE COMPARTMENT, RH SIDE
FUEL INJECTOR 1	PI32	2-WAY / BLACK	FUEL RAIL / INTAKE MANIFOLD
FUEL INJECTOR 2	PI36	2-WAY / BLACK	FUEL RAIL / INTAKE MANIFOLD
FUEL INJECTOR 3	PI33	2-WAY / BLACK	FUEL RAIL / INTAKE MANIFOLD
FUEL INJECTOR 4	PI37	2-WAY / BLACK	FUEL RAIL / INTAKE MANIFOLD
FUEL INJECTOR 5	P34	2-WAY / BLACK	FUEL RAIL / INTAKE MANIFOLD
FUEL INJECTOR 6	PI38	2-WAY / BLACK	FUEL RAIL / INTAKE MANIFOLD
FUEL INJECTOR 7	PI35	2-WAY / BLACK	FUEL RAIL / INTAKE MANIFOLD
FUEL INJECTOR 8	PI39	2-WAY / BLACK	FUEL RAIL / INTAKE MANIFOLD
FUEL PUMP	FP16	6-WAY / BLACK	FUEL TANK, RH SIDE
FUEL PUMP MODULE	FP15	6-WAY / BLACK	ABOVE FUEL TANK
FUEL PUMP RELAY	—	—	REAR POWER DISTRIBUTION FUSE BOX – R15
IGNITION CAPACITOR	PI54	2-WAY / BLACK	LH CYLINDER HEAD, REAR
IGNITION MODULE AND COIL 1	PI2	4-WAY / BLACK	RH CYLINDER HEAD
IGNITION MODULE AND COIL 2	PI6	4-WAY / BLACK	LH CYLINDER HEAD
IGNITION MODULE AND COIL 3	PI3	4-WAY / BLACK	RH CYLINDER HEAD
IGNITION MODULE AND COIL 4	PI7	4-WAY / BLACK	LH CYLINDER HEAD
IGNITION MODULE AND COIL 5	PI4	4-WAY / BLACK	RH CYLINDER HEAD
IGNITION MODULE AND COIL 6	PI8	4-WAY / BLACK	LH CYLINDER HEAD
IGNITION MODULE AND COIL 7	PI5	4-WAY / BLACK	RH CYLINDER HEAD
IGNITION MODULE AND COIL 8	PI9	4-WAY / BLACK	LH CYLINDER HEAD
INTERCOOLER PUMP	CP2	2-WAY / BLACK	ENGINE COMPARTMENT, RH SIDE, ADJACENT TO RADIATOR
LEAK DETECTION UNIT	CA401	4-WAY / BLACK	ABOVE FUEL TANK
REAR ELECTRONIC MODULE	CA63	17-WAY / BLACK	LUGGAGE COMPARTMENT, RH REAR
	CA100	12-WAY / BLACK	
	CA101	20-WAY / BLACK	
	CA102	22-WAY / BLACK	
	CA103	26-WAY / NATURAL	
REAR POWER DISTRIBUTION FUSE BOX	—	—	LUGGAGE COMPARTMENT
STEERING WHEEL SPEED CONTROL SWITCHES	SQ2	6-WAY / BLACK	STEERING WHEEL

HARNESS IN-LINE CONNECTORS

Connector	Connector Description / Location	Location
CP1	10-WAY / BLACK / INTERCOOLER PUMP LINK LEAD	ENGINE COMPARTMENT, RH FRONT, ADJACENT TO RADIATOR
FC10	14-WAY / GREEN / FASCIA HARNESS TO FRONT HARNESS	BEHIND INSTRUMENT PANEL, RH SIDE
FC117	10-WAY / BLACK / STEERING WHEEL CASSETTE	STEERING COLUMN
FH1	22-WAY / DARK GREY / CABIN HARNESS TO FRONT HARNESS	RH 'A' POST, LOWER
FH2	16-WAY / GREY / CABIN HARNESS TO FRONT HARNESS	RH 'A' POST, LOWER
FH3	16-WAY / BLUE / CABIN HARNESS TO FRONT HARNESS	LH 'A' POST
IFP17	3-WAY / BLACK / VEHICLE HARNESS TO FUEL TANK HARNESS	BIW ABOVE FUEL TANK
IS5	6-WAY / BLACK / ENGINE HARNESS TO FUEL INJECTOR LINK	ENGINE, LH REAR
IS6	6-WAY / BLACK / ENGINE HARNESS TO FUEL INJECTOR LINK	ENGINE, RH REAR
PI41	42-WAY / BLACK / ENGINE HARNESS TO VEHICLE HARNESSES	ENGINE COMPARTMENT, BULKHEAD, PASSENGER SIDE

GROUNDS

Ground	Location
CA30	LOWER 'A' POST, LH SIDE
CA50	LOWER 'A' POST, RH SIDE
CA156	LUGGAGE COMPARTMENT, RH SIDE
FH22	ENGINE COMPARTMENT, BEHIND LH HEADLAMP
FH42	ENGINE COMPARTMENT, BEHIND RH HEADLAMP
FH95	ENGINE COMPARTMENT, BEHIND LH HEADLAMP (RADIATOR FAN GROUND)
PI51	ENGINE COMPARTMENT, ENGINE BLOCK

FOR CONTROL MODULE PIN-OUT INFORMATION, UNFOLD PAGE TO LEFT.

Refer to the front of this book for detailed information and illustrations regarding the location and identification of harnesses, relays, fuses, grounds, control modules and control module pins.

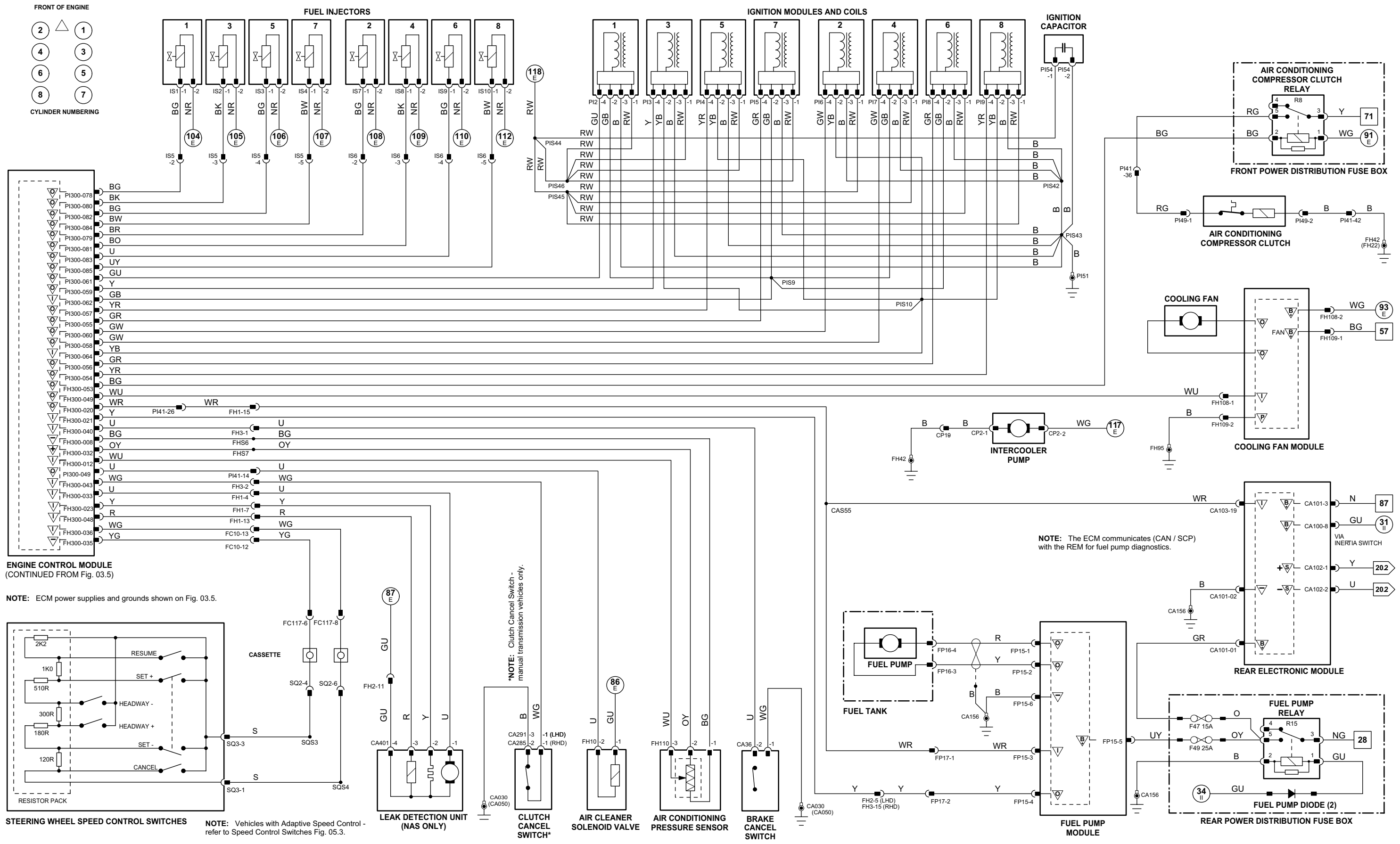

1 → 3	4 → 76	77 → 92	1 → 14	15 → 45	46 → 80	81 → 118	Input	Battery Voltage	Sensor/Signal Supply V	CAN	D2B Network
Fig. 01.1	Fig. 01.2	Fig. 01.3	Fig. 01.4	Fig. 01.5	Fig. 01.6	Fig. 01.7	Output	Power Ground	Sensor/Signal Ground	SCP	Serial and Encoded Data

VARIANT: V8 SC Vehicles
VIN RANGE: All
DATE OF ISSUE: April 2006

Powertrain Control Module

Pin	Description and Characteristic
I C98-A1	EOT SENSOR SIGNAL, NOMINAL 0 – 5 V: NTC SENSOR – VOLTAGE DECREASES AS TEMPERATURE INCREASES
C C98-A3	CAN –
C C98-A4	CAN +
I C98-C4	KNOCK SENSOR 2 SIGNAL: DIFFERENTIAL –ve. VOLTAGE DEPENDENT ON ENGINE VIBRATION
I C98-D1	FRP SENSOR SIGNAL, NOMINAL 0 – 5 V: VOLTAGE INCREASES AS PRESSURE INCREASES
SS C98-D2	FRP SENSOR POWER SUPPLY: NOMINAL 5 V
I C98-D3	KNOCK SENSOR 2 SIGNAL: DIFFERENTIAL +ve. VOLTAGE DEPENDENT ON ENGINE VIBRATION
I C98-D4	KNOCK SENSOR 1 SIGNAL: DIFFERENTIAL –ve. VOLTAGE DEPENDENT ON ENGINE VIBRATION
I C98-E1	EGR THROTTLE POSITION SENSOR SIGNAL: NOMINAL 0 – 5 V
SG C98-E2	FRP SENSOR GROUND: GROUND
I C98-E4	KNOCK SENSOR 1 SIGNAL: DIFFERENTIAL +ve. VOLTAGE DEPENDENT ON ENGINE VIBRATION
SS C98-F1	EGR THROTTLE POSITION SENSOR POWER SUPPLY: NOMINAL 5 V
SG C98-F2	EGR THROTTLE POSITION SENSOR GROUND: GROUND
I C98-F3	INERTIA SWITCH: NORMALLY CLOSED / OPEN CIRCUIT WHEN ACTIVATED
SG C98-K1	EOT SENSOR GROUND (EGR VALVE POSITION SENSOR 1): GROUND
O C98-K4	INLET PORT DEACTIVATION SOLENOID: PWM, 250 Hz
I C99-A2	EGR VALVE POSITION SENSOR 2: NOMINAL 0 – 5 V
I C99-A3	EGR VALVE POSITION SENSOR 1: NOMINAL 0 – 5 V
I C99-B1	ACT SENSOR SIGNAL: NOMINAL 0 – 5 V: NTC SENSOR – VOLTAGE DECREASES AS TEMPERATURE INCREASES
I C99-B2	EFT SENSOR SIGNAL, NOMINAL 0 – 5 V: NTC SENSOR – VOLTAGE DECREASES AS TEMPERATURE INCREASES
O C99-B4	ROTARY ELECTRONIC ACTUATOR 2:
I C99-C1	MAP SENSOR SIGNAL, NOMINAL 0 – 5 V: VOLTAGE INCREASES AS MANIFOLD ABSOLUTE PRESSURE INCREASES
I C99-C2	ECT SENSOR SIGNAL, NOMINAL 0 – 5 V: NTC SENSOR – VOLTAGE DECREASES AS TEMPERATURE INCREASES
SS C99-C3	EGR VALVE POSITION SENSORS POWER SUPPLY: NOMINAL 5 V
O C99-C4	ROTARY ELECTRONIC ACTUATOR 1:
SS C99-D1	MAP SENSOR / ACTUATORS POWER SUPPLY: NOMINAL 5 V
SG C99-D2	EGR VALVE POSITION SENSOR 1 / ACTUATOR 2 GROUND: GROUND
SG* C99-E2	ECT SENSOR GROUND (MAP SENSOR): GROUND
SG* C99-E2	MAP SENSOR GROUND (ECT SENSOR): GROUND
I C99-F1	CKP SENSOR SIGNAL: PULSED SIGNAL, 70 PULSES PER ENGINE CYCLE
I C99-F2	GENERATOR FAULT: CHARGE WARNING
SS C99-G1	CKP SENSOR POWER SUPPLY: NOMINAL 5 V
SG C99-G2	CKP SENSOR SIGNAL GROUND: GROUND
SG* C99-G3	ACT SENSOR GROUND (EGR VALVE 2, EFT SENSOR, ACTUATOR 1): GROUND
SG* C99-G3	EGR VALVE POSITION SENSOR 2 GROUND (ACT SENSOR, EFT SENSOR, ACTUATOR 1): GROUND
SG* C99-G3	EFT SENSOR GROUND (ACT SENSOR, EGR VALVE POSITION SENSOR 2, ACTUATOR 1): GROUND
SG* C99-G3	ACTUATOR 1 GROUND (ACT SENSOR, EGR VALVE POSITION SENSOR 2, EFT SENSOR): GROUND
I C99-G4	CMP SENSOR SIGNAL: PULSED SIGNAL, 4 PULSES PER ENGINE CYCLE
O C99-H1	EGR VALVE 1: +ve PWM
O C99-H2	EGR VALVE 1: –ve PWM
SG C99-H3	CMP SENSOR GROUND: GROUND
SS C99-H4	CMP SENSOR POWER SUPPLY: NOMINAL 5 V
O C99-J1	EGR VALVE 2: +ve PWM
O C99-J2	ROTARY ELECTRONIC ACTUATOR 1:
O C99-J3	ROTARY ELECTRONIC ACTUATOR 2:
O C99-J4	EGR THROTTLE MOTOR DRIVE: +ve PWM
O C99-K1	EGR VALVE 2: –ve PWM
O C99-K2	ROTARY ELECTRONIC ACTUATOR 1:
O C99-K3	ROTARY ELECTRONIC ACTUATOR 2:
O C99-K4	EGR THROTTLE MOTOR DRIVE: –ve PWM
SG FH13-A2	APP SENSOR SHIELD: GROUND
O FH13-B1	STARTER RELAY DRIVE: TO ACTIVATE, PCM SWITCHES CIRCUIT TO GROUND
SG FH13-B2	APP SENSOR 2 GROUND: GROUND
SG FH13-C1	APP SENSOR 1 GROUND: GROUND
I FH13-C2	APP SENSOR 2 SIGNAL: NEGATIVE-GOING VOLTAGE SLOPE, TYPICAL IDLE VOLTAGE = 3.445V TO 3.305V; TYPICAL FULL PEDAL VOLTAGE = 2.05 V
I FH13-D1	APP SENSOR 1 SIGNAL: POSITIVE-GOING VOLTAGE SLOPE, TYPICAL IDLE VOLTAGE = 0.61V TO 0.89V; TYPICAL FULL PEDAL VOLTAGE = 3.4 V
SS FH13-D2	APP SENSOR 2 POWER SUPPLY: NOMINAL 5 V
I FH13-D4	AUTOMATIC – PARK / NEUTRAL SIGNAL: B+ WHEN ACTIVATED
SS FH13-E1	APP SENSOR 1 POWER SUPPLY: NOMINAL 5 V
I FH13-F1	IAT SENSOR (INTEGRAL TO MAF SENSOR) SIGNAL, NOMINAL 0 – 5 V: NTC SENSOR – VOLTAGE DECREASES AS TEMPERATURE INCREASES
I FH13-F3	ENGINE CRANK: B+
I FH13-F4	MAF SENSOR 1 SIGNAL: TIME PERIOD (FREQUENCY) SIGNAL, PROPORTIONAL TO AIR FLOW
I FH13-G2	BRAKE ON / OFF SWITCH: NORMALLY OPEN / B+ WHEN ACTIVATED
I FH13-G4	MAF SENSOR 2 SIGNAL: TIME PERIOD (FREQUENCY) SIGNAL, PROPORTIONAL TO AIR FLOW
O FH13-J3	EMS CONTROL RELAY DRIVE: TO ACTIVATE, PCM SWITCHES CIRCUIT TO GROUND
B+ FH13-K3	IGNITION SWITCHED POWER (RUN): PJB, F4, 5A
B+ FH13-K4	BATTERY POWER SUPPLY: B+
B+ FH13-L1	EMS SWITCHED POWER SUPPLY 1: FPDB, F20, 30A
B+ FH13-L2	EMS SWITCHED POWER SUPPLY 2: FPDB, F20, 30A
B+ FH13-L3	EMS SWITCHED POWER SUPPLY 3: FPDB, F20, 30A
SG FH13-L4	MAF (INTEGRAL IAT) SENSORS GROUND: GROUND
PG FH13-M1	POWER GROUND : GROUND
PG FH13-M2	POWER GROUND : GROUND
PG FH13-M3	POWER GROUND : GROUND
PG FH13-M4	POWER GROUND : GROUND

NOTE: SG* indicates shared-signal grounds, (sharing sensors shown in parentheses).

The following abbreviations are used to represent values for Control Module Pin-Out data

I	Input	PG	Power Ground	C	CAN Network	D	Serial and Encoded Data
O	Output	SS	Sensor / Signal Supply V	S	SCP Network	V	Voltage (DC)
B+	Battery Voltage	SG	Sensor / Signal Ground	D2	D2B Network	PWM	Pulse Width Modulated

CAUTION: The information on this data page is furnished to aid the user in understanding circuit operation. THIS INFORMATION SHOULD BE USED FOR REFERENCE ONLY.

NOTE: The values listed are approximately those that can be expected at the control module connector pins with all circuit connections made and all components connected and fitted.

Fig. 03.7

COMPONENTS

Component	Connector(s)	Connector Description	Location
ACT SENSOR	C69	2-WAY / BLACK	REFER TO SENSORS AND ACTUATORS, PAGE 30 OR 31
APP SENSOR	CA88	6-WAY / BLACK	TOP OF ACCELERATOR PEDAL
BRAKE ON / OFF SWITCH	CA37	2-WAY / BLACK	TOP OF BRAKE PEDAL
CKP SENSOR	C77	3-WAY / BLACK	REFER TO SENSORS AND ACTUATORS, PAGE 30 OR 31
CMP SENSOR	C25	3-WAY / GREY	REFER TO SENSORS AND ACTUATORS, PAGE 30 OR 31
DPF PRESSURE SENSOR	FH311		
ECT SENSOR	C34	2-WAY / GREY	REFER TO SENSORS AND ACTUATORS, PAGE 30 OR 31
EFT SENSOR	C35	2-WAY / BLACK	REFER TO SENSORS AND ACTUATORS, PAGE 30 OR 31
EGR VALVE 1	C70	6-WAY / GREY	REFER TO SENSORS AND ACTUATORS, PAGE 30 OR 31
EGR VALVE 2	C71	6-WAY / GREY	REFER TO SENSORS AND ACTUATORS, PAGE 30 OR 31
EOT SENSOR	C28	3-WAY / BLACK	REFER TO SENSORS AND ACTUATORS, PAGE 30 OR 31
FRP SENSOR	C30	3-WAY / BLACK	REFER TO SENSORS AND ACTUATORS, PAGE 30 OR 31
INLET PORT DEACTIVATION SOLENOID	C36	4-WAY / BLACK	REFER TO SENSORS AND ACTUATORS, PAGE 30 OR 31
KNOCK SENSOR 1	C87	2-WAY / BLACK	REFER TO SENSORS AND ACTUATORS, PAGE 30 OR 31
KNOCK SENSOR 2	C88	2-WAY / BLACK	REFER TO SENSORS AND ACTUATORS, PAGE 30 OR 31
MAF SENSOR 1	FH14	4-WAY / BLACK	REFER TO SENSORS AND ACTUATORS, PAGE 30 OR 31
MAF SENSOR 2	FH15	4-WAY / BLACK	REFER TO SENSORS AND ACTUATORS, PAGE 30 OR 31
MAP SENSOR	C31	3-WAY / BLACK	REFER TO SENSORS AND ACTUATORS, PAGE 30 OR 31
POWERTRAIN CONTROL MODULE	C98	48-WAY / BROWN	FRONT BULKHEAD, PASSENGER SIDE
	C99	48-WAY / GREY	
	FH13	48-WAY / BLACK	
ROTARY ELECTRONIC ACTUATOR 1	C40	5-WAY / BLACK	REFER TO SENSORS AND ACTUATORS, PAGE 30 OR 31
ROTARY ELECTRONIC ACTUATOR 2	C41	5-WAY / BLACK	REFER TO SENSORS AND ACTUATORS, PAGE 30 OR 31
EGR THROTTLE BODY	C39	6-WAY / GREY	REFER TO SENSORS AND ACTUATORS, PAGE 30 OR 31

HARNESS IN-LINE CONNECTORS

Connector	Connector Description / Location	Location
FC12	14-WAY / GREY / FASCIA HARNESS TO FRONT HARNESS	BEHIND INSTRUMENT PANEL, PASSENGER SIDE
FC26	16-WAY / BLUE / CABIN HARNESS TO FASCIA HARNESS	BEHIND INSTRUMENT PANEL, DRIVER SIDE
FH1	22-WAY / DARK GREY / CABIN HARNESS TO FRONT HARNESS	RH 'A' POST, LOWER
PI41	42-WAY / BLACK / ENGINE HARNESS TO VEHICLE HARNESSES	ENGINE COMPARTMENT, BULKHEAD, PASSENGER SIDE

GROUNDS

Ground	Location
FH4	ENGINE COMPARTMENT, REARWARD OF RH WHEEL ARCH

FOR CONTROL MODULE PIN-OUT INFORMATION, UNFOLD PAGE TO LEFT.

Refer to the front of this book for detailed information and illustrations regarding the location and identification of harnesses, relays, fuses, grounds, control modules and control module pins.

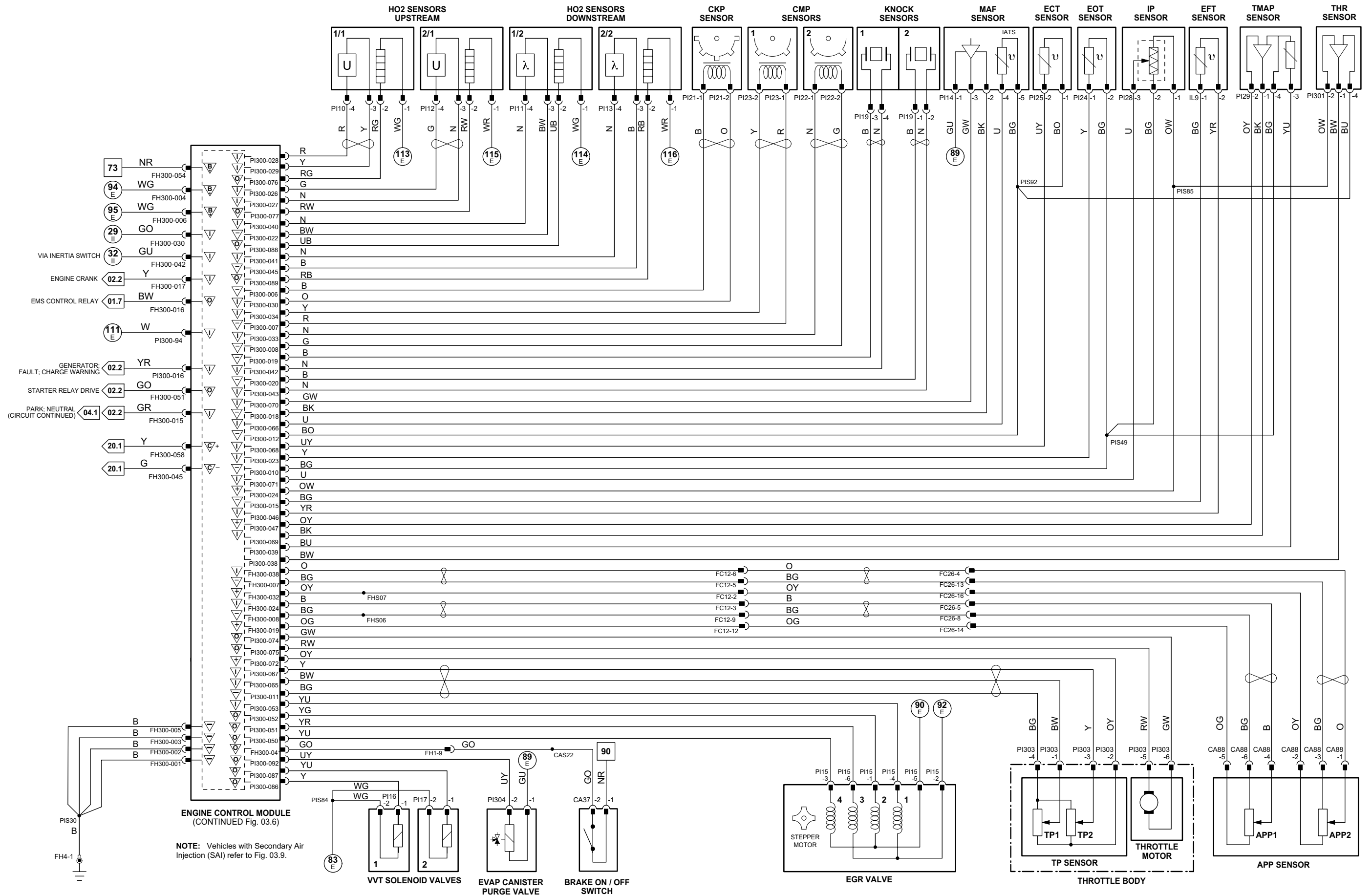

ENGINE CONTROL MODULE (CONTINUED Fig. 03.6)

NOTE: Vehicles with Secondary Air Injection (SAI) refer to Fig. 03.9.

- Fig. 01.1: 1 → 3
- Fig. 01.2: 4 → 76
- Fig. 01.3: 77 → 92
- Fig. 01.4: 1 → 14
- Fig. 01.5: 15 → 45
- Fig. 01.6: 46 → 80
- Fig. 01.7: 81 → 118
- Input: ▽
- Output: ▽
- Battery Voltage: B
- Power Ground: P
- Sensor/Signal Supply V: ▽
- Sensor/Signal Ground: ▽
- CAN: C
- D2B Network: D
- SCP: S
- Serial and Encoded Data: D

VARIANT: V8 SC Vehicles
 VIN RANGE: All
 DATE OF ISSUE: April 2006

Engine Control Module

	Pin	Description and Characteristic
SG	FH300-08	SENSOR GROUND 1: GROUND
I	FH300-12	AIR CONDITIONING PRESSURE SENSOR SIGNAL, NOMINAL 0 – 5 V; TRANSDUCER – VOLTAGE INCREASES AS PRESSURE INCREASES
O	FH300-20	FUEL PUMP DRIVE SIGNAL (TO REM): PWM, 150 Hz, NORMAL POSITIVE DUTY CYCLE RANGE = 4% – 51%
O	FH300-23	LEAK DETECTION HEATER CONTROL
SS	FH300-32	SENSOR POWER SUPPLY 1: NOMINAL 5 V
O	FH300-33	LEAK DETECTION PUMP CONTROL
I	FH300-35	SPEED CONTROL SWITCHES SIGNAL GROUND: GROUND
SS	FH300-36	SPEED CONTROL SWITCH REQUEST: STEPPED RESISTANCE
I	FH300-40	BRAKE CANCEL SWITCH: NORMALLY CLOSED / GROUND WHEN ACTIVATED
I	FH300-43	CLUTCH CANCEL SWITCH: NORMALLY CLOSED / GROUND WHEN ACTIVATED
O	FH300-48	LEAK DETECTION VALVE CONTROL
O	FH300-49	COOLING FAN MODULE CONTROL: PWM, 140 Hz, POSITIVE DUTY CYCLE RANGE 7% – 95%
O	FH300-53	AIR CONDITIONING COMPRESSOR CLUTCH RELAY DRIVE: TO ACTIVATE, ECM SWITCHES CIRCUIT TO GROUND
I	P1300-21	FUEL PUMP MODULE MONITOR: 1 Hz FREQUENCY; 50% DUTY CYCLE = OK, 25% OR 75% DUTY CYCLE = FAULT
O	P1300-49	AIR CLEANER SOLENOID VALVE DRIVE: TO ACTIVATE, ECM SWITCHES CIRCUIT TO GROUND
O	P1300-55	IGNITION COIL ACTIVATE – CYLINDER 7: TO ACTIVATE, ECM SWITCHES CIRCUIT TO GROUND
O	P1300-56	IGNITION COIL ACTIVATE – CYLINDER 6: TO ACTIVATE, ECM SWITCHES CIRCUIT TO GROUND
O	P1300-56	IGNITION COIL ACTIVATE – CYLINDER 8: TO ACTIVATE, ECM SWITCHES CIRCUIT TO GROUND
O	P1300-57	IGNITION COIL ACTIVATE – CYLINDER 5: TO ACTIVATE, ECM SWITCHES CIRCUIT TO GROUND
O	P1300-58	IGNITION COIL ACTIVATE – CYLINDER 4: TO ACTIVATE, ECM SWITCHES CIRCUIT TO GROUND
O	P1300-59	IGNITION COIL ACTIVATE – CYLINDER 3: TO ACTIVATE, ECM SWITCHES CIRCUIT TO GROUND
O	P1300-60	IGNITION COIL ACTIVATE – CYLINDER 2: TO ACTIVATE, ECM SWITCHES CIRCUIT TO GROUND
O	P1300-61	IGNITION COIL ACTIVATE – CYLINDER 1: TO ACTIVATE, ECM SWITCHES CIRCUIT TO GROUND
I	P1300-62	IGNITION MONITOR BANK 1: PULSED SIGNAL, 3 PULSES PER ENGINE CYCLE
I	P1300-64	IGNITION MONITOR BANK 2: PULSED SIGNAL, 3 PULSES PER ENGINE CYCLE
O	P1300-78	FUEL INJECTOR DRIVE – CYLINDER 1: TO ACTIVATE, ECM SWITCHES CIRCUIT TO GROUND
O	P1300-79	FUEL INJECTOR DRIVE – CYLINDER 2: TO ACTIVATE, ECM SWITCHES CIRCUIT TO GROUND
O	P1300-80	FUEL INJECTOR DRIVE – CYLINDER 3: TO ACTIVATE, ECM SWITCHES CIRCUIT TO GROUND
O	P1300-81	FUEL INJECTOR DRIVE – CYLINDER 4: TO ACTIVATE, ECM SWITCHES CIRCUIT TO GROUND
O	P1300-82	FUEL INJECTOR DRIVE – CYLINDER 5: TO ACTIVATE, ECM SWITCHES CIRCUIT TO GROUND
O	P1300-83	FUEL INJECTOR DRIVE – CYLINDER 6: TO ACTIVATE, ECM SWITCHES CIRCUIT TO GROUND
O	P1300-84	FUEL INJECTOR DRIVE – CYLINDER 7: TO ACTIVATE, ECM SWITCHES CIRCUIT TO GROUND
O	P1300-85	FUEL INJECTOR DRIVE – CYLINDER 8: TO ACTIVATE, ECM SWITCHES CIRCUIT TO GROUND

Rear Electronic Module

	Pin	Description and Characteristic
B+	CA100-8	IGNITION SWITCHED POWER SUPPLY (II): B+
B+	CA101-1	FUEL PUMP POWER SUPPLY: B+ WHEN FUEL PUMP RELAY IS ACTIVATED
SG	CA101-2	LOGIC GROUND / FUEL PUMP DRIVE SHIELD: GROUND
B+	CA101-3	BATTERY POWER SUPPLY: B+
S	CA102-1	SCP +
S	CA102-2	SCP –
I	CA103-19	FUEL PUMP DRIVE SIGNAL: PWM, 150 Hz, NORMAL POSITIVE DUTY CYCLE RANGE = 4% – 51%

The following abbreviations are used to represent values for Control Module Pin-Out data

I	Input	PG	Power Ground	C	CAN Network	D	Serial and Encoded Data
O	Output	SS	Sensor / Signal Supply V	S	SCP Network	V	Voltage (DC)
B+	Battery Voltage	SG	Sensor / Signal Ground	D2	D2B Network	PWM	Pulse Width Modulated

CAUTION: The information on this data page is furnished to aid the user in understanding circuit operation. THIS INFORMATION SHOULD BE USED FOR REFERENCE ONLY.

NOTE: The values listed are approximately those that can be expected at the control module connector pins with all circuit connections made and all components connected and fitted.

Fig. 03.6

COMPONENTS

Component	Connector(s)	Connector Description	Location
AIR CLEANER SOLENOID VALVE	FH10	2-WAY / BLACK	AIR CLEANER HOUSING
AIR CONDITIONING COMPRESSOR CLUTCH	PI49	2-WAY / BLACK	LOWER LH SIDE OF ENGINE
AIR CONDITIONING COMPRESSOR CLUTCH RELAY	—	—	FRONT POWER DISTRIBUTION FUSE BOX – R8
AIR CONDITIONING PRESSURE SENSOR	FH110	4-WAY / BLACK	ENGINE COMPARTMENT, LH SIDE, HIGH PRESSURE REFRIGERANT LINE, BETWEEN COMPRESSOR AND CONDENSER TOP OF BRAKE PEDAL
BRAKE CANCEL SWITCH	CA36	2-WAY / GREY	TOP OF BRAKE PEDAL
COOLING FAN MODULE	FH108	2-WAY / BLACK	ENGINE COMPARTMENT, RH FRONT, REARWARD OF RADIATOR
	FH109	2-WAY / BLACK	
ENGINE CONTROL MODULE	FH300	58-WAY / BLACK	FRONT BULKHEAD, PASSENGER SIDE
	PI300	96-WAY / BLACK	
FRONT POWER DISTRIBUTION FUSE BOX	—	—	ENGINE COMPARTMENT, RH SIDE
FUEL INJECTOR 1	PI32	2-WAY / BLACK	FUEL RAIL / INTAKE MANIFOLD
FUEL INJECTOR 2	PI36	2-WAY / BLACK	FUEL RAIL / INTAKE MANIFOLD
FUEL INJECTOR 3	PI33	2-WAY / BLACK	FUEL RAIL / INTAKE MANIFOLD
FUEL INJECTOR 4	PI37	2-WAY / BLACK	FUEL RAIL / INTAKE MANIFOLD
FUEL INJECTOR 5	P34	2-WAY / BLACK	FUEL RAIL / INTAKE MANIFOLD
FUEL INJECTOR 6	PI38	2-WAY / BLACK	FUEL RAIL / INTAKE MANIFOLD
FUEL INJECTOR 7	PI35	2-WAY / BLACK	FUEL RAIL / INTAKE MANIFOLD
FUEL INJECTOR 8	PI39	2-WAY / BLACK	FUEL RAIL / INTAKE MANIFOLD
FUEL PUMP	FP16	6-WAY / BLACK	FUEL TANK, RH SIDE
FUEL PUMP MODULE	FP15	6-WAY / BLACK	ABOVE FUEL TANK
FUEL PUMP RELAY	—	—	REAR POWER DISTRIBUTION FUSE BOX – R15
IGNITION CAPACITOR	PI54	2-WAY / BLACK	LH CYLINDER HEAD, REAR
IGNITION MODULE AND COIL 1	PI2	4-WAY / BLACK	RH CYLINDER HEAD
IGNITION MODULE AND COIL 2	PI6	4-WAY / BLACK	LH CYLINDER HEAD
IGNITION MODULE AND COIL 3	PI3	4-WAY / BLACK	RH CYLINDER HEAD
IGNITION MODULE AND COIL 4	PI7	4-WAY / BLACK	LH CYLINDER HEAD
IGNITION MODULE AND COIL 5	PI4	4-WAY / BLACK	RH CYLINDER HEAD
IGNITION MODULE AND COIL 6	PI8	4-WAY / BLACK	LH CYLINDER HEAD
IGNITION MODULE AND COIL 7	PI5	4-WAY / BLACK	RH CYLINDER HEAD
IGNITION MODULE AND COIL 8	PI9	4-WAY / BLACK	LH CYLINDER HEAD
INTERCOOLER PUMP	CP2	2-WAY / BLACK	ENGINE COMPARTMENT, RH SIDE, ADJACENT TO RADIATOR
LEAK DETECTION UNIT	CA401	4-WAY / BLACK	ABOVE FUEL TANK
REAR ELECTRONIC MODULE	CA63	17-WAY / BLACK	LUGGAGE COMPARTMENT, RH REAR
	CA100	12-WAY / BLACK	
	CA101	20-WAY / BLACK	
	CA102	22-WAY / BLACK	
	CA103	26-WAY / NATURAL	
REAR POWER DISTRIBUTION FUSE BOX	—	—	LUGGAGE COMPARTMENT
STEERING WHEEL SPEED CONTROL SWITCHES	SQ2	6-WAY / BLACK	STEERING WHEEL

HARNESS IN-LINE CONNECTORS

Connector	Connector Description / Location	Location
CP1	10-WAY / BLACK / INTERCOOLER PUMP LINK LEAD	ENGINE COMPARTMENT, RH FRONT, ADJACENT TO RADIATOR
FC10	14-WAY / GREEN / FASCIA HARNESS TO FRONT HARNESS	BEHIND INSTRUMENT PANEL, RH SIDE
FC117	10-WAY / BLACK / STEERING WHEEL CASSETTE	STEERING COLUMN
FH1	22-WAY / DARK GREY / CABIN HARNESS TO FRONT HARNESS	RH 'A' POST, LOWER
FH2	16-WAY / GREY / CABIN HARNESS TO FRONT HARNESS	RH 'A' POST, LOWER
FH3	16-WAY / BLUE / CABIN HARNESS TO FRONT HARNESS	LH 'A' POST
IFP17	3-WAY / BLACK / VEHICLE HARNESS TO FUEL TANK HARNESS	BIW ABOVE FUEL TANK
IS5	6-WAY / BLACK / ENGINE HARNESS TO FUEL INJECTOR LINK	ENGINE, LH REAR
IS6	6-WAY / BLACK / ENGINE HARNESS TO FUEL INJECTOR LINK	ENGINE, RH REAR
PI41	42-WAY / BLACK / ENGINE HARNESS TO VEHICLE HARNESSES	ENGINE COMPARTMENT, BULKHEAD, PASSENGER SIDE

GROUNDS

Ground	Location
CA30	LOWER 'A' POST, LH SIDE
CA50	LOWER 'A' POST, RH SIDE
CA156	LUGGAGE COMPARTMENT, RH SIDE
FH22	ENGINE COMPARTMENT, BEHIND LH HEADLAMP
FH42	ENGINE COMPARTMENT, BEHIND RH HEADLAMP
FH95	ENGINE COMPARTMENT, BEHIND LH HEADLAMP (RADIATOR FAN GROUND)
PI51	ENGINE COMPARTMENT, ENGINE BLOCK

FOR CONTROL MODULE PIN-OUT INFORMATION, UNFOLD PAGE TO LEFT.

Refer to the front of this book for detailed information and illustrations regarding the location and identification of harnesses, relays, fuses, grounds, control modules and control module pins.

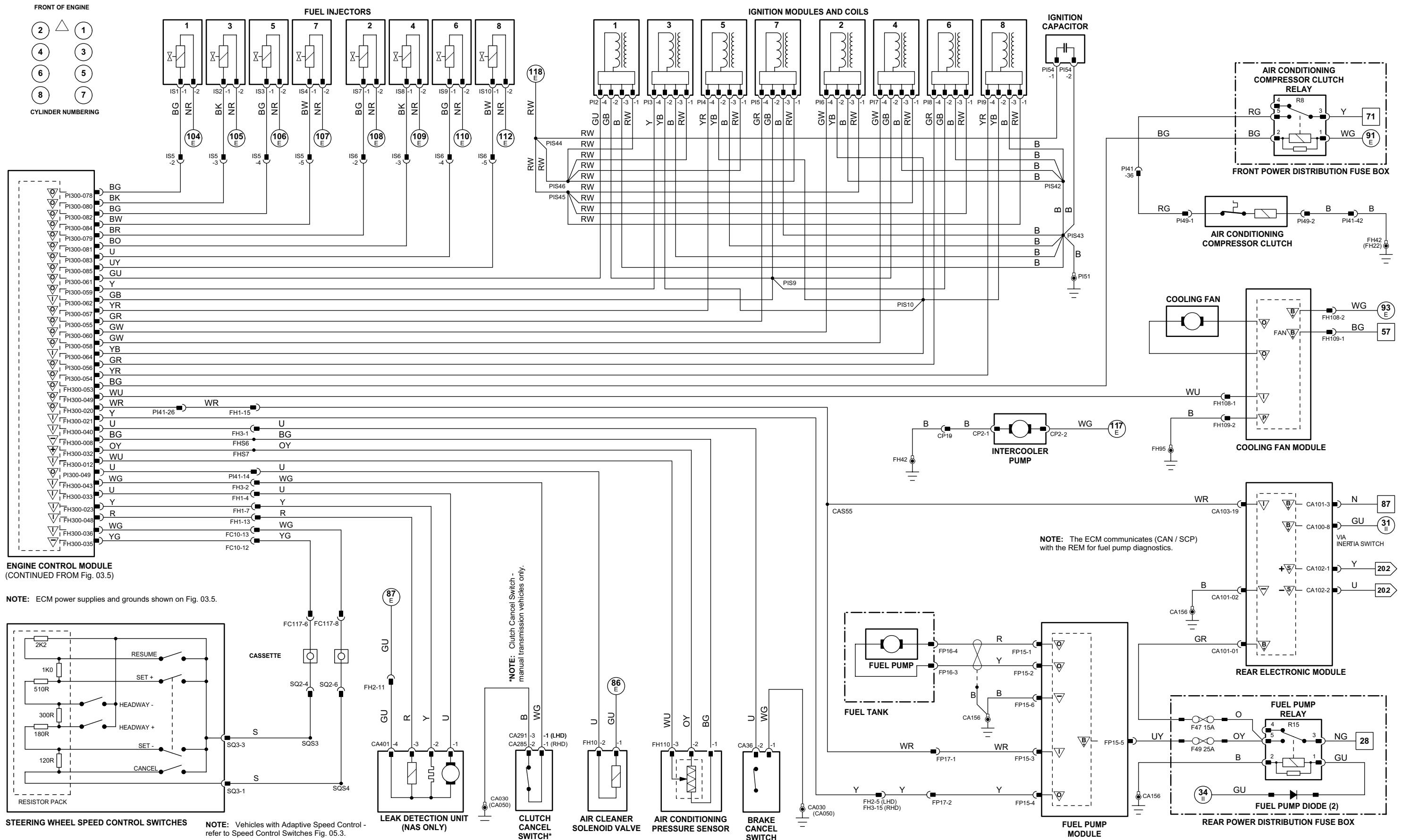

1 → 3	4 → 76	77 → 92	1 → 14	15 → 45	46 → 80	81 → 118	Input	Battery Voltage	Sensor/Signal Supply V	CAN	D2B Network
Fig. 01.1	Fig. 01.2	Fig. 01.3	Fig. 01.4	Fig. 01.5	Fig. 01.6	Fig. 01.7	Output	Power Ground	Sensor/Signal Ground	SCP	Serial and Encoded Data

VARIANT: V8 SC Vehicles
VIN RANGE: All
DATE OF ISSUE: April 2006

Powertrain Control Module

Pin	Description and Characteristic
I C98-A1	EOT SENSOR SIGNAL, NOMINAL 0 – 5 V: NTC SENSOR – VOLTAGE DECREASES AS TEMPERATURE INCREASES
C C98-A3	CAN –
C C98-A4	CAN +
I C98-C4	KNOCK SENSOR 2 SIGNAL: DIFFERENTIAL –ve. VOLTAGE DEPENDENT ON ENGINE VIBRATION
I C98-D1	FRP SENSOR SIGNAL, NOMINAL 0 – 5 V: VOLTAGE INCREASES AS PRESSURE INCREASES
SS C98-D2	FRP SENSOR POWER SUPPLY: NOMINAL 5 V
I C98-D3	KNOCK SENSOR 2 SIGNAL: DIFFERENTIAL +ve. VOLTAGE DEPENDENT ON ENGINE VIBRATION
I C98-D4	KNOCK SENSOR 1 SIGNAL: DIFFERENTIAL –ve. VOLTAGE DEPENDENT ON ENGINE VIBRATION
I C98-E1	EGR THROTTLE POSITION SENSOR SIGNAL: NOMINAL 0 – 5 V
SG C98-E2	FRP SENSOR GROUND: GROUND
I C98-E4	KNOCK SENSOR 1 SIGNAL: DIFFERENTIAL +ve. VOLTAGE DEPENDENT ON ENGINE VIBRATION
SS C98-F1	EGR THROTTLE POSITION SENSOR POWER SUPPLY: NOMINAL 5 V
SG C98-F2	EGR THROTTLE POSITION SENSOR GROUND: GROUND
I C98-F3	INERTIA SWITCH: NORMALLY CLOSED / OPEN CIRCUIT WHEN ACTIVATED
SG C98-K1	EOT SENSOR GROUND (EGR VALVE POSITION SENSOR 1): GROUND
O C98-K4	INLET PORT DEACTIVATION SOLENOID: PWM, 250 Hz
I C99-A2	EGR VALVE POSITION SENSOR 2: NOMINAL 0 – 5 V
I C99-A3	EGR VALVE POSITION SENSOR 1: NOMINAL 0 – 5 V
I C99-B1	ACT SENSOR SIGNAL: NOMINAL 0 – 5 V: NTC SENSOR – VOLTAGE DECREASES AS TEMPERATURE INCREASES
I C99-B2	EFT SENSOR SIGNAL, NOMINAL 0 – 5 V: NTC SENSOR – VOLTAGE DECREASES AS TEMPERATURE INCREASES
O C99-B4	ROTARY ELECTRONIC ACTUATOR 2:
I C99-C1	MAP SENSOR SIGNAL, NOMINAL 0 – 5 V: VOLTAGE INCREASES AS MANIFOLD ABSOLUTE PRESSURE INCREASES
I C99-C2	ECT SENSOR SIGNAL, NOMINAL 0 – 5 V: NTC SENSOR – VOLTAGE DECREASES AS TEMPERATURE INCREASES
SS C99-C3	EGR VALVE POSITION SENSORS POWER SUPPLY: NOMINAL 5 V
O C99-C4	ROTARY ELECTRONIC ACTUATOR 1:
SS C99-D1	MAP SENSOR / ACTUATORS POWER SUPPLY: NOMINAL 5 V
SG C99-D2	EGR VALVE POSITION SENSOR 1 / ACTUATOR 2 GROUND: GROUND
SG* C99-E2	ECT SENSOR GROUND (MAP SENSOR): GROUND
SG* C99-E2	MAP SENSOR GROUND (ECT SENSOR): GROUND
I C99-F1	CKP SENSOR SIGNAL: PULSED SIGNAL, 70 PULSES PER ENGINE CYCLE
I C99-F2	GENERATOR FAULT: CHARGE WARNING
SS C99-G1	CKP SENSOR POWER SUPPLY: NOMINAL 5 V
SG C99-G2	CKP SENSOR SIGNAL GROUND: GROUND
SG* C99-G3	ACT SENSOR GROUND (EGR VALVE 2, EFT SENSOR, ACTUATOR 1): GROUND
SG* C99-G3	EGR VALVE POSITION SENSOR 2 GROUND (ACT SENSOR, EFT SENSOR, ACTUATOR 1): GROUND
SG* C99-G3	EFT SENSOR GROUND (ACT SENSOR, EGR VALVE POSITION SENSOR 2, ACTUATOR 1): GROUND
SG* C99-G3	ACTUATOR 1 GROUND (ACT SENSOR, EGR VALVE POSITION SENSOR 2, EFT SENSOR): GROUND
I C99-G4	CMP SENSOR SIGNAL: PULSED SIGNAL, 4 PULSES PER ENGINE CYCLE
O C99-H1	EGR VALVE 1: +ve PWM
O C99-H2	EGR VALVE 1: –ve PWM
SG C99-H3	CMP SENSOR GROUND: GROUND
SS C99-H4	CMP SENSOR POWER SUPPLY: NOMINAL 5 V
O C99-J1	EGR VALVE 2: +ve PWM
O C99-J2	ROTARY ELECTRONIC ACTUATOR 1:
O C99-J3	ROTARY ELECTRONIC ACTUATOR 2:
O C99-J4	EGR THROTTLE MOTOR DRIVE: +ve PWM
O C99-K1	EGR VALVE 2: –ve PWM
O C99-K2	ROTARY ELECTRONIC ACTUATOR 1:
O C99-K3	ROTARY ELECTRONIC ACTUATOR 2:
O C99-K4	EGR THROTTLE MOTOR DRIVE: –ve PWM
SG FH13-A2	APP SENSOR SHIELD: GROUND
O FH13-B1	STARTER RELAY DRIVE: TO ACTIVATE, PCM SWITCHES CIRCUIT TO GROUND
SG FH13-B2	APP SENSOR 2 GROUND: GROUND
SG FH13-C1	APP SENSOR 1 GROUND: GROUND
I FH13-C2	APP SENSOR 2 SIGNAL: NEGATIVE-GOING VOLTAGE SLOPE, TYPICAL IDLE VOLTAGE = 3.445V TO 3.305V; TYPICAL FULL PEDAL VOLTAGE = 2.05 V
I FH13-D1	APP SENSOR 1 SIGNAL: POSITIVE-GOING VOLTAGE SLOPE, TYPICAL IDLE VOLTAGE = 0.61V TO 0.89V; TYPICAL FULL PEDAL VOLTAGE = 3.4 V
SS FH13-D2	APP SENSOR 2 POWER SUPPLY: NOMINAL 5 V
I FH13-D4	AUTOMATIC – PARK / NEUTRAL SIGNAL: B+ WHEN ACTIVATED
SS FH13-E1	APP SENSOR 1 POWER SUPPLY: NOMINAL 5 V
I FH13-F1	IAT SENSOR (INTEGRAL TO MAF SENSOR) SIGNAL, NOMINAL 0 – 5 V: NTC SENSOR – VOLTAGE DECREASES AS TEMPERATURE INCREASES
I FH13-F3	ENGINE CRANK: B+
I FH13-F4	MAF SENSOR 1 SIGNAL: TIME PERIOD (FREQUENCY) SIGNAL, PROPORTIONAL TO AIR FLOW
I FH13-G2	BRAKE ON / OFF SWITCH: NORMALLY OPEN / B+ WHEN ACTIVATED
I FH13-G4	MAF SENSOR 2 SIGNAL: TIME PERIOD (FREQUENCY) SIGNAL, PROPORTIONAL TO AIR FLOW
O FH13-J3	EMS CONTROL RELAY DRIVE: TO ACTIVATE, PCM SWITCHES CIRCUIT TO GROUND
B+ FH13-K3	IGNITION SWITCHED POWER (RUN): PJB, F4, 5A
B+ FH13-K4	BATTERY POWER SUPPLY: B+
B+ FH13-L1	EMS SWITCHED POWER SUPPLY 1: FPDB, F20, 30A
B+ FH13-L2	EMS SWITCHED POWER SUPPLY 2: FPDB, F20, 30A
B+ FH13-L3	EMS SWITCHED POWER SUPPLY 3: FPDB, F20, 30A
SG FH13-L4	MAF (INTEGRAL IAT) SENSORS GROUND: GROUND
PG FH13-M1	POWER GROUND : GROUND
PG FH13-M2	POWER GROUND : GROUND
PG FH13-M3	POWER GROUND : GROUND
PG FH13-M4	POWER GROUND : GROUND

NOTE: SG* indicates shared-signal grounds, (sharing sensors shown in parentheses).

The following abbreviations are used to represent values for Control Module Pin-Out data

I	Input	PG	Power Ground	C	CAN Network	D	Serial and Encoded Data
O	Output	SS	Sensor / Signal Supply V	S	SCP Network	V	Voltage (DC)
B+	Battery Voltage	SG	Sensor / Signal Ground	D2	D2B Network	PWM	Pulse Width Modulated

CAUTION: The information on this data page is furnished to aid the user in understanding circuit operation. THIS INFORMATION SHOULD BE USED FOR REFERENCE ONLY.

NOTE: The values listed are approximately those that can be expected at the control module connector pins with all circuit connections made and all components connected and fitted.

Fig. 03.7

COMPONENTS

Component	Connector(s)	Connector Description	Location
ACT SENSOR	C69	2-WAY / BLACK	REFER TO SENSORS AND ACTUATORS, PAGE 30 OR 31
APP SENSOR	CA88	6-WAY / BLACK	TOP OF ACCELERATOR PEDAL
BRAKE ON / OFF SWITCH	CA37	2-WAY / BLACK	TOP OF BRAKE PEDAL
CKP SENSOR	C77	3-WAY / BLACK	REFER TO SENSORS AND ACTUATORS, PAGE 30 OR 31
CMP SENSOR	C25	3-WAY / GREY	REFER TO SENSORS AND ACTUATORS, PAGE 30 OR 31
DPF PRESSURE SENSOR	FH311		
ECT SENSOR	C34	2-WAY / GREY	REFER TO SENSORS AND ACTUATORS, PAGE 30 OR 31
EFT SENSOR	C35	2-WAY / BLACK	REFER TO SENSORS AND ACTUATORS, PAGE 30 OR 31
EGR VALVE 1	C70	6-WAY / GREY	REFER TO SENSORS AND ACTUATORS, PAGE 30 OR 31
EGR VALVE 2	C71	6-WAY / GREY	REFER TO SENSORS AND ACTUATORS, PAGE 30 OR 31
EOT SENSOR	C28	3-WAY / BLACK	REFER TO SENSORS AND ACTUATORS, PAGE 30 OR 31
FRP SENSOR	C30	3-WAY / BLACK	REFER TO SENSORS AND ACTUATORS, PAGE 30 OR 31
INLET PORT DEACTIVATION SOLENOID	C36	4-WAY / BLACK	REFER TO SENSORS AND ACTUATORS, PAGE 30 OR 31
KNOCK SENSOR 1	C87	2-WAY / BLACK	REFER TO SENSORS AND ACTUATORS, PAGE 30 OR 31
KNOCK SENSOR 2	C88	2-WAY / BLACK	REFER TO SENSORS AND ACTUATORS, PAGE 30 OR 31
MAF SENSOR 1	FH14	4-WAY / BLACK	REFER TO SENSORS AND ACTUATORS, PAGE 30 OR 31
MAF SENSOR 2	FH15	4-WAY / BLACK	REFER TO SENSORS AND ACTUATORS, PAGE 30 OR 31
MAP SENSOR	C31	3-WAY / BLACK	REFER TO SENSORS AND ACTUATORS, PAGE 30 OR 31
POWERTRAIN CONTROL MODULE	C98	48-WAY / BROWN	FRONT BULKHEAD, PASSENGER SIDE
	C99	48-WAY / GREY	
	FH13	48-WAY / BLACK	
ROTARY ELECTRONIC ACTUATOR 1	C40	5-WAY / BLACK	REFER TO SENSORS AND ACTUATORS, PAGE 30 OR 31
ROTARY ELECTRONIC ACTUATOR 2	C41	5-WAY / BLACK	REFER TO SENSORS AND ACTUATORS, PAGE 30 OR 31
EGR THROTTLE BODY	C39	6-WAY / GREY	REFER TO SENSORS AND ACTUATORS, PAGE 30 OR 31

HARNESS IN-LINE CONNECTORS

Connector	Connector Description / Location	Location
FC12	14-WAY / GREY / FASCIA HARNESS TO FRONT HARNESS	BEHIND INSTRUMENT PANEL, PASSENGER SIDE
FC26	16-WAY / BLUE / CABIN HARNESS TO FASCIA HARNESS	BEHIND INSTRUMENT PANEL, DRIVER SIDE
FH1	22-WAY / DARK GREY / CABIN HARNESS TO FRONT HARNESS	RH 'A' POST, LOWER
PI41	42-WAY / BLACK / ENGINE HARNESS TO VEHICLE HARNESSES	ENGINE COMPARTMENT, BULKHEAD, PASSENGER SIDE

GROUNDS

Ground	Location
FH4	ENGINE COMPARTMENT, REARWARD OF RH WHEEL ARCH

FOR CONTROL MODULE PIN-OUT INFORMATION, UNFOLD PAGE TO LEFT.

Refer to the front of this book for detailed information and illustrations regarding the location and identification of harnesses, relays, fuses, grounds, control modules and control module pins.

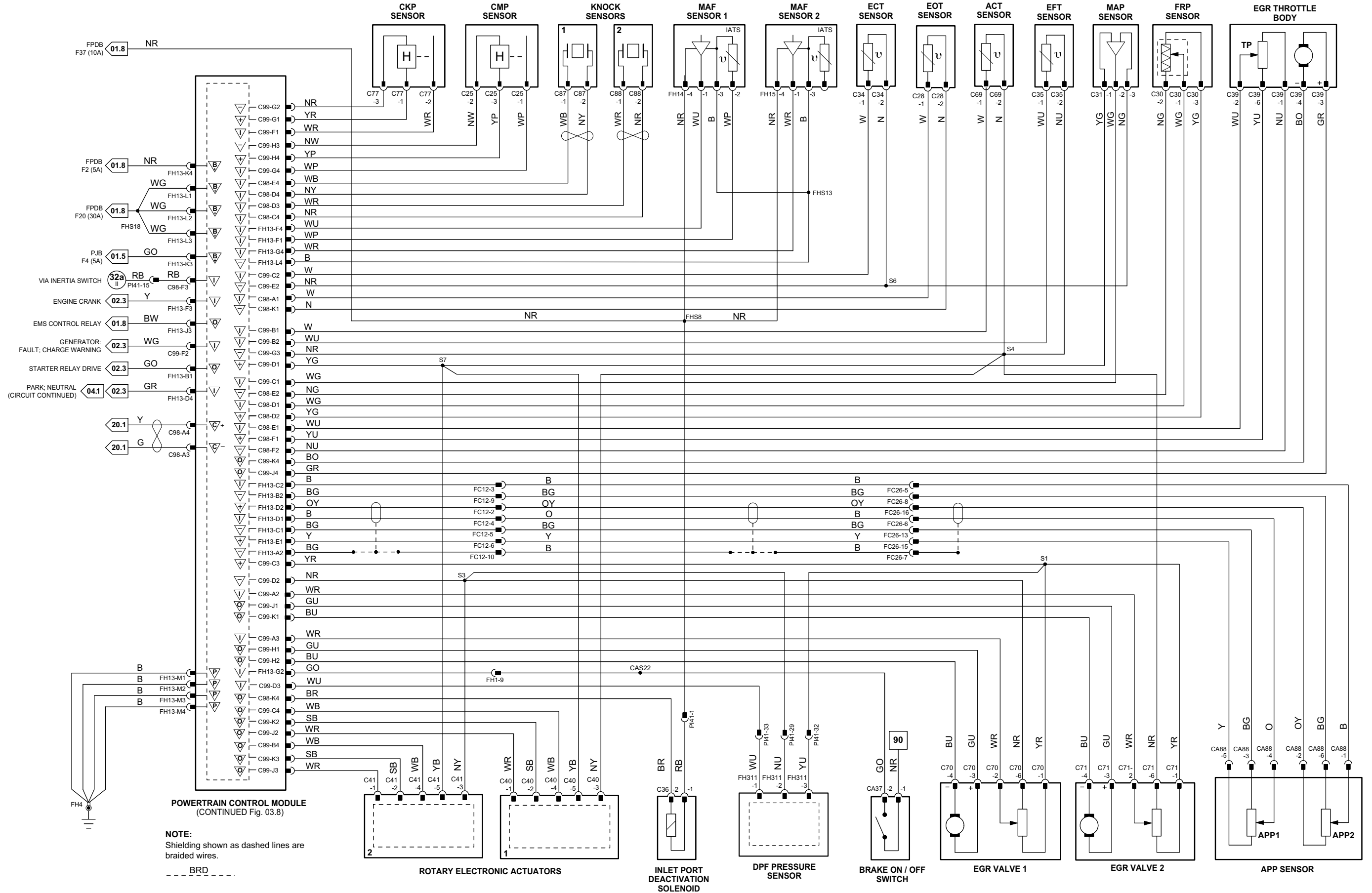

Powertrain Control Module

	Pin	Description and Characteristic
SS	C98-B1	CATALYTIC CONVERTER TEMPERATURE SENSOR - BANK 1 UPSTREAM SIGNAL:
I	C98-E3	GLOW PLUG CONTROL MODULE LOGIC MONITOR
O	C98-G3	GLOW PLUG CONTROL MODULE DRIVE: PWM, 100% = ON, 0% = OFF
O	C98-J4	FUEL PUMP, VOLUMETRIC CONTROL VALVE: PWM, 200 Hz
O	C98-K3	FUEL PUMP, PRESSURE CONTROL VALVE: PWM, 350 Hz
O	C98-L1	FUEL INJECTOR DRIVE - CYLINDER 4: TO ACTIVATE, PCM SWITCHES CIRCUIT TO GROUND
+	C98-L2	FUEL INJECTOR POWER SUPPLY - CYLINDER 4:
+	C98-L3	FUEL INJECTOR POWER SUPPLY - CYLINDER 5:
O	C98-M1	FUEL INJECTOR DRIVE - CYLINDER 5: TO ACTIVATE, PCM SWITCHES CIRCUIT TO GROUND
O	C98-M2	FUEL INJECTOR DRIVE - CYLINDER 6: TO ACTIVATE, PCM SWITCHES CIRCUIT TO GROUND
+	C98-M3	FUEL INJECTOR POWER SUPPLY - CYLINDER 6:
SS	C99-A4	CATALYTIC CONVERTER TEMPERATURE SENSOR - BANK 2 UPSTREAM SIGNAL:
SS	C99-D4	DPF TEMPERATURE SENSOR SIGNAL:
SS	C99-E3	CATALYTIC CONVERTER TEMPERATURE SENSOR - BANK 1 DOWNSTREAM SIGNAL:
SS	C99-E4	CATALYTIC CONVERTER TEMPERATURE SENSOR - BANK 2 DOWNSTREAM SIGNAL:
SG	C99-F3	SIGNAL GROUND FOR CATALYTIC CONVERTER TEMPERATURE SENSORS - BANK 2 AND DPF SENSOR: GROUND
SG	C99-F4	SIGNAL GROUND FOR CATALYTIC CONVERTER TEMPERATURE SENSORS - BANK 1: GROUND
+	C99-L2	FUEL INJECTOR POWER SUPPLY - CYLINDER 2:
+	C99-L3	FUEL INJECTOR POWER SUPPLY - CYLINDER 1:
+	C99-L4	FUEL INJECTOR POWER SUPPLY - CYLINDER 3:
O	C99-M2	FUEL INJECTOR DRIVE - CYLINDER 2: TO ACTIVATE, PCM SWITCHES CIRCUIT TO GROUND
O	C99-M3	FUEL INJECTOR DRIVE - CYLINDER 1: TO ACTIVATE, PCM SWITCHES CIRCUIT TO GROUND
O	C99-M4	FUEL INJECTOR DRIVE - CYLINDER 3: TO ACTIVATE, PCM SWITCHES CIRCUIT TO GROUND
SG	FH13-B3	AIR CONDITIONING PRESSURE SENSOR GROUND
SG	FH13-B4	SPEED CONTROL SWITCHES SIGNAL GROUND: GROUND
I	FH13-C4	SPEED CONTROL SWITCH REQUEST: STEPPED RESISTANCE
SS	FH13-D3	AIR CONDITIONING PRESSURE SENSOR POWER SUPPLY: NOMINAL 5 V
I	FH13-E3	BRAKE CANCEL SWITCH: NORMALLY CLOSED / GROUND WHEN ACTIVATED
I	FH13-F2	AIR CONDITIONING PRESSURE SENSOR SIGNAL, NOMINAL 0 - 5 V; TRANSDUCER - VOLTAGE INCREASES AS PRESSURE INCREASES
O	FH13-J2	AIR CONDITIONING COMPRESSOR CLUTCH RELAY DRIVE: TO ACTIVATE, PCM SWITCHES CIRCUIT TO GROUND
O	FH13-J4	FUEL LIFT PUMP DRIVE SIGNAL (TO FUEL LIFT PUMP RELAY): TO ACTIVATE, PCM SWITCHES CIRCUIT TO GROUND
O	FH13-K2	COOLING FAN MODULE CONTROL: PWM, 140 Hz, POSITIVE DUTY CYCLE RANGE 7% - 95%

The following abbreviations are used to represent values for Control Module Pin-Out data

I	Input	PG	Power Ground	C	CAN Network	D	Serial and Encoded Data
O	Output	SS	Sensor / Signal Supply V	S	SCP Network	V	Voltage (DC)
B+	Battery Voltage	SG	Sensor / Signal Ground	D2	D2B Network	PWM	Pulse Width Modulated

CAUTION: The information on this data page is furnished to aid the user in understanding circuit operation. THIS INFORMATION SHOULD BE USED FOR REFERENCE ONLY.

NOTE: The values listed are approximately those that can be expected at the control module connector pins with all circuit connections made and all components connected and fitted.

Fig. 03.8

COMPONENTS

Component	Connector(s)	Connector Description	Location
AIR CONDITIONING COMPRESSOR CLUTCH	PI49	2-WAY / BLACK	LOWER LH SIDE OF ENGINE
AIR CONDITIONING COMPRESSOR CLUTCH RELAY	—	—	FRONT POWER DISTRIBUTION FUSE-BOX-R8
AIR CONDITIONING PRESSURE SENSOR	FH110	3-WAY / BLACK	ENGINE COMPARTMENT, LH SIDE, HIGH PRESSURE REFRIGERANT LINE, BETWEEN COMPRESSOR AND CONDENSER
BRAKE CANCEL SWITCH	CA36	2-WAY / GREY	TOP OF BRAKE PEDAL
CATALYTIC CONVERTER TEMPERATURE SENSOR - BANK 1 DOWNSTREAM	GB7	—	RH CATALYTIC CONVERTER
CATALYTIC CONVERTER TEMPERATURE SENSOR - BANK 1 UPSTREAM	GB9	—	RH CATALYTIC CONVERTER
CATALYTIC CONVERTER TEMPERATURE SENSOR - BANK 2 DOWNSTREAM	GB6	—	LH CATALYTIC CONVERTER
CATALYTIC CONVERTER TEMPERATURE SENSOR - BANK 2 UPSTREAM	GB8	—	LH CATALYTIC CONVERTER
COOLING FAN MODULE	FH120	4-WAY / BLACK	ENGINE COMPARTMENT, RH FRONT, REARWARD OF RADIATOR
DOSING PUMP	CA307	2-WAY / BLACK	FUEL TANK, RH SIDE, ABOVE FUEL FILLER HOSE
DPF TEMPERATURE SENSOR	GB10	—	DPF INLET
FRONT POWER DISTRIBUTION FUSE BOX	—	—	ENGINE COMPARTMENT, RH SIDE
FUEL INJECTOR 1	C44	2-WAY / BLACK	REFER TO SENSORS AND ACTUATORS, PAGE 30 OR 31
FUEL INJECTOR 2	C46	2-WAY / BLACK	REFER TO SENSORS AND ACTUATORS, PAGE 30 OR 31
FUEL INJECTOR 3	C48	2-WAY / BLACK	REFER TO SENSORS AND ACTUATORS, PAGE 30 OR 31
FUEL INJECTOR 4	C45	2-WAY / BLACK	REFER TO SENSORS AND ACTUATORS, PAGE 30 OR 31
FUEL INJECTOR 5	C47	2-WAY / BLACK	REFER TO SENSORS AND ACTUATORS, PAGE 30 OR 31
FUEL INJECTOR 6	C49	2-WAY / BLACK	REFER TO SENSORS AND ACTUATORS, PAGE 30 OR 31
FUEL LIFT PUMP	—	—	FUEL TANK
FUEL LIFT PUMP RELAY	—	—	REAR POWER DISTRIBUTION FUSE BOX - R15
FUEL TANK CONNECTOR	FP13	6-WAY / BLACK	FUEL TANK, RH SIDE
FUEL-FIRED AUXILIARY HEATER MODULE	FH24	8-WAY / BLACK	BELOW LH HEADLAMP ASSEMBLY
	FH25	2-WAY / BLACK	
GLOW PLUG CONTROL MODULE	FH20	5-WAY / BLACK	ENGINE COMPARTMENT, RH FRONT, BRACKET, DSC MODULE
	FH23	EYELET	
	GP4	6-WAY	
GLOW PLUGS (BANK 1)	GP1	3-WAY / BLACK	REFER TO SENSORS AND ACTUATORS, PAGE 30 OR 31
GLOW PLUGS (BANK 2)	GP2	3-WAY / BLACK	REFER TO SENSORS AND ACTUATORS, PAGE 30 OR 31
POWERTRAIN CONTROL MODULE	C98	48-WAY / BROWN	FRONT BULKHEAD, PASSENGER SIDE
	C99	48-WAY / GREY	
	FH13	48-WAY / BLACK	
PRESSURE CONTROL VALVE (FUEL PUMP)	C43	2-WAY / BLACK	REFER TO SENSORS AND ACTUATORS, PAGE 30 OR 31
REAR ELECTRONIC MODULE	CA63	17-WAY / BLACK	LUGGAGE COMPARTMENT, RH REAR
	CA100	12-WAY / BLACK	
	CA101	20-WAY / BLACK	
	CA102	22-WAY / BLACK	
	CA103	26-WAY / NATURAL	
REAR POWER DISTRIBUTION FUSE BOX	—	—	LUGGAGE COMPARTMENT
STEERING WHEEL SPEED CONTROL SWITCHES	SQ2	6-WAY / BLACK	STEERING WHEEL
VOLUMETRIC CONTROL VALVE (FUEL PUMP)	C42	2-WAY / BLACK	REFER TO SENSORS AND ACTUATORS, PAGE 30 OR 31

HARNES IN-LINE CONNECTORS

Connector	Connector Description / Location	Location
FC10	14-WAY / GREEN / FASCIA HARNESS TO FRONT HARNESS	BEHIND INSTRUMENT PANEL, RH SIDE
FC117	10-WAY / BLACK / STEERING WHEEL CASSETTE	STEERING COLUMN
FH2	16-WAY / GREY / CABIN HARNESS TO FRONT HARNESS	RH 'A' POST, LOWER
FH3	16-WAY / BLUE / CABIN HARNESS TO FRONT HARNESS	LH 'A' POST
FH6	6-WAY / BLACK / ENGINE HARNESS TO FUEL INJECTOR LINK	ENGINE, LH REAR
FP2	8-WAY / BLACK / VEHICLE TO FUEL TANK HARNESS	BIW ABOVE FUEL TANK
GB11	12-WAY / GREY / ENGINE HARNESS TO GEARBOX HARNESSES	ENGINE, REAR
PI41	42-WAY / BLACK / ENGINE HARNESS TO VEHICLE HARNESSES	ENGINE COMPARTMENT, BULKHEAD, PASSENGER SIDE

GROUNDS

Ground	Location
CA30	LOWER 'A' POST, LH SIDE
CA50	LOWER 'A' POST, RH SIDE
CA116	RH 'C' POST, UPPER
CA156	LUGGAGE COMPARTMENT, RH SIDE
FH22	ENGINE COMPARTMENT, BEHIND LH HEADLAMP
FH42	ENGINE COMPARTMENT, BEHIND RH HEADLAMP
FH95	ENGINE COMPARTMENT, BEHIND LH HEADLAMP (RADIATOR FAN GROUND)

FOR CONTROL MODULE PIN-OUT INFORMATION, UNFOLD PAGE TO LEFT.

Refer to the front of this book for detailed information and illustrations regarding the location and identification of harnesses, relays, fuses, grounds, control modules and control module pins.

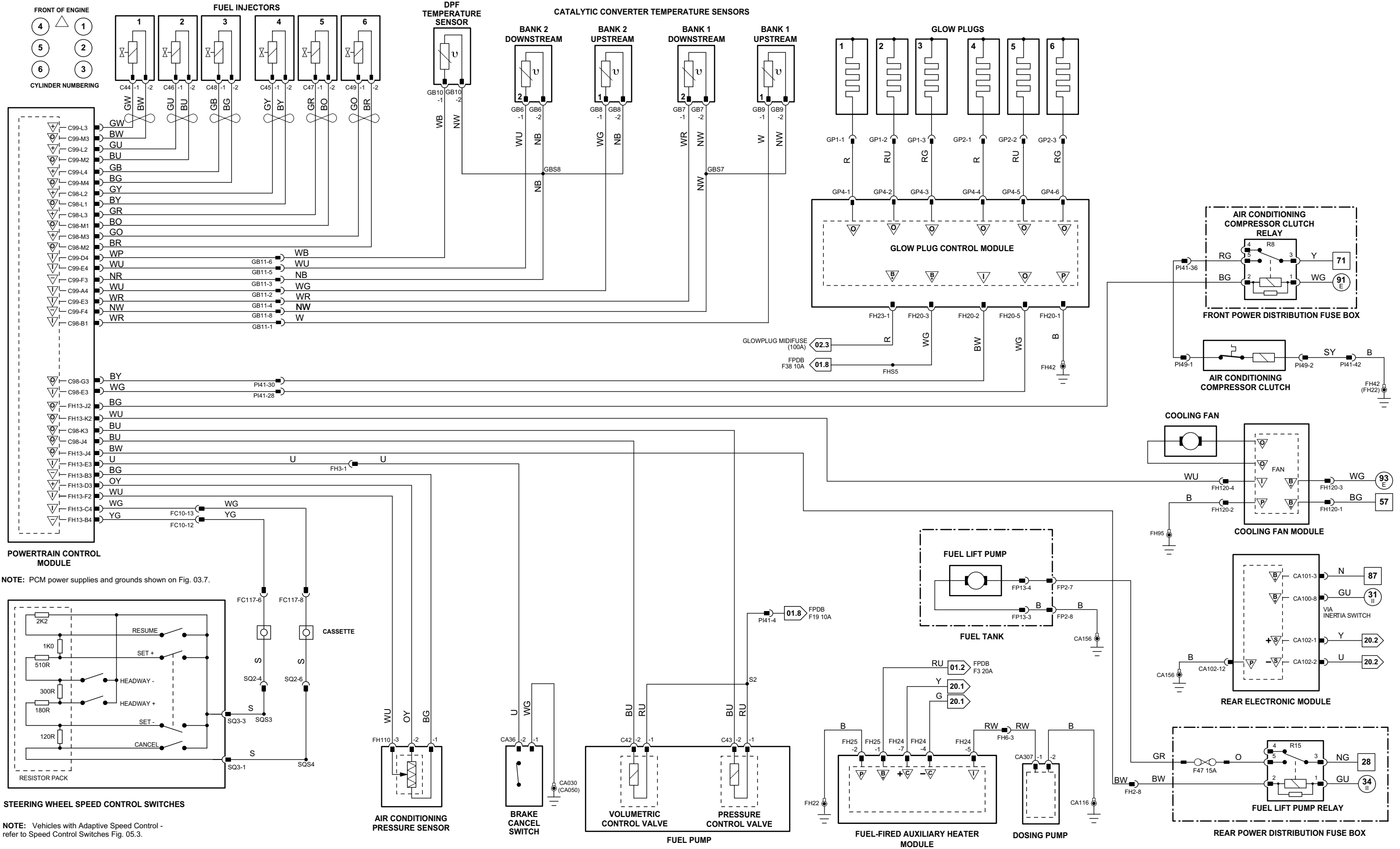

1 → 3 Fig. 01.1	4 → 76 Fig. 01.2	77 → 92 Fig. 01.3	1 → 14 Fig. 01.4	15 → 45 Fig. 01.5	46 → 80 Fig. 01.8	81 → 118 Fig. 01.7	Input	Battery Voltage	Sensor/Signal Supply V	CAN	D2B Network	VARIANT: Diesel 2.7V6
							Output	Power Ground	Sensor/Signal Ground	SCP	Serial and Encoded Data	VIN RANGE: All
												DATE OF ISSUE: April 2006

Powertrain Control Module

	Pin	Description and Characteristic
SG	FH300-07	SENSOR GROUND 1: GROUND
SG	FH300-08	SENSOR GROUND 2: GROUND
I	FH300-13	SAI MAP SENSOR SIGNAL:
SS	FH300-19	SENSOR POWER SUPPLY 2: NOMINAL 5 V
I	FH300-24	ACCELERATOR PEDAL POSITION SENSOR 1 SIGNAL: FOOT OFF = 0.75 V; FULLY DEPRESSED = 3.40 V (AUTO) 3.20 V (MAN)
SS	FH300-32	SENSOR POWER SUPPLY 1: NOMINAL 5 V
I	FH300-38	ACCELERATOR PEDAL POSITION SENSOR 2 SIGNAL: FOOT OFF = 3.38 V; FULLY DEPRESSED = 2.05 V (AUTO) 2.14 V (MAN)
O	FH300-50	SAI RELAY DRIVE:
O	FH300-55	SAI VACUUM SOLENOID DRIVE:

Fig. 03.9

COMPONENTS

Component	Connector(s)	Connector Description	Location
APP SENSOR	CA88	6-WAY / BLACK	TOP OF ACCELERATOR PEDAL
ENGINE CONTROL MODULE	FH300	58-WAY / BLACK	FRONT BULKHEAD, PASSENGER SIDE
	PI300	96-WAY / BLACK	
FRONT POWER DISTRIBUTION FUSE BOX	—	—	ENGINE COMPARTMENT, RH SIDE
SECONDARY AIR INJECTION MAP SENSOR	FH312	3-WAY / BLACK	TO BE CONFIRMED
SECONDARY AIR INJECTION PUMP	FH310	2-WAY / GREY	BEHIND RH SIDE OF FRONT BUMPER COVER
SECONDARY AIR INJECTION RELAY			FRONT POWER DISTRIBUTION FUSE BOX - R19
VACUUM SOLENOID	PI302	2-WAY / BLACK	ENGINE REAR

HARNESS IN-LINE CONNECTORS

Connector	Connector Description / Location	Location
FC12	14-WAY / GREY / FASCIA HARNESS TO FRONT HARNESS	BEHIND INSTRUMENT PANEL, PASSENGER SIDE
FC26	16-WAY / BLUE / CABIN HARNESS TO FASCIA HARNESS	BEHIND INSTRUMENT PANEL, DRIVER SIDE

GROUND

Ground	Location
FH22	ENGINE COMPARTMENT, BEHIND LH HEADLAMP

The following abbreviations are used to represent values for Control Module Pin-Out data

I	Input	PG	Power Ground	C	CAN Network	D	Serial and Encoded Data
O	Output	SS	Sensor / Signal Supply V	S	SCP Network	V	Voltage (DC)
B+	Battery Voltage	SG	Sensor / Signal Ground	D2	D2B Network	PWM	Pulse Width Modulated

CAUTION: The information on this data page is furnished to aid the user in understanding circuit operation. THIS INFORMATION SHOULD BE USED FOR REFERENCE ONLY.

NOTE: The values listed are approximately those that can be expected at the control module connector pins with all circuit connections made and all components connected and fitted.

Refer to the front of this book for detailed information and illustrations regarding the location and identification of harnesses, relays, fuses, grounds, control modules and control module pins.

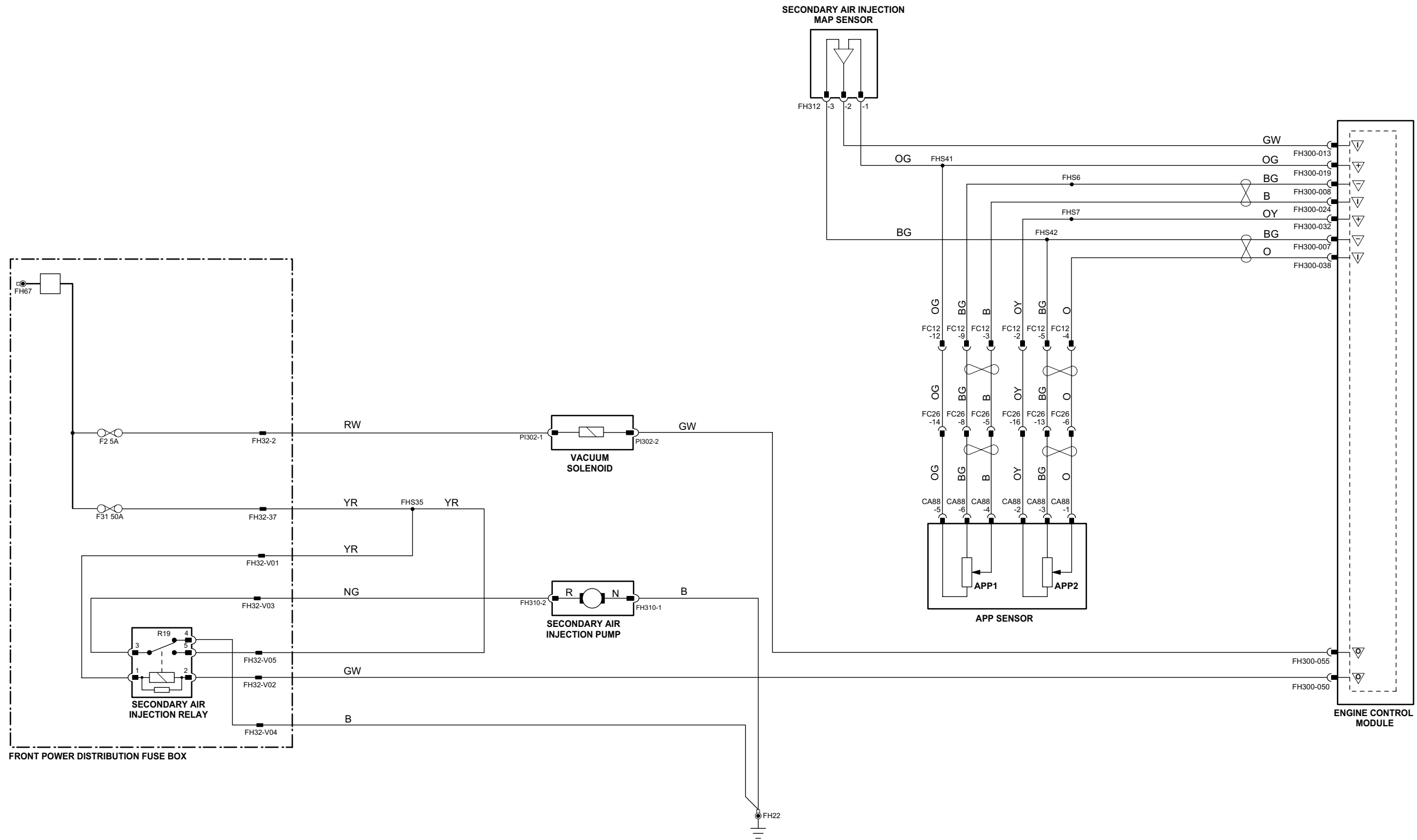

Transmission Control Module

	Pin	Description and Characteristic
C	GB2-2	CAN -
D	GB2-3	SERIAL COMMUNICATION
C	GB2-6	CAN +
B+	GB2-9	IGNITION SWITCHED POWER SUPPLY: B+
O	GB2-10	PARK / NEUTRAL SIGNAL: GROUND WHEN ACTIVATED
PG	GB2-13	POWER GROUND: GROUND
B+	GB2-14	BATTERY POWER SUPPLY: B+
PG	GB2-16	POWER GROUND: GROUND

Fig. 04.1

COMPONENTS

Component	Connector(s)	Connector Description	Location
IGNITION SWITCH	FC18	7-WAY / BLACK	STEERING COLUMN COWLING
J-GATE MODULE	CA245	16-WAY / BLACK	J-GATE ASSEMBLY
TRANSMISSION CAPACITOR (DIESEL)	GB17	2-WAY / BLACK	ENGINE COMPARTMENT, BULKHEAD
TRANSMISSION CAPACITOR (GASOLINE)	PI59	2-WAY / BLACK	ENGINE COMPARTMENT, BULKHEAD
TRANSMISSION CONTROL MODULE	GB2	16-WAY / BLACK	TRANSMISSION CONTROL VALVE ASSEMBLY

HARNESS IN-LINE CONNECTORS

Connector	Connector Description / Location	Location
FC26	16-WAY / BLUE / CABIN HARNESS TO FASCIA HARNESS	BEHIND INSTRUMENT PANEL, DRIVER SIDE
GB1	16-WAY / GREY / ENGINE HARNESS TO TRANSMISSION HARNESS	ADJACENT TO TRANSMISSION BELL HOUSING
PI41	42-WAY / BLACK / ENGINE HARNESS TO VEHICLE HARNESSES	ENGINE COMPARTMENT, BULKHEAD, PASSENGER SIDE

GROUNDS

Ground	Location
CA154	UNDER LH FRONT SEAT
FH4 (LHD)	ENGINE COMPARTMENT, REARWARD OF RH WHEEL ARCH
FH4 (RHD)	ENGINE COMPARTMENT, REARWARD OF LH WHEEL ARCH
PI40 (LHD)	ENGINE COMPARTMENT, BEHIND RH WHEEL ARCH LINER
PI40 (RHD)	ENGINE COMPARTMENT, BEHIND LH WHEEL ARCH LINER

FOR CONTROL MODULE PIN-OUT INFORMATION, UNFOLD PAGE TO LEFT.

The following abbreviations are used to represent values for Control Module Pin-Out data

I	Input	PG	Power Ground	C	CAN Network	D	Serial and Encoded Data
O	Output	SS	Sensor / Signal Supply V	S	SCP Network	V	Voltage (DC)
B+	Battery Voltage	SG	Sensor / Signal Ground	D2	D2B Network	PWM	Pulse Width Modulated

CAUTION: The information on this data page is furnished to aid the user in understanding circuit operation. THIS INFORMATION SHOULD BE USED FOR REFERENCE ONLY.

NOTE: The values listed are approximately those that can be expected at the control module connector pins with all circuit connections made and all components connected and fitted.

Refer to the front of this book for detailed information and illustrations regarding the location and identification of harnesses, relays, fuses, grounds, control modules and control module pins.

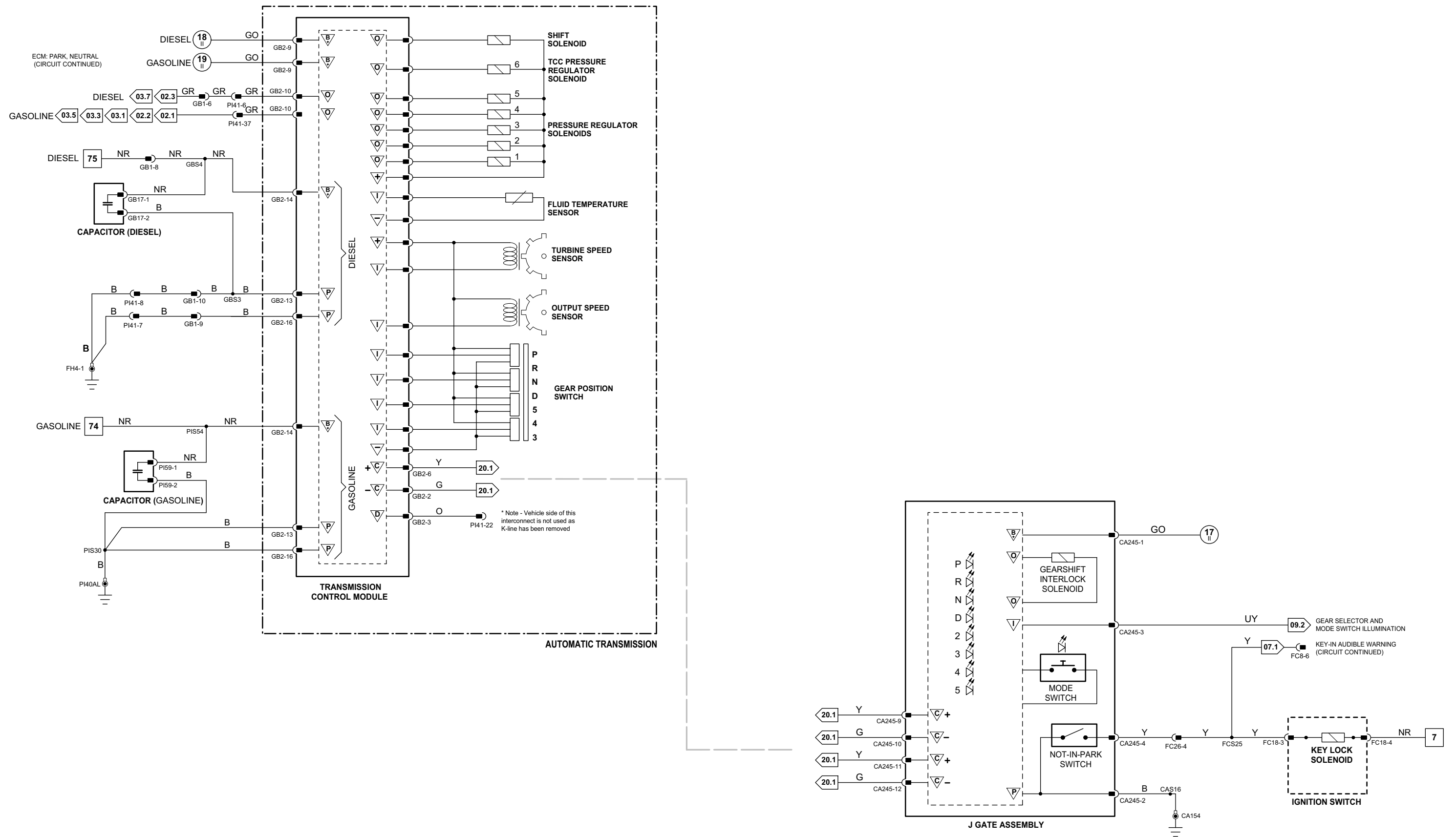

1 → 3 Fig. 01.1	4 → 76 Fig. 01.2	77 → 92 Fig. 01.3	1 → 14 Fig. 01.4	15 → 45 Fig. 01.5	46 → 80 Fig. 01.8	81 → 118 Fig. 01.7	Input Output	Battery Voltage Power Ground	Sensor/Signal Supply V Sensor/Signal Ground	CAN SCP	D2B Network Serial and Encoded Data
--------------------	---------------------	----------------------	---------------------	----------------------	----------------------	-----------------------	-----------------	---------------------------------	--	------------	--

VARIANT: Automatic Vehicles
 VIN RANGE: All
 DATE OF ISSUE: April 2006

Fig. 04.2

Parking Brake Module

	Pin	Description and Characteristic
I	CA265-6	CLUTCH PEDAL POSITION SENSOR FEEDBACK SIGNAL: VARIABLE VOLTAGE
SG	CA266-3	CLUTCH PEDAL POSITION SENSOR GROUND: GROUND
SS	CA265-5	CLUTCH PEDAL POSITION SENSOR SUPPLY VOLTAGE: NOMINAL 5 V
I	CA265-3	IN-GEAR SWITCH (NORMALLY OPEN): OPEN CIRCUIT / GROUND
I	CA266-15	IN-GEAR SWITCH (NORMALLY OPEN): OPEN CIRCUIT / GROUND

Engine Control Module (Gasoline)

	Pin	Description and Characteristic
I	FH300-43	CLUTCH CANCEL SWITCH: NORMALLY CLOSED / GROUND WHEN ACTIVATED

Powertrain Control Module (Diesel)

	Pin	Description and Characteristic
I	FH13-G3	CLUTCH CANCEL SWITCH: NORMALLY CLOSED / GROUND WHEN ACTIVATED

COMPONENTS

Component	Connector(s)	Connector Description	Location
CLUTCH CANCEL SWITCH	CA285 (RHD) CA291 (LHD)	2-WAY / BLACK 5-WAY / BLACK	TOP OF CLUTCH PEDAL (TOP SWITCH)
CLUTCH PEDAL POSITION SENSOR	CA287	6-WAY / BLACK	TOP OF CLUTCH PEDAL
ENGINE CONTROL MODULE	FH300 PI300	58-WAY / BLACK 96-WAY / BLACK	FRONT BULKHEAD, PASSENGER SIDE FRONT BULKHEAD, PASSENGER SIDE
NEUTRAL SWITCH (DIESEL)	GB4	4-WAY / GREY	TRANSMISSION, LH REAR
NEUTRAL SWITCH (GASOLINE)	GB3	2-WAY / BLACK	TRANSMISSION, LH REAR
PARKING BRAKE MODULE	CA265 CA266	14-WAY / GREY 24-WAY / BLACK	LUGGAGE COMPARTMENT, RH REAR
POWERTRAIN CONTROL MODULE	C98 C99	48-WAY / BROWN 48-WAY / GREY	FRONT BULKHEAD, PASSENGER SIDE
REVERSE SWITCH	FH13 GB5	48-WAY / BLACK 2-WAY / BLACK	TRANSMISSION, LH REAR

HARNESS IN-LINE CONNECTORS

Connector	Connector Description / Location	Location
FH1	22-WAY / DARK GREY / CABIN HARNESS TO FRONT HARNESS	RH 'A' POST, LOWER
FH2	16-WAY / GREY / CABIN HARNESS TO FRONT HARNESS	RH 'A' POST, LOWER
FH3	16-WAY / BLUE / CABIN HARNESS TO FRONT HARNESS	LH 'A' POST
GB1	16-WAY / GREY / ENGINE HARNESS TO TRANSMISSION HARNESS	ADJACENT TO TRANSMISSION BELL HOUSING
PI41	42-WAY / BLACK / ENGINE HARNESS TO VEHICLE HARNESSES	ENGINE COMPARTMENT, BULKHEAD, PASSENGER SIDE
PI42	8-WAY / BLACK / ENGINE HARNESS TO FRONT HARNESS	ENGINE COMPARTMENT, BULKHEAD, PASSENGER SIDE

GROUNDS

Ground	Location
CA30	LOWER 'A' POST, LH SIDE
CA50	LOWER 'A' POST, RH SIDE
FH4 (LHD)	ENGINE COMPARTMENT, REARWARD OF RH WHEEL ARCH
FH4 (RHD)	ENGINE COMPARTMENT, REARWARD OF LH WHEEL ARCH
PI40 (LHD)	ENGINE COMPARTMENT, BEHIND RH WHEEL ARCH LINER
PI40 (RHD)	ENGINE COMPARTMENT, BEHIND LH WHEEL ARCH LINER

FOR CONTROL MODULE PIN-OUT INFORMATION, UNFOLD PAGE TO LEFT.

The following abbreviations are used to represent values for Control Module Pin-Out data

I	Input	PG	Power Ground	C	CAN Network	D	Serial and Encoded Data
O	Output	SS	Sensor / Signal Supply V	S	SCP Network	V	Voltage (DC)
B+	Battery Voltage	SG	Sensor / Signal Ground	D2	D2B Network	PWM	Pulse Width Modulated

CAUTION: The information on this data page is furnished to aid the user in understanding circuit operation. THIS INFORMATION SHOULD BE USED FOR REFERENCE ONLY.

NOTE: The values listed are approximately those that can be expected at the control module connector pins with all circuit connections made and all components connected and fitted.

Refer to the front of this book for detailed information and illustrations regarding the location and identification of harnesses, relays, fuses, grounds, control modules and control module pins.

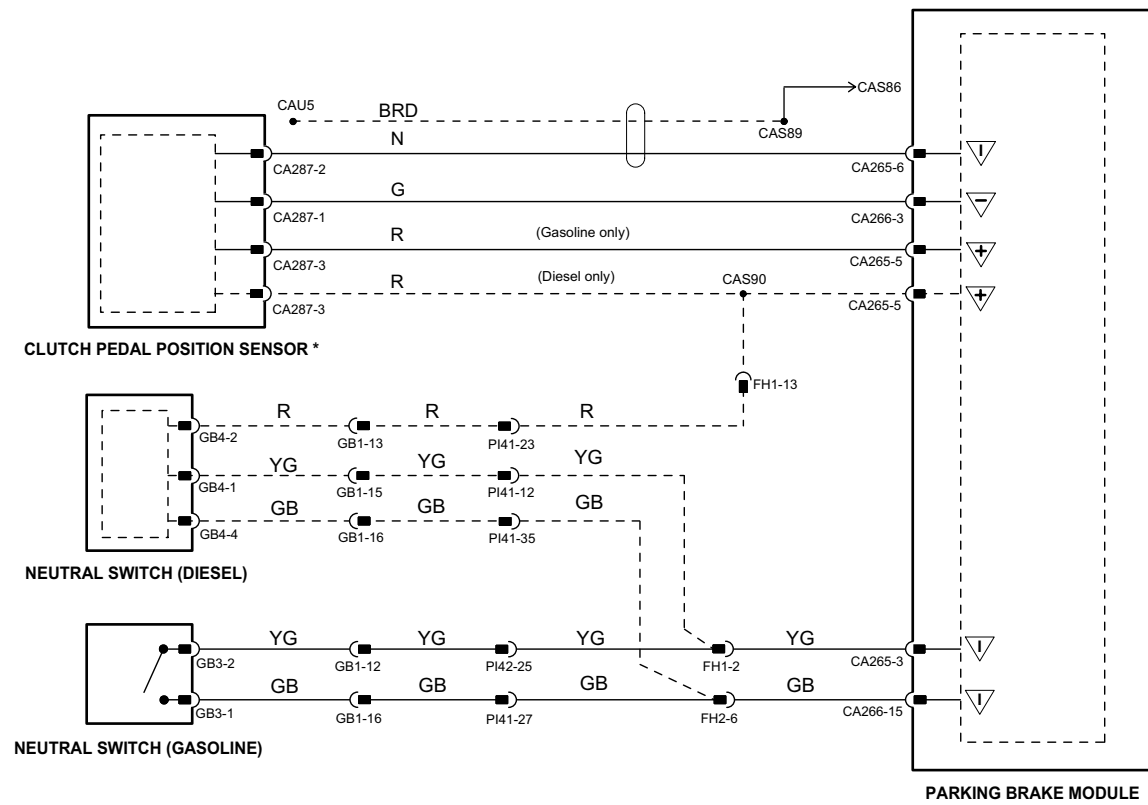
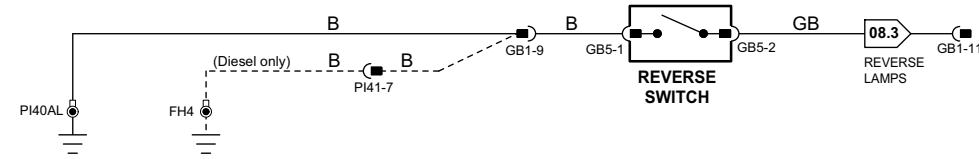
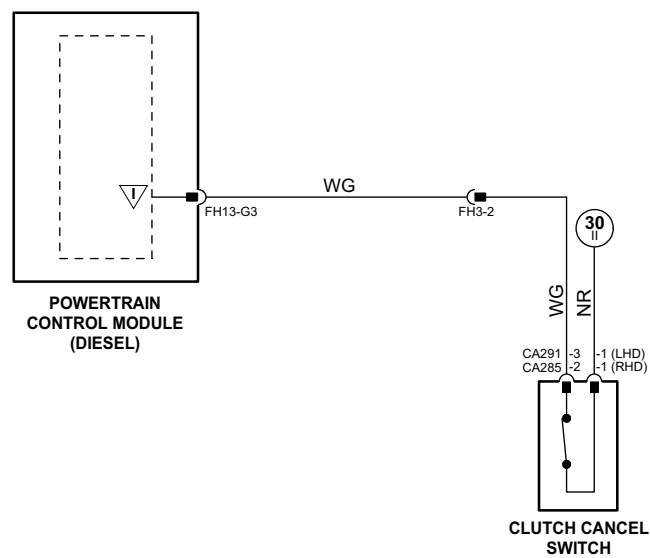
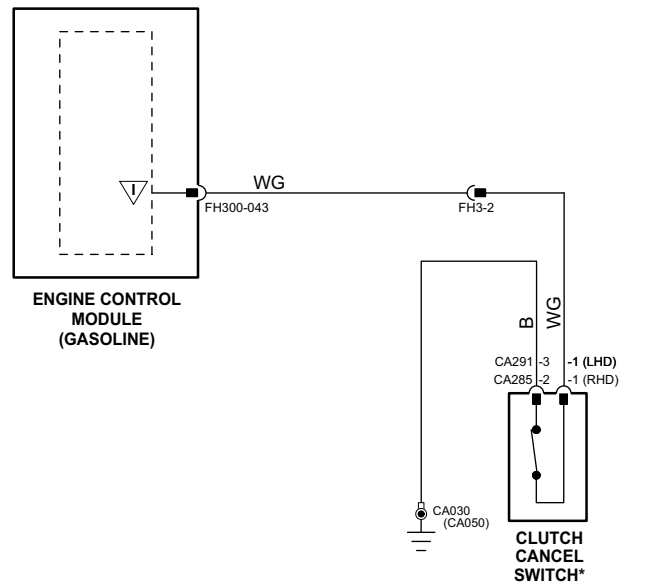

* NOTE: Early production vehicles - feature not enabled.

Dynamic Stability Control Module

Pin	Description and Characteristic
B+	FH103-1 BATTERY POWER SUPPLY – PUMP: B+
B+	FH103-2 BATTERY POWER SUPPLY – ECU: B+
I	FH103-4 DYNAMIC STABILITY CONTROL SWITCH: NORMALLY OPEN / GROUND WHEN ACTIVATED
SS	FH103-5 STEERING ANGLE SENSORS SUPPLY VOLTAGE: B+
I	FH103-6 BRAKE FLUID LEVEL SENSOR SIGNAL: BRAKE FLUID LEVEL LOW = GROUND
SG	FH103-7 BRAKE FLUID LEVEL SENSOR SIGNAL GROUND: GROUND
B+	FH103-8 IGNITION SWITCHED POWER SUPPLY (II): B+
I	FH103-9 STEERING ANGLE SENSOR SIGNAL (B): PULSED SIGNAL
C	FH103-11 CAN +
C	FH103-12 CAN +
C	FH103-13 CAN –
C	FH103-14 CAN –
PG	FH103-16 POWER GROUND – VALVES: GROUND
C	FH103-18 CAN + (LOCAL)
C	FH103-19 CAN – (LOCAL)
SS	FH103-22 YAW RATE SENSOR CLUSTER SUPPLY VOLTAGE: B+
SS	FH103-26 VACUUM SENSORS SUPPLY VOLTAGE: B+
SG	FH103-27 VACUUM SENSOR GROUND: GROUND
SG	FH103-29 YAW RATE SENSOR CLUSTER GROUND: GROUND
I	FH103-30 VACUUM SENSOR SIGNAL 2:
B+	FH103-32 BATTERY POWER SUPPLY – VALVES: B+
I	FH103-33 RH FRONT WHEEL SPEED SENSOR SIGNAL: 46 PULSES PER WHEEL REVOLUTION
SG	FH103-34 RH FRONT WHEEL SPEED SENSOR SIGNAL GROUND: GROUND
O	FH103-35 VEHICLE SPEED SIGNAL (SLIDING ROOF THRESHOLD): < 62 KM/H (38.5 MPH) = GROUND; > 62 KM/H (38.5 MPH) = B+
I	FH103-36 LH REAR WHEEL SPEED SENSOR SIGNAL: 46 PULSES PER WHEEL REVOLUTION
SG	FH103-37 LH REAR WHEEL SPEED SENSOR SIGNAL GROUND: GROUND
I	FH103-38 VACUUM SENSOR SIGNAL 1:
SG	FH103-40 SENSOR GROUND – STEERING ANGLE SENSORS: GROUND
—	FH103-41 STEERING ANGLE SENSOR SIGNAL (A): PULSED SIGNAL
SG	FH103-42 RH REAR WHEEL SPEED SENSOR SIGNAL GROUND: GROUND
I	FH103-43 RH REAR WHEEL SPEED SENSOR SIGNAL: 46 PULSES PER WHEEL REVOLUTION
SG	FH103-45 LH FRONT WHEEL SPEED SENSOR SIGNAL GROUND: GROUND
I	FH103-46 LH FRONT WHEEL SPEED SENSOR SIGNAL: 46 PULSES PER WHEEL REVOLUTION
PG	FH103-47 POWER GROUND – PUMP: GROUND

The following abbreviations are used to represent values for Control Module Pin-Out data

I	Input	PG	Power Ground	C	CAN Network	D	Serial and Encoded Data
O	Output	SS	Sensor / Signal Supply V	S	SCP Network	V	Voltage (DC)
B+	Battery Voltage	SG	Sensor / Signal Ground	D2	D2B Network	PWM	Pulse Width Modulated

CAUTION: The information on this data page is furnished to aid the user in understanding circuit operation. THIS INFORMATION SHOULD BE USED FOR REFERENCE ONLY.

NOTE: The values listed are approximately those that can be expected at the control module connector pins with all circuit connections made and all components connected and fitted.

Fig. 05.1

COMPONENTS

Component	Connector(s)	Connector Description	Location
BRAKE FLUID RESERVOIR	FH104	2-WAY / BLACK	BRAKE BOOSTER
CENTER CONSOLE SWITCH PACK	FC113	8-WAY / BLACK	CENTER CONSOLE
	FC119	8-WAY / BLACK	
DSC VACUUM SENSOR	FH130	4-WAY / BLACK	ENGINE COMPARTMENT, VACUUM BRAKE BOOSTER
DYNAMIC STABILITY CONTROL MODULE	FH103	47-WAY / BLACK	ENGINE COMPARTMENT, RH FRONT
STEERING ANGLE SENSOR	FC110	4-WAY / GREY	STEERING COLUMN
WHEEL SPEED SENSOR – LH FRONT	FH115	2-WAY / BLACK	LH FRONT WHEEL HUB
WHEEL SPEED SENSOR – LH REAR	RL1	2-WAY / BLACK	LH REAR WHEEL HUB
WHEEL SPEED SENSOR – RH FRONT	FH116	2-WAY / BLACK	RH FRONT WHEEL HUB
WHEEL SPEED SENSOR – RH REAR	RR1	2-WAY / BLACK	RH REAR WHEEL HUB
YAW RATE AND LATERAL ACCELERATION SENSORS CLUSTER	CA236	6-WAY / BLACK	UNDER CENTER CONSOLE

HARNESS IN-LINE CONNECTORS

Connector	Connector Description / Location	Location
FC10	14-WAY / GREEN / FASCIA HARNESS TO FRONT HARNESS	BEHIND INSTRUMENT PANEL, RH SIDE
FH1	22-WAY / DARK GREY / CABIN HARNESS TO FRONT HARNESS	RH 'A' POST, LOWER
FH2	16-WAY / GREY / CABIN HARNESS TO FRONT HARNESS	RH 'A' POST, LOWER
FH6	16-WAY GREEN / CABIN HARNESS TO FRONT HARNESS	LH 'A' POST, ADJACENT TO FEM
RL2	2-WAY / BLACK / LH REAR LINK	REAR SUSPENSION SUBFRAME RH SIDE
RR2	2-WAY / BLACK / RH REAR LINK	REAR SUSPENSION SUBFRAME RH SIDE

GROUNDS

Ground	Location
FC38	UNDER CENTER OF INSTRUMENT PANEL, ON TRANSMISSION TUNNEL
FH50	ENGINE COMPARTMENT, RH SIDE

FOR CONTROL MODULE PIN-OUT INFORMATION, UNFOLD PAGE TO LEFT.

Refer to the front of this book for detailed information and illustrations regarding the location and identification of harnesses, relays, fuses, grounds, control modules and control module pins.

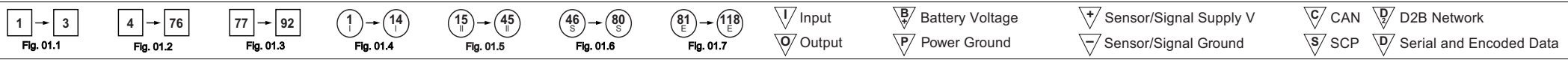
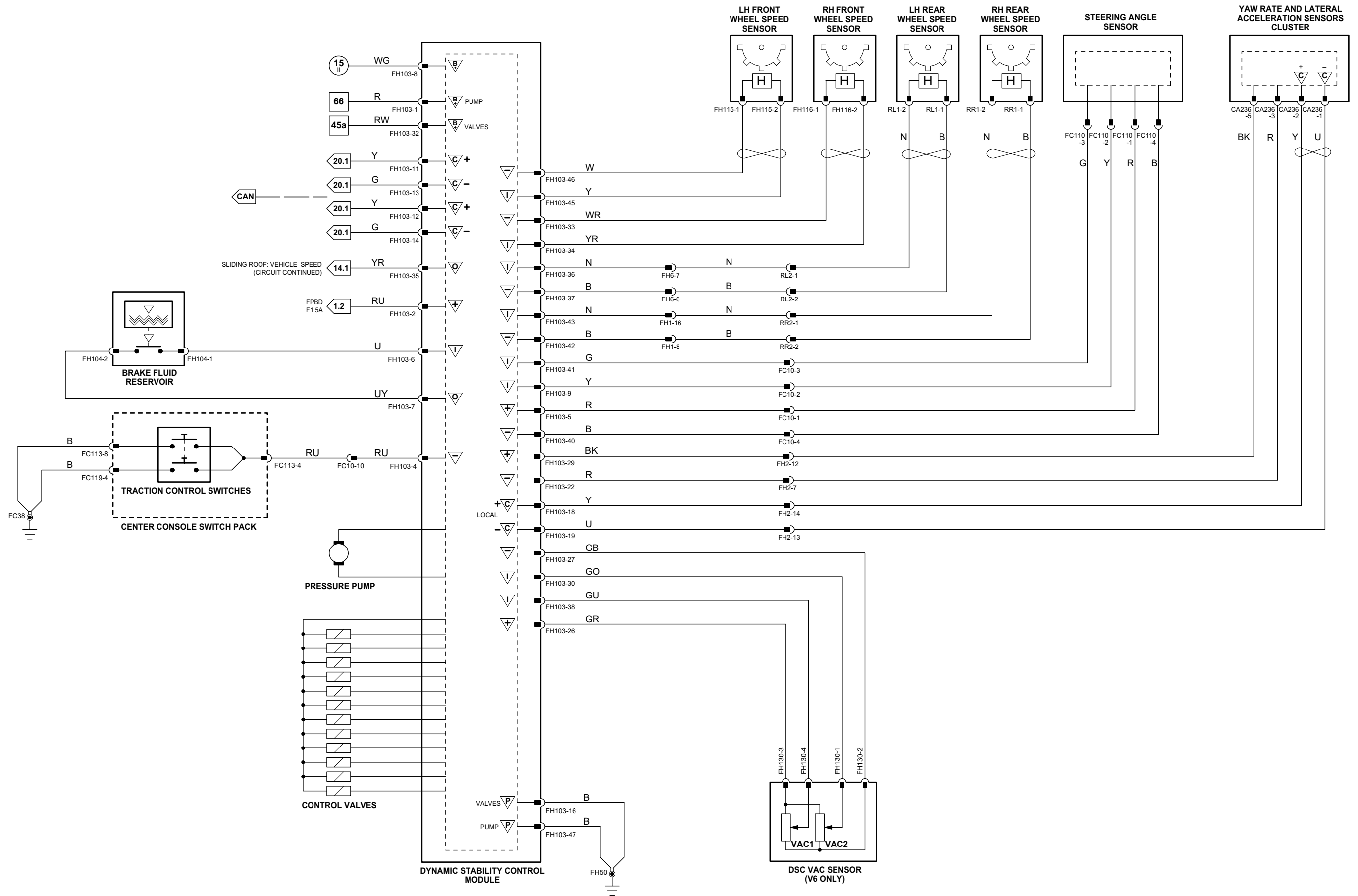

VARIANT: All Vehicles
 VIN RANGE: All
 DATE OF ISSUE: April 2006

Fig. 05.2

Parking Brake Module

	Pin	Description and Characteristic
I	CA265-3	IN-GEAR SWITCH (NORMALLY OPEN): OPEN CIRCUIT / GROUND
SS	CA265-5	SIGNAL SUPPLY VOLTAGE: NOMINAL 5 V
I	CA265-6	CLUTCH PEDAL POSITION SENSOR FEEDBACK SIGNAL: VARIABLE VOLTAGE
O	CA265-7	PARKING BRAKE MOTOR ENGAGE: ACTIVATE = B+
I	CA265-10	PARKING BRAKE SWITCH – APPLY: CHANGE IN RESISTANCE
I	CA265-11	PARKING BRAKE SWITCH – RELEASE: CHANGE IN RESISTANCE
SS	CA265-12	SIGNAL SUPPLY VOLTAGE: NOMINAL 5 V
SG	CA265-13	SIGNAL GROUND: GROUND
O	CA265-14	PARKING BRAKE MOTOR DISENGAGE: ACTIVATE = B+
B+	CA266-1	BATTERY POWER SUPPLY: B+
I	CA266-2	EPB SECONDARY APPLY SWITCH
SG	CA266-3	SIGNAL GROUND: GROUND
S	CA266-4	SCP –
S	CA266-5	SCP +
SG	CA266-6	EPB SWITCH GROUND
I	CA266-7	BRAKE SWITCH INPUT
B+	CA266-9	IGNITION SUPPLY
SS	CA266-10	PARKING BRAKE MOTOR POSITION SENSOR FEEDBACK SIGNAL: VARIABLE VOLTAGE
SS	CA266-11	LOGIC BATTERY POSITIVE INPUT
PG	CA266-13	POWER GROUND: GROUND
I	CA266-14	EPB SECONDARY RELEASE SWITCH
SG	CA266-15	NEUTRAL SWITCH GROUND
I	CA266-20	PRIMARY KEY SWITCH

Front Electronic Module

	Pin	Description and Characteristic
S	FH59-1	SCP –
S	FH59-7	SCP +
PG	FH59-12	POWER GROUND: GROUND
B+	FH60-1	SWITCHED SYSTEM POWER SUPPLY: B+
I	FH60-2	VARIABLE ASSIST STEERING ACTUATOR RETURN: VARIABLE VOLTAGE
O	FH60-9	VARIABLE ASSIST STEERING ACTUATOR DRIVE: B+ (PWM)
PG	FH60-11	POWER GROUND: GROUND
PG	FH60-13	POWER GROUND: GROUND
PG	FH60-14	POWER GROUND: GROUND
PG	FH60-15	POWER GROUND: GROUND

The following abbreviations are used to represent values for Control Module Pin-Out data

I	Input	PG	Power Ground	C	CAN Network	D	Serial and Encoded Data
O	Output	SS	Sensor / Signal Supply V	S	SCP Network	V	Voltage (DC)
B+	Battery Voltage	SG	Sensor / Signal Ground	D2	D2B Network	PWM	Pulse Width Modulated

CAUTION: The information on this data page is furnished to aid the user in understanding circuit operation. THIS INFORMATION SHOULD BE USED FOR REFERENCE ONLY.

NOTE: The values listed are approximately those that can be expected at the control module connector pins with all circuit connections made and all components connected and fitted.

COMPONENTS

Component	Connector(s)	Connector Description	Location
CLUTCH PEDAL POSITION SENSOR	CA287	6-WAY / BLACK	TOP OF CLUTCH PEDAL
ELECTRONIC PARKING BRAKE SWITCH	CA243	8-WAY / BLACK	CENTER CONSOLE
FRONT ELECTRONIC MODULE	CA24	26-WAY / NATURAL	LH 'A' POST
	CA31	20-WAY / BLACK	
	FH9	22-WAY / BLACK	
	FH59	12-WAY / BLACK	
	FH60	17-WAY / BLACK	
IGNITION SWITCH	FC18	7-WAY / BLACK	STEERING COLUMN COWLING
NEUTRAL SWITCH (DIESEL)	GB4	4-WAY / GREY	TRANSMISSION, LH REAR
NEUTRAL SWITCH (GASOLINE)	GB3	2-WAY / BLACK	TRANSMISSION, LH REAR
PARKING BRAKE MODULE	CA265	14-WAY / GREY	LUGGAGE COMPARTMENT, RH REAR
	CA266	24-WAY / BLACK	
PARKING BRAKE MOTOR	CA269	6-WAY / GREY	REAR SUSPENSION SUBFRAME
REAR POWER DISTRIBUTION FUSE BOX			LUGGAGE COMPARTMENT
VARIABLE ASSIST STEERING ACTUATOR	FH16	2-WAY / BLACK	STEERING RACK PINION HOUSING

HARNESS IN-LINE CONNECTORS

Connector	Connector Description / Location	Location
FC39	10-WAY / GREY / CABIN HARNESS TO FASCIA HARNESS	BEHIND INSTRUMENT PANEL, RH SIDE
FH1	22-WAY / DARK GREY / CABIN HARNESS TO FRONT HARNESS	RH 'A' POST, LOWER
FH2	16-WAY / GREY / CABIN HARNESS TO FRONT HARNESS	RH 'A' POST, LOWER
FH16	2-WAY / BLACK / STEERING ACTUATOR TO FRONT ELECTRONIC MODULE	STEERING COLUMN
GB1	16-WAY / GREY / ENGINE HARNESS TO TRANSMISSION HARNESS	ADJACENT TO TRANSMISSION BELL HOUSING
PI41	42-WAY / BLACK / ENGINE HARNESS TO VEHICLE HARNESS	ENGINE COMPARTMENT, BULKHEAD, PASSENGER SIDE
PI42	8-WAY / BLACK / ENGINE HARNESS TO FRONT HARNESS	ENGINE COMPARTMENT, BULKHEAD, PASSENGER SIDE

GROUNDS

Ground	Location
CA141	UNDER LH FRONT SEAT
CA156	LUGGAGE COMPARTMENT, RH SIDE
FH77	LH LOWER 'A' POST, ADJACENT TO THE FRONT ELECTRONIC MODULE (FORWARD OF CA30)

FOR CONTROL MODULE PIN-OUT INFORMATION, UNFOLD PAGE TO LEFT.

Refer to the front of this book for detailed information and illustrations regarding the location and identification of harnesses, relays, fuses, grounds, control modules and control module pins.

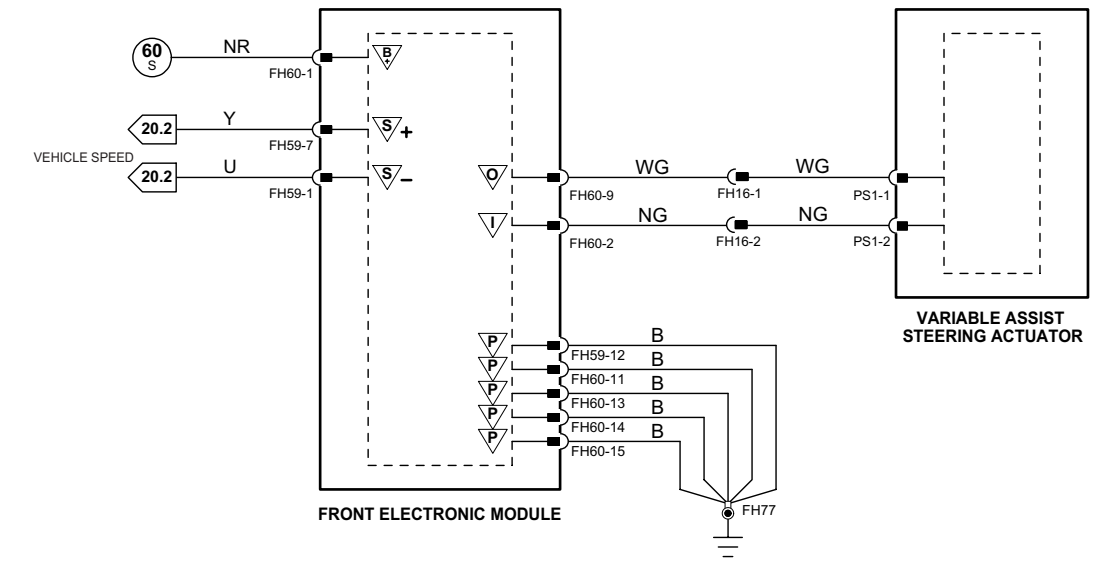
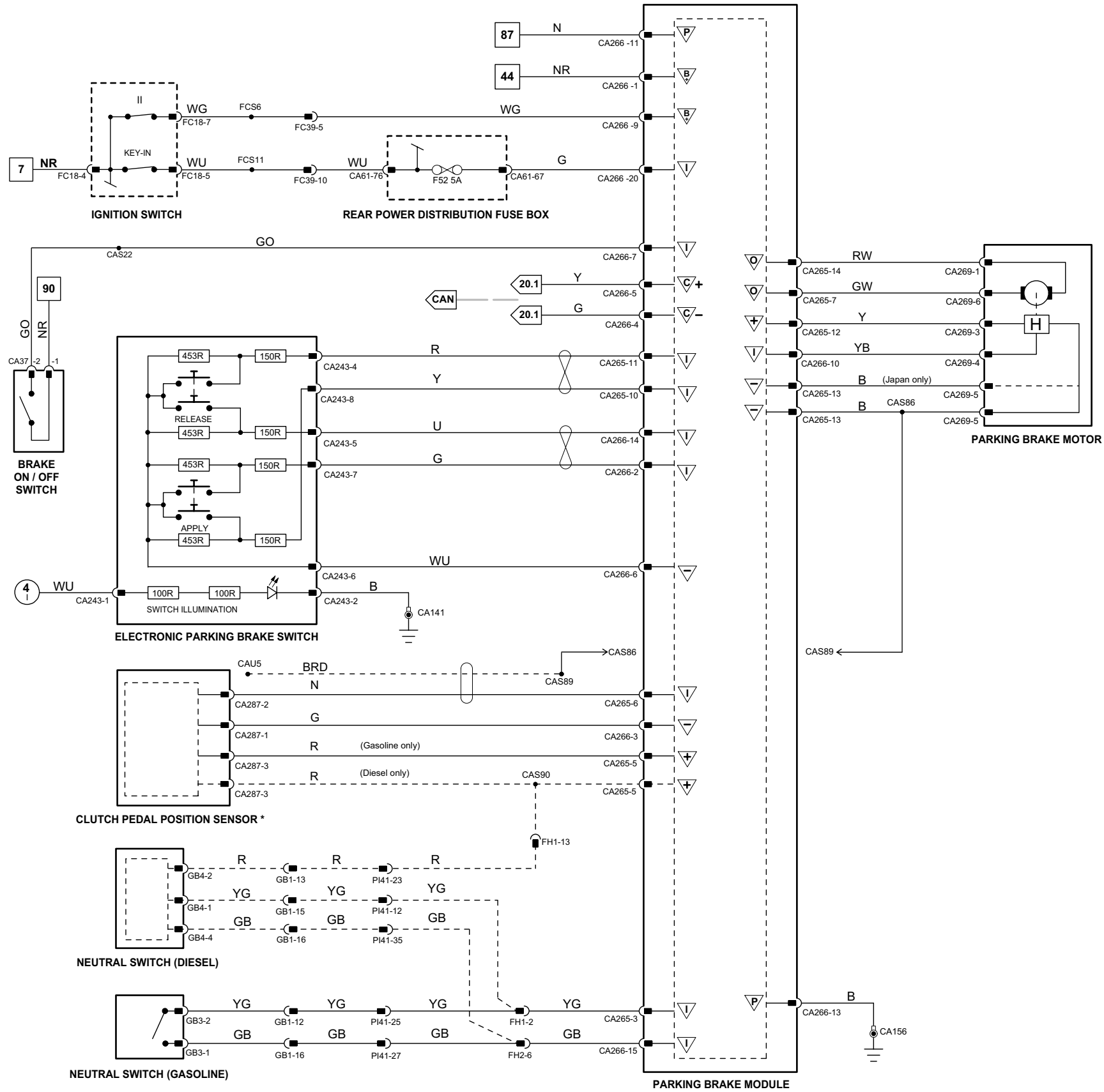

ELECTRONIC PARKING BRAKE

VARIABLE ASSIST POWER STEERING

NOTE: Neutral Switch and Clutch Pedal Position Sensor – manual transmission vehicles only.
 * Early production vehicles – feature not enabled.

1 → 3 Fig. 01.1	4 → 76 Fig. 01.2	77 → 92 Fig. 01.3	1 → 14 Fig. 01.4	15 → 45 Fig. 01.5	46 → 80 Fig. 01.8	81 → 118 Fig. 01.7	Input	Battery Voltage	Sensor/Signal Supply V	CAN	D2B Network
							Output	Power Ground	Sensor/Signal Ground	SCP	Serial and Encoded Data

VARIANT: All Vehicles
 VIN RANGE: All
 DATE OF ISSUE: April 2006

Fig. 05.3

Speed Control Module

	Pin	Description and Characteristic
C	FC6-2	CAN - LOCAL TO SPEED CONTROL SENSOR
C	FC6-3	CAN + LOCAL TO SPEED CONTROL SENSOR
O	FC6-5	FORWARD ALERT SWITCH / INDICATOR DRIVE: FORWARD ALERT INDICATOR DRIVE
C	FC6-8	CAN -
C	FC6-9	CAN +
PG	FC6-12	POWER GROUND: GROUND
B+	FC6-14	IGNITION SWITCHED POWER SUPPLY: B+
B+	FC6-15	SWITCHED SYSTEM POWER SUPPLY: B+
I	FC6-20	FORWARD ALERT SWITCH / INDICATOR DRIVE: MONITOR FORWARD ALERT SWITCH
C	FC6-23	CAN -
C	FC6-24	CAN +

Dynamic Stability Control Module

	Pin	Description and Characteristic
C	FH103-11	CAN +
C	FH103-12	CAN +
C	FH103-13	CAN -
C	FH103-14	CAN -

Engine Control Module

	Pin	Description and Characteristic
SS	FH300-36	SPEED CONTROL SWITCH REQUEST: STEPPED RESISTANCE
I	FH300-35	SPEED CONTROL SWITCHES SIGNAL GROUND: GROUND
C	FH300-45	CAN -
C	FH300-58	CAN +

Instrument Cluster

	Pin	Description and Characteristic
C	FC9-12	CAN +
C	FC9-13	CAN -
C	FC9-28	CAN +
C	FC9-29	CAN -

COMPONENTS

Component	Connector(s)	Connector Description	Location
DYNAMIC STABILITY CONTROL MODULE	FH103	47-WAY / BLACK	ENGINE COMPARTMENT, RH FRONT
ENGINE CONTROL MODULE	FH300	58-WAY / BLACK	FRONT BULKHEAD, PASSENGER SIDE
	PI300	96-WAY / BLACK	FRONT BULKHEAD, PASSENGER SIDE
FUEL / TRUNK RELEASE SWITCH PACK	FC43	10-WAY / GREY	INSTRUMENT PANEL
INSTRUMENT CLUSTER	FC8	32-WAY / BLACK	INSTRUMENT PANEL
	FC9	32-WAY / BLACK	
SPEED CONTROL MODULE	FC6	30-WAY / YELLOW	INSTRUMENT PANEL, DRIVER SIDE
SPEED CONTROL SENSOR	CC1	5-WAY / BLACK	BELOW LH FRONT BUMPER
STEERING WHEEL	—	—	STEERING WHEEL
TRANSMISSION CONTROL MODULE	GB2	16-WAY / BLACK	TRANSMISSION CONTROL VALVE ASSEMBLY

HARNESS IN-LINE CONNECTORS

Connector	Connector Description / Location	Location
FC4	14-WAY / GREEN / FASCIA HARNESS IN-LINE CONNECTOR	BEHIND INSTRUMENT PANEL, LH SIDE
FC10	14-WAY / GREEN / FASCIA HARNESS TO FRONT HARNESS	BEHIND INSTRUMENT PANEL, RH SIDE
FC19	16-WAY / GREEN / CABIN HARNESS TO FASCIA HARNESS	BEHIND INSTRUMENT PANEL, LH SIDE
FC117	10-WAY / BLACK / STEERING WHEEL CASSETTE	STEERING COLUMN
FH1	22-WAY / DARK GREY / CABIN HARNESS TO FRONT HARNESS	RH 'A' POST, LOWER
FH90	6-WAY / GREY / SPEED SENSOR LINK HARNESS TO FRONT HARNESS	BELOW LH FRONT HEADLAMP ASSEMBLY

GROUNDS

Ground	Location
FC38	UNDER CENTER OF INSTRUMENT PANEL, ON TRANSMISSION TUNNEL
FH42	ENGINE COMPARTMENT, BEHIND RH HEADLAMP

FOR CONTROL MODULE PIN-OUT INFORMATION, UNFOLD PAGE TO LEFT.

The following abbreviations are used to represent values for Control Module Pin-Out data

I	Input	PG	Power Ground	C	CAN Network	D	Serial and Encoded Data
O	Output	SS	Sensor / Signal Supply V	S	SCP Network	V	Voltage (DC)
B+	Battery Voltage	SG	Sensor / Signal Ground	D2	D2B Network	PWM	Pulse Width Modulated

CAUTION: The information on this data page is furnished to aid the user in understanding circuit operation. THIS INFORMATION SHOULD BE USED FOR REFERENCE ONLY.

NOTE: The values listed are approximately those that can be expected at the control module connector pins with all circuit connections made and all components connected and fitted.

Refer to the front of this book for detailed information and illustrations regarding the location and identification of harnesses, relays, fuses, grounds, control modules and control module pins.

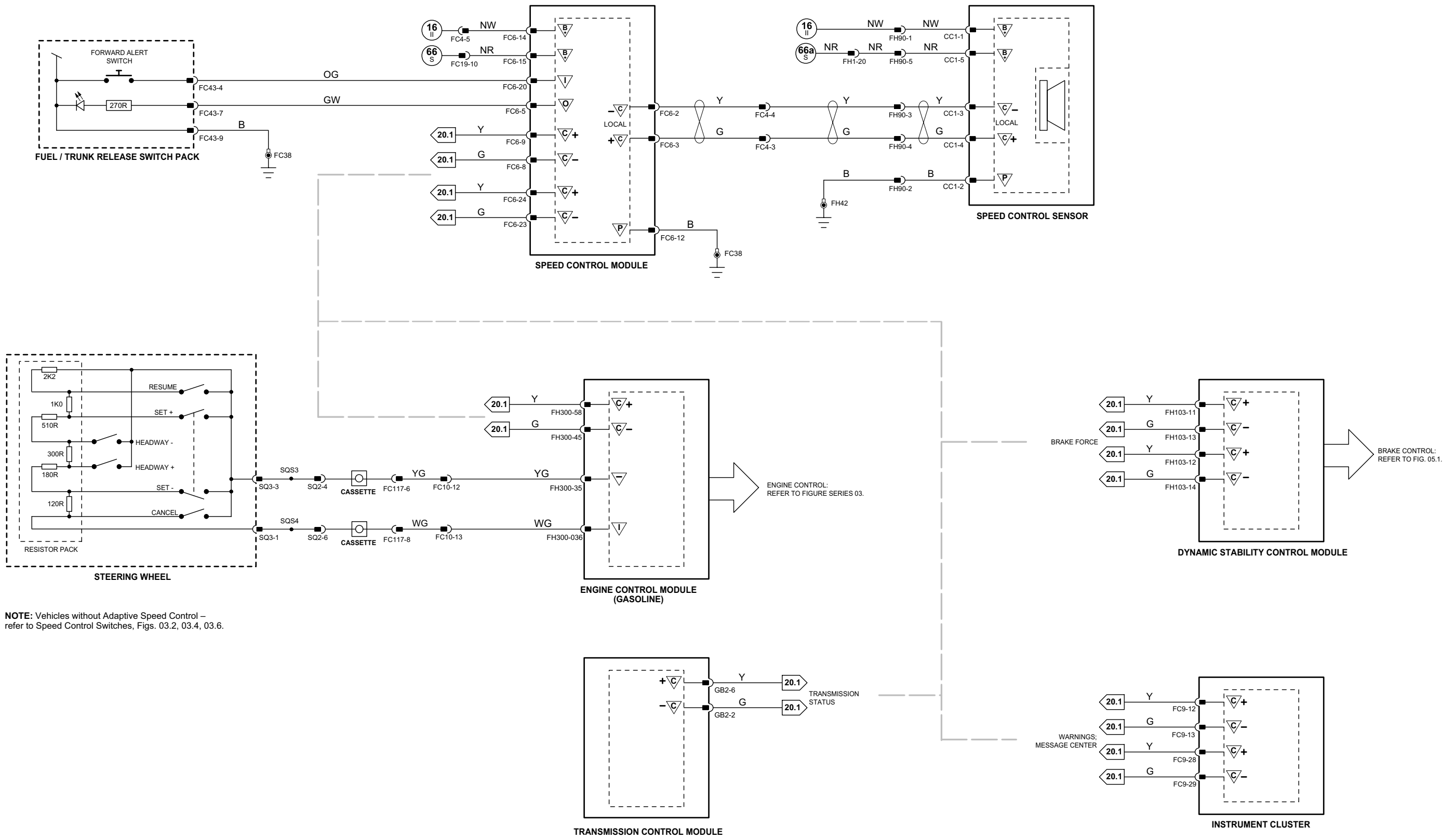

NOTE: Vehicles without Adaptive Speed Control – refer to Speed Control Switches, Figs. 03.2, 03.4, 03.6.

NOTE: Early production vehicles – Adaptive Speed Control not fitted.

Fig. 05.4

Adaptive Damping Control Module

	Pin	Description and Characteristic
O	CA11-1	RH REAR DAMPER SOLENOID DRIVE: PWM +
O	CA11-2	RH REAR DAMPER SOLENOID DRIVE: PWM -
O	CA11-3	LH REAR DAMPER SOLENOID DRIVE: PWM +
O	CA11-4	LH REAR DAMPER SOLENOID DRIVE: PWM -
O	CA11-5	LH FRONT DAMPER SOLENOID DRIVE: PWM -
O	CA11-6	LH FRONT DAMPER SOLENOID DRIVE: PWM +
O	CA11-7	RH FRONT DAMPER SOLENOID DRIVE: PWM -
O	CA11-8	RH FRONT DAMPER SOLENOID DRIVE: PWM +
SG	CA11-9	SIGNAL GROUND (INTERNALLY CONNECTED TO PIN 10): GROUND
PG	CA11-10	POWER GROUND: GROUND
B+	CA11-12	IGNITION SWITCHED POWER SUPPLY (II): B+
S	CA11-13	SCP -
S	CA11-14	SCP +
B+	CA11-16	BATTERY POWER SUPPLY: B+
SS	CA12-9	SENSOR SIGNAL SUPPLY VOLTAGE: NOMINAL 5 V
I	CA12-10	REAR VERTICAL ACCELEROMETER SIGNAL: SENSOR SIGNAL
I	CA12-11	LATERAL ACCELEROMETER SIGNAL: SENSOR SIGNAL
I	CA12-12	FRONT VERTICAL ACCELEROMETER SIGNAL: SENSOR SIGNAL

Dynamic Stability Control Module

	Pin	Description and Characteristic
C	FH103-11	CAN +
C	FH103-12	CAN +
C	FH103-13	CAN -
C	FH103-14	CAN -

Instrument Cluster

	Pin	Description and Characteristic
C	FC9-12	CAN +
C	FC9-13	CAN -
S	FC9-25	SCP +
S	FC9-26	SCP -
C	FC9-28	CAN +
C	FC9-29	CAN -

Rear Electronic Module

	Pin	Description and Characteristic
S	CA102-1	SCP +
S	CA102-2	SCP -

COMPONENTS

Component	Connector(s)	Connector Description	Location
ADAPTIVE DAMPING CONTROL MODULE	CA11	16-WAY / BLUE	LUGGAGE COMPARTMENT, REAR
	CA12	16-WAY / GREY	
DAMPER SOLENOID - LH FRONT	FH117	2-WAY BLACK	TOP OF LH FRONT DAMPER
DAMPER SOLENOID - LH REAR	CA140	2-WAY BLACK	TOP OF LH REAR DAMPER
DAMPER SOLENOID - RH FRONT	FH118	2-WAY BLACK	TOP OF RH FRONT DAMPER
DAMPER SOLENOID - RH REAR	CA111	2-WAY BLACK	TOP OF RH REAR DAMPER
DYNAMIC STABILITY CONTROL MODULE	FH103	47-WAY / BLACK	ENGINE COMPARTMENT, RH FRONT
INSTRUMENT CLUSTER	FC8	32-WAY / BLACK	INSTRUMENT PANEL
	FC9	32-WAY / BLACK	
LATERAL ACCELEROMETER	FH70	3-WAY / BLACK	REARWARD OF FRONT BUMPER, LH SIDE
REAR ELECTRONIC MODULE	CA63	17-WAY / BLACK	LUGGAGE COMPARTMENT, RH REAR
	CA100	12-WAY / BLACK	
	CA101	20-WAY / BLACK	
	CA102	22-WAY / BLACK	
	CA103	26-WAY / NATURAL	
VERTICAL ACCELEROMETER - FRONT	FH63	3-WAY / BLACK	REARWARD OF FRONT BUMPER, LH SIDE
VERTICAL ACCELEROMETER - REAR	CA17	3-WAY / BLACK	LUGGAGE COMPARTMENT, RH REAR

HARNESS IN-LINE CONNECTORS

Connector	Connector Description / Location	Location
FH2	16-WAY / GREY / CABIN HARNESS TO FRONT HARNESS	RH 'A' POST, LOWER
FH6	16-WAY GREEN / CABIN HARNESS TO FRONT HARNESS	LH 'A' POST, ADJACENT TO FEM

GROUNDS

Ground	Location
CA158	LUGGAGE COMPARTMENT, LH SIDE REAR CORNER

FOR CONTROL MODULE PIN-OUT INFORMATION, UNFOLD PAGE TO LEFT.

The following abbreviations are used to represent values for Control Module Pin-Out data

I	Input	PG	Power Ground	C	CAN Network	D	Serial and Encoded Data
O	Output	SS	Sensor / Signal Supply V	S	SCP Network	V	Voltage (DC)
B+	Battery Voltage	SG	Sensor / Signal Ground	D2	D2B Network	PWM	Pulse Width Modulated

CAUTION: The information on this data page is furnished to aid the user in understanding circuit operation. THIS INFORMATION SHOULD BE USED FOR REFERENCE ONLY.

NOTE: The values listed are approximately those that can be expected at the control module connector pins with all circuit connections made and all components connected and fitted.

Refer to the front of this book for detailed information and illustrations regarding the location and identification of harnesses, relays, fuses, grounds, control modules and control module pins.

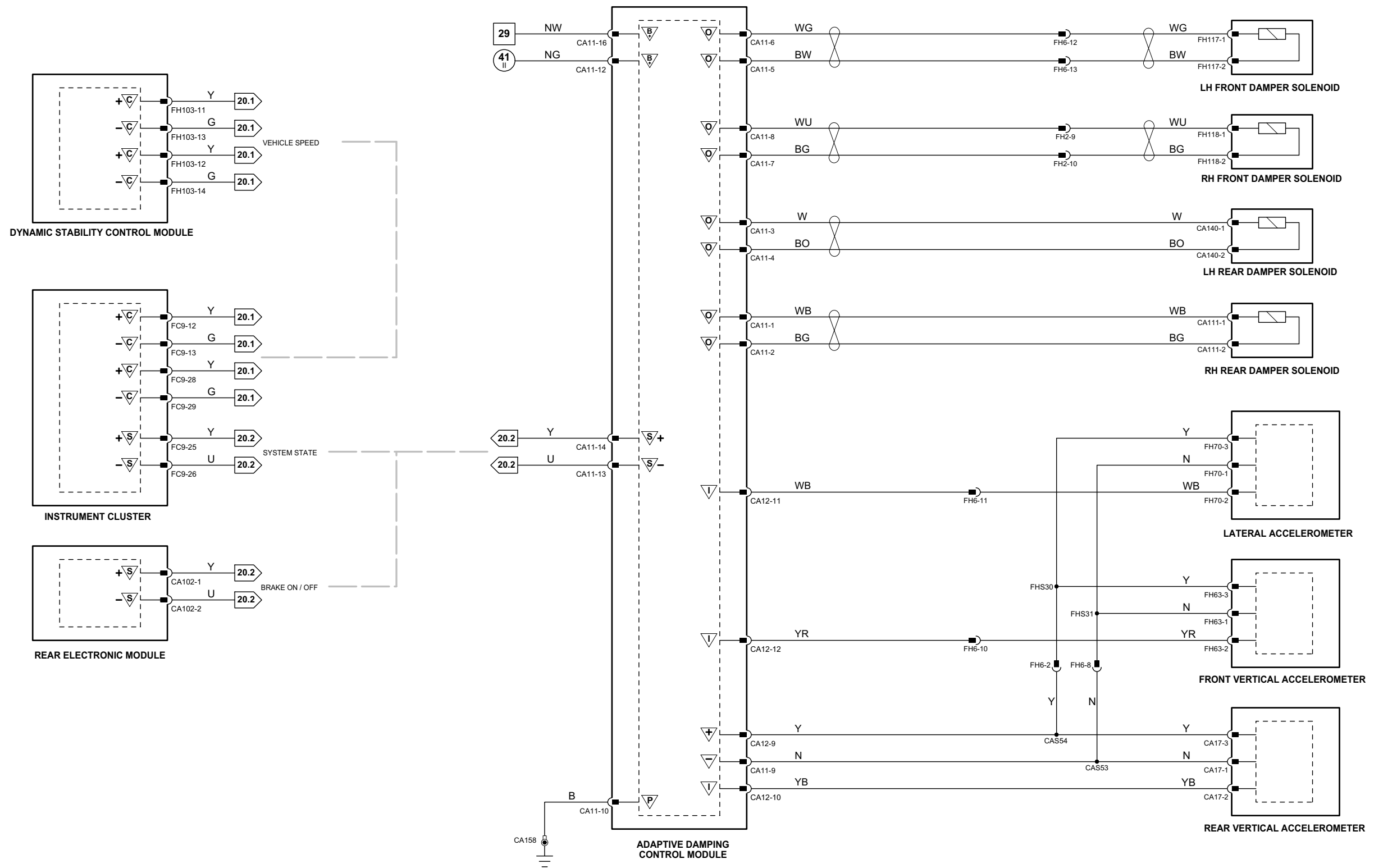

VARIANT: Adaptive Damping Vehicles
VIN RANGE: All
DATE OF ISSUE: April 2006

Air Conditioning Control Module – Panel

Pin	Description and Characteristic
I	FC27-1 DEFROST MODE ACTUATOR POSITION FEEDBACK: VARIABLE VOLTAGE
I	FC27-3 PANEL MODE ACTUATOR POSITION FEEDBACK: VARIABLE VOLTAGE
I	FC27-4 HUMIDITY SENSOR SIGNAL: VARIABLE VOLTAGE
O	FC27-5 DRIVER SIDE DUAL COOLANT CONTROL VALVE CONTROL DRIVE: ACTIVATE = GROUND (PWM)
O	FC27-6 PASSENGER SIDE DUAL COOLANT CONTROL VALVE CONTROL DRIVE: ACTIVATE = GROUND (PWM)
SS	FC27-7 HUMIDITY SENSOR SIGNAL SUPPLY VOLTAGE: NOMINAL 5 V
O	FC27-9 FRESH / RECIRCULATION ACTUATOR DRIVE – CLOSE: ACTIVATE = B+
O	FC27-10 FRESH / RECIRCULATION ACTUATOR DRIVE – OPEN: ACTIVATE = B+
O	FC27-13 DEFROST MODE ACTUATOR DRIVE – OPEN: ACTIVATE = B+
SG	FC27-14 IN-CAR TEMPERATURE SENSOR SIGNAL GROUND: GROUND
I	FC27-15 FRESH / RECIRCULATION ACTUATOR POSITION FEEDBACK: VARIABLE VOLTAGE
I	FC27-16 FLOOR MODE ACTUATOR POSITION FEEDBACK: VARIABLE VOLTAGE
SG	FC27-17 ACTUATOR SIGNAL GROUND: GROUND
O	FC27-18 AUXILIARY COOLANT PUMP RELAY ACTIVATE: TO ACTIVATE, A/CCM SWITCHES CIRCUIT TO GROUND
O	FC27-19 BLOWER MOTOR RELAY ACTIVATE: TO ACTIVATE, A/CCM SWITCHES CIRCUIT TO GROUND
O	FC27-20 HEATED WIPER PARK OR HEATED WINDSHIELD RELAY(S) ACTIVATE: TO ACTIVATE, A/CCM SWITCHES CIRCUIT TO GROUND
O	FC27-21 BLOWER MOTOR CONTROL: B+ (PWM)
O	FC27-22 FLOOR MODE ACTUATOR DRIVE – OPEN: ACTIVATE = B+
O	FC27-23 FLOOR MODE ACTUATOR DRIVE – CLOSE: ACTIVATE = B+
O	FC27-24 PANEL MODE ACTUATOR DRIVE – OPEN: ACTIVATE = B+
O	FC27-25 PANEL MODE ACTUATOR DRIVE – CLOSE: ACTIVATE = B+
O	FC27-26 DEFROST MODE ACTUATOR DRIVE – CLOSE: ACTIVATE = B+
C	FC28-1 CAN –
PG	FC28-2 POWER GROUND: GROUND
B+	FC28-3 IGNITION SWITCHED POWER SUPPLY (II): B+
I	FC28-5 BLOWER MOTOR CONTROL FEEDBACK: VARIABLE FREQUENCY
I	FC28-6 PASSENGER SIDE DISCHARGE TEMPERATURE SENSOR SIGNAL: NTC SENSOR / VOLTAGE DECREASES AS TEMPERATURE INCREASES
I	FC28-7 DUAL SOLAR SENSOR SIGNAL – LH: VOLTAGE DECREASES AS LIGHT INCREASES
SG	FC28-8 AMBIENT TEMPERATURE SENSOR SIGNAL GROUND: GROUND
I	FC28-9 IN-CAR TEMPERATURE SENSOR SIGNAL: NTC SENSOR / VOLTAGE DECREASES AS TEMPERATURE INCREASES
I	FC28-10 EVAPORATOR DISCHARGE TEMPERATURE SENSOR SIGNAL: NTC SENSOR / VOLTAGE DECREASES AS TEMPERATURE INCREASES
SG	FC28-11 ACTUATORS SIGNAL GROUND: GROUND
C	FC28-12 CAN
B+	FC28-14 BATTERY POWER SUPPLY: B+
I	FC28-15 PANEL ILLUMINATION (DIMMER-CONTROLLED): B+ (PWM)
SG	FC28-16 EVAPORATOR DISCHARGE TEMPERATURE SENSOR SIGNAL GROUND: GROUND
I	FC28-17 AMBIENT TEMPERATURE SENSOR SIGNAL: NTC SENSOR / VOLTAGE DECREASES AS TEMPERATURE INCREASES
I	FC28-18 DRIVER SIDE DISCHARGE TEMPERATURE SENSOR SIGNAL: NTC SENSOR / VOLTAGE DECREASES AS TEMPERATURE INCREASES
SG	FC28-19 LH / RH DISCHARGE TEMPERATURE SENSORS SIGNAL GROUND: GROUND
I	FC28-20 DUAL SOLAR SENSOR SIGNAL – RH: VOLTAGE DECREASES AS LIGHT INCREASES
SS	FC28-22 ACTUATORS SIGNAL SUPPLY VOLTAGE: NOMINAL 5 V

Air Conditioning Control Module – Remote

Pin	Description and Characteristic
I	FC40-1 DEFROST MODE ACTUATOR POSITION FEEDBACK: VARIABLE VOLTAGE
I	FC40-3 PANEL MODE ACTUATOR POSITION FEEDBACK: VARIABLE VOLTAGE
I	FC40-4 HUMIDITY SENSOR SIGNAL: VARIABLE VOLTAGE
O	FC40-5 DRIVER SIDE DUAL COOLANT CONTROL VALVE CONTROL DRIVE: ACTIVATE = GROUND (PWM)
O	FC40-6 PASSENGER SIDE DUAL COOLANT CONTROL VALVE CONTROL DRIVE: ACTIVATE = GROUND (PWM)
SS	FC40-7 HUMIDITY SENSOR SIGNAL SUPPLY VOLTAGE: NOMINAL 5 V
O	FC40-9 FRESH / RECIRCULATION ACTUATOR DRIVE – CLOSE: ACTIVATE = B+
O	FC40-10 FRESH / RECIRCULATION ACTUATOR DRIVE – OPEN: ACTIVATE = B+
O	FC40-13 DEFROST MODE ACTUATOR DRIVE – OPEN: ACTIVATE = B+
SG	FC40-14 IN-CAR TEMPERATURE SENSOR SIGNAL GROUND: GROUND
I	FC40-15 FRESH / RECIRCULATION ACTUATOR POSITION FEEDBACK: VARIABLE VOLTAGE
I	FC40-16 FLOOR MODE ACTUATOR POSITION FEEDBACK: VARIABLE VOLTAGE
SG	FC40-17 ACTUATOR SIGNAL GROUND: GROUND
O	FC40-18 AUXILIARY COOLANT PUMP RELAY ACTIVATE: TO ACTIVATE, A/CCM SWITCHES CIRCUIT TO GROUND
O	FC40-19 BLOWER MOTOR RELAY ACTIVATE: TO ACTIVATE, A/CCM SWITCHES CIRCUIT TO GROUND
O	FC40-20 HEATED WIPER PARK OR HEATED WINDSHIELD RELAY(S) ACTIVATE: TO ACTIVATE, A/CCM SWITCHES CIRCUIT TO GROUND
O	FC40-21 BLOWER MOTOR CONTROL: B+ (PWM)
O	FC40-22 FLOOR MODE ACTUATOR DRIVE – OPEN: ACTIVATE = B+
O	FC40-23 FLOOR MODE ACTUATOR DRIVE – CLOSE: ACTIVATE = B+
O	FC40-24 PANEL MODE ACTUATOR DRIVE – OPEN: ACTIVATE = B+
O	FC40-25 PANEL MODE ACTUATOR DRIVE – CLOSE: ACTIVATE = B+
O	FC40-26 DEFROST MODE ACTUATOR DRIVE – CLOSE: ACTIVATE = B+
C	FC41-1 CAN –
PG	FC41-2 POWER GROUND: GROUND
B+	FC41-3 IGNITION SWITCHED POWER SUPPLY (II): B+
I	FC41-5 BLOWER MOTOR CONTROL FEEDBACK: VARIABLE FREQUENCY
I	FC41-6 PASSENGER SIDE DISCHARGE TEMPERATURE SENSOR SIGNAL: NTC SENSOR / VOLTAGE DECREASES AS TEMPERATURE INCREASES
I	FC41-7 DUAL SOLAR SENSOR SIGNAL – LH: VOLTAGE DECREASES AS LIGHT INCREASES
SG	FC41-8 AMBIENT TEMPERATURE SENSOR SIGNAL GROUND: GROUND
I	FC41-9 IN-CAR TEMPERATURE SENSOR SIGNAL: NTC SENSOR / VOLTAGE DECREASES AS TEMPERATURE INCREASES
I	FC41-10 EVAPORATOR DISCHARGE TEMPERATURE SENSOR SIGNAL: NTC SENSOR / VOLTAGE DECREASES AS TEMPERATURE INCREASES
SG	FC41-11 ACTUATORS SIGNAL GROUND: GROUND
C	FC41-12 CAN +
B+	FC41-14 BATTERY POWER SUPPLY: B+
SG	FC41-16 EVAPORATOR DISCHARGE TEMPERATURE SENSOR SIGNAL GROUND: GROUND
I	FC41-17 AMBIENT TEMPERATURE SENSOR SIGNAL: NTC SENSOR / VOLTAGE DECREASES AS TEMPERATURE INCREASES
I	FC41-18 DRIVER SIDE DISCHARGE TEMPERATURE SENSOR SIGNAL: NTC SENSOR / VOLTAGE DECREASES AS TEMPERATURE INCREASES
SG	FC41-19 LH / RH DISCHARGE TEMPERATURE SENSORS SIGNAL GROUND: GROUND
I	FC41-20 DUAL SOLAR SENSOR SIGNAL – RH: VOLTAGE DECREASES AS LIGHT INCREASES
SS	FC41-22 ACTUATORS SIGNAL SUPPLY VOLTAGE: NOMINAL 5 V

The following abbreviations are used to represent values for Control Module Pin-Out data

I	Input	PG	Power Ground	C	CAN Network	D	Serial and Encoded Data
O	Output	SS	Sensor / Signal Supply V	S	SCP Network	V	Voltage (DC)
B+	Battery Voltage	SG	Sensor / Signal Ground	D2	D2B Network	PWM	Pulse Width Modulated

CAUTION: The information on this data page is furnished to aid the user in understanding circuit operation. THIS INFORMATION SHOULD BE USED FOR REFERENCE ONLY.

NOTE: The values listed are approximately those that can be expected at the control module connector pins with all circuit connections made and all components connected and fitted.

Fig. 06.1

COMPONENTS

Component	Connector(s)	Connector Description	Location
AIR CONDITIONING CONTROL MODULE – PANEL	FC27	26-WAY / GREY	CENTER CONSOLE
	FC28	22-WAY / GREY	
AIR CONDITIONING CONTROL MODULE – REMOTE	FC40	26-WAY / GREY	BEHIND INSTRUMENT PANEL, RH SIDE (LHD), LH SIDE (RHD)
	FC41	22-WAY / GREY	
AMBIENT TEMPERATURE SENSOR	FH30	2-WAY / BLACK	UNDER FRONT BUMPER, CENTER, FORWARD OF RADIATOR
AUXILIARY COOLANT PUMP (GASOLINE)	CP4	2-WAY / BLACK	ENGINE COMPARTMENT, BEHIND RADIATOR, LH SIDE
AUXILIARY COOLANT PUMP (DIESEL)	CP6	2-WAY / BLACK	ENGINE COMPARTMENT, BEHIND RADIATOR, LH SIDE
AUXILIARY COOLANT PUMP RELAY	—	—	FRONT POWER DISTRIBUTION FUSE BOX – R7
BLOWER MOTOR	AC2	6-WAY / BLACK	UNDER INSTRUMENT PANEL, RH SIDE (LHD), LH SIDE (RHD)
BLOWER MOTOR RELAY	—	—	REAR POWER DISTRIBUTION FUSE BOX – R7
DEFROST MODE ACTUATOR	FC29	6-WAY / BLACK	AIR DISTRIBUTION BOX
DISCHARGE TEMPERATURE SENSOR – EVAPORATOR	AC5	2-WAY / GREY	AIR DISTRIBUTION BOX
DISCHARGE TEMPERATURE SENSOR – LH	FC20	2-WAY BLACK	AIR DISTRIBUTION BOX
DISCHARGE TEMPERATURE SENSOR – RH	FC30	2-WAY BLACK	AIR DISTRIBUTION BOX
DUAL COOLANT CONTROL VALVE (GASOLINE)	CP5	3-WAY / BLACK	ENGINE COMPARTMENT, RH SIDE, REARWARD OF RADIATOR
DUAL COOLANT CONTROL VALVE (DIESEL)	FH34	3-WAY / BLACK	ENGINE COMPARTMENT, RH SIDE, REARWARD OF RADIATOR
DUAL SOLAR SENSOR	SL1	6-WAY / BLACK	INSTRUMENT PANEL GLARE SHIELD, FRONT CENTER
FLOOR MODE ACTUATOR	FC21	6-WAY / BLACK	AIR DISTRIBUTION BOX
FRESH / RECIRCULATION ACTUATOR	AC3	6-WAY / BLACK	BLOWER INTAKE
FRONT POWER DISTRIBUTION FUSE BOX	—	—	ENGINE COMPARTMENT, RH SIDE
HUMIDITY SENSOR	FC24	4-WAY / BLACK	INSTRUMENT PANEL, ADJACENT TO STEERING COLUMN
IN-CAR TEMPERATURE SENSOR	FC24	4-WAY / BLACK	INSTRUMENT PANEL, ADJACENT TO STEERING COLUMN
LH WINDSHIELD HEATER	CA122	1-WAY / BLACK	CONNECTORS LOCATED IN LH UPPER 'A' POST
	CA279	1-WAY / BLACK	
LH WINDSHIELD HEATER RELAY	—	—	FRONT POWER DISTRIBUTION FUSE BOX – R17
PANEL MODE ACTUATOR	FC22	6-WAY / BLACK	AIR DISTRIBUTION BOX
REAR POWER DISTRIBUTION FUSE BOX	—	—	LUGGAGE COMPARTMENT
WIPER PARK HEATER / RH WINDSHIELD HEATER RELAY	—	—	FRONT POWER DISTRIBUTION FUSE BOX – R21
WIPER PARK HEATER OR RH WINDSHIELD HEATER	CA65	1-WAY / BLACK	CONNECTORS LOCATED IN RH UPPER 'A' POST
	CA71	1-WAY / BLACK	

HARNESS IN-LINE CONNECTORS

Connector	Connector Description / Location	Location
AC7	2-WAY / GREY / CABIN HARNESS TO CLIMATE CONTROL HARNESS	BEHIND PASSENGER AIR BAG
CP1	10-WAY / BLACK / INTERCOOLER PUMP LINK LEAD	ENGINE COMPARTMENT, RH FRONT, ADJACENT TO RADIATOR
CP7	4-WAY / BLACK / COOLANT PUMP LINK LEAD	ENGINE COMPARTMENT, RH FRONT, ADJACENT TO RADIATOR
FC4	14-WAY / GREEN / FASCIA HARNESS IN-LINE CONNECTOR	BEHIND INSTRUMENT PANEL, LH SIDE
FC10	14-WAY / GREEN / FASCIA HARNESS TO FRONT HARNESS	BEHIND INSTRUMENT PANEL, RH SIDE
FC33	16-WAY / GREEN / CABIN HARNESS TO FASCIA HARNESS	BEHIND INSTRUMENT PANEL, RH SIDE
FC34	16-WAY / GREEN / FASCIA HARNESS IN-LINE CONNECTOR	ADJACENT TO BLOWER MOTOR
FH82	2-WAY / GREY / CABIN HARNESS TO FRONT HARNESS	RH 'A' POST
FH114	2-WAY / GREY / FRONT HARNESS TO CABIN HARNESS	BEHIND INSTRUMENT PANEL, LH SIDE
SL3	10-WAY / GREY / FASCIA HARNESS TO SOLAR SENSOR LINK	BEHIND INSTRUMENT PANEL, RH SIDE

GROUNDS

Ground	Location
CA30	LH LOWER 'A' POST, ADJACENT TO THE GENERAL ELECTRONIC CONTROL MODULE (REARWARD OF FH77)
CA50	RH LOWER 'A' POST, BELOW PRIMARY JUNCTION FUSE BOX
FC38	UNDER CENTER OF INSTRUMENT PANEL, ON TRANSMISSION TUNNEL
FH42	ENGINE COMPARTMENT, BEHIND RH HEADLAMP

FOR CONTROL MODULE PIN-OUT INFORMATION, UNFOLD PAGE TO LEFT.

Refer to the front of this book for detailed information and illustrations regarding the location and identification of harnesses, relays, fuses, grounds, control modules and control module pins.

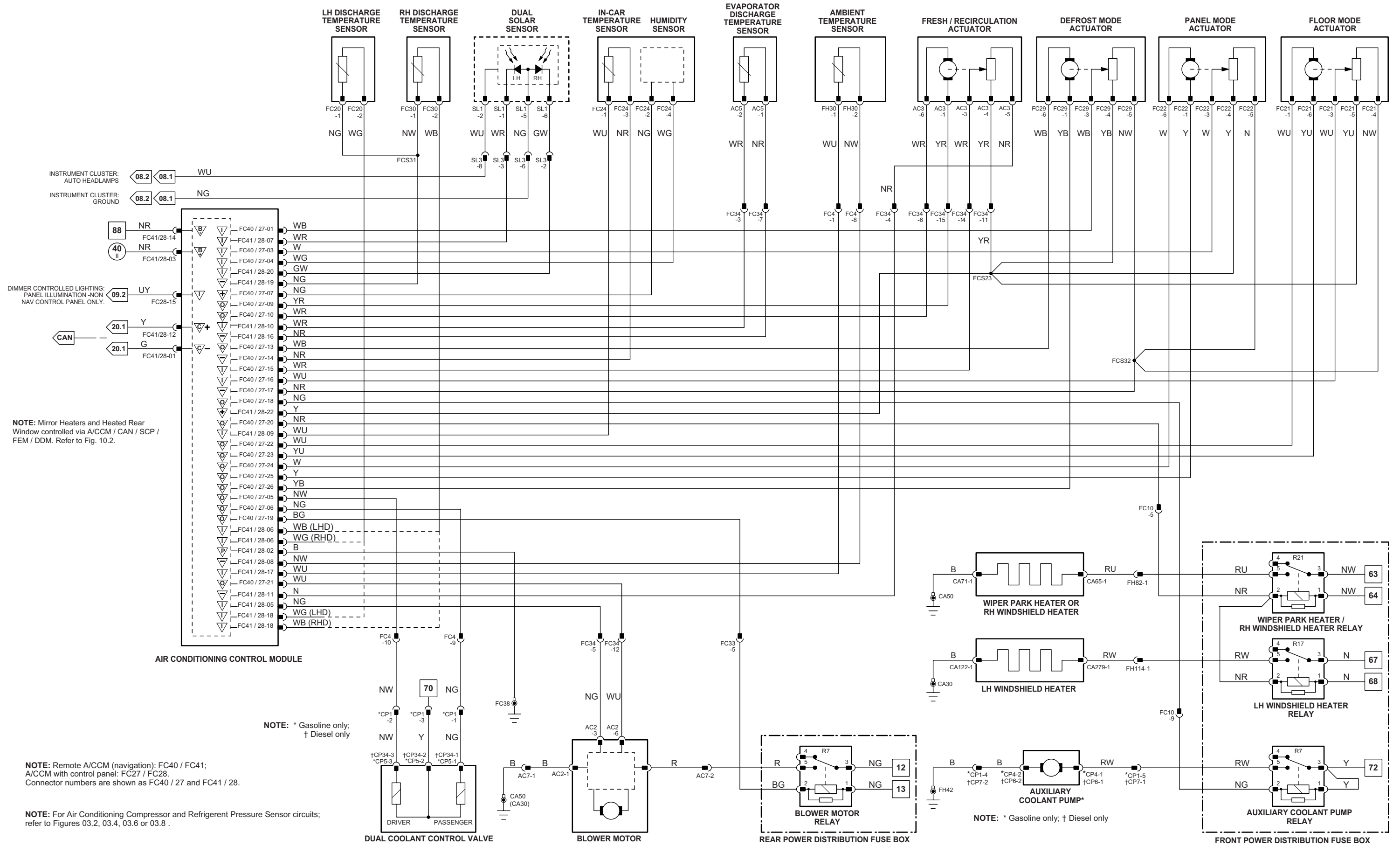

Front Electronic Module

	Pin	Description and Characteristic
I	FH9-15	WASHER FLUID LEVEL SWITCH (NORMALLY OPEN); OPEN CIRCUIT / GROUND
S	FH59-1	SCP -
B+	FH59-6	BATTERY POWER SUPPLY (LOGIC); B+
S	FH59-7	SCP +
I	FH59-9	ENGINE OIL PRESSURE SWITCH (NORMALLY OPEN); OPEN CIRCUIT / GROUND
PG	FH59-12	POWER GROUND: GROUND
PG	FH60-11	POWER GROUND: GROUND
PG	FH60-13	POWER GROUND: GROUND
PG	FH60-14	POWER GROUND: GROUND
PG	FH60-15	POWER GROUND: GROUND

Instrument Cluster

	Pin	Description and Characteristic
PG	FC8-2	POWER GROUND: GROUND
I	FC8-3	SEAT BELT AUDIBLE WARNING REQUEST: AUDIBLE WARNING REQUEST ACTIVE = GROUND
B+	FC8-4	IGNITION SWITCHED POWER SUPPLY (I); B+
I	FC8-5	KEY-IN AUDIBLE WARNING: B+ WHEN KEY IN
I	FC8-6	KEY-IN AUDIBLE WARNING (J-GATE); GROUND WHEN NOT-IN-PARK
B+	FC8-14	IGNITION SWITCHED POWER SUPPLY (II); B+
B+	FC8-15	BATTERY POWER SUPPLY (LOGIC); B+
SG	FC8-18	AUXILIARY LIGHTING SWITCH SIGNAL GROUND: GROUND
I	FC8-19	LOW ENGINE COOLANT LEVEL WARNING: GROUND WHEN COOLANT LEVEL LOW
I	FC8-23	AIR BAG WARNING: HARD-WIRED TO AIR BAG INDICATOR
B+	FC8-24	IGNITION SWITCHED POWER SUPPLY (II) (AIRBAG WARNING); B+
SG	FC8-32	SIGNAL GROUND: GROUND
I	FC9-1	TRIP COMPUTER - MESSAGE CENTER SIGNALS: VARIABLE RESISTANCE
SG	FC9-10	MAIN LIGHTING SWITCH SIGNAL GROUND: GROUND
C	FC9-12	CAN +
C	FC9-13	CAN -
I	FC9-17	TRIP CYCLE SWITCH - MESSAGE CENTER SIGNAL: VARIABLE RESISTANCE
S	FC9-25	SCP +
S	FC9-26	SCP -
C	FC9-28	CAN +
C	FC9-29	CAN -

Rear Electronic Module

	Pin	Description and Characteristic
B+	CA101-3	BATTERY POWER SUPPLY: B+
I	CA101-15	GASOLINE, RH FUEL LEVEL SENSOR SIGNAL: VARIABLE RESISTANCE
I	CA101-16	GASOLINE, LH FUEL LEVEL SENSOR SIGNAL: VARIABLE RESISTANCE
S	CA102-1	SCP +
S	CA102-2	SCP -
PG	CA102-12	POWER GROUND: GROUND
I	CA102-17	LOW LEVEL SWITCH
I	CA102-20	LOW LEVEL SWITCH
PG	CA103-11	POWER GROUND: GROUND
PG	CA103-12	POWER GROUND: GROUND
I	CA103-15	DIESEL, RH FUEL LEVEL SENSOR SIGNAL: VARIABLE RESISTANCE
I	CA103-16	DIESEL, LH FUEL LEVEL SENSOR SIGNAL: VARIABLE RESISTANCE
SG	CA103-23	FUEL LEVEL SENSORS SIGNAL GROUND: GROUND
PG	CA103-25	POWER GROUND: GROUND
PG	CA103-26	POWER GROUND: GROUND

The following abbreviations are used to represent values for Control Module Pin-Out data

I	Input	PG	Power Ground	C	CAN Network	D	Serial and Encoded Data
O	Output	SS	Sensor / Signal Supply V	S	SCP Network	V	Voltage (DC)
B+	Battery Voltage	SG	Sensor / Signal Ground	D2	D2B Network	PWM	Pulse Width Modulated

CAUTION: The information on this data page is furnished to aid the user in understanding circuit operation. THIS INFORMATION SHOULD BE USED FOR REFERENCE ONLY.

NOTE: The values listed are approximately those that can be expected at the control module connector pins with all circuit connections made and all components connected and fitted.

Fig. 07.1

COMPONENTS

Component	Connector(s)	Connector Description	Location
AUXILIARY LIGHTING SWITCH	FC11	10-WAY / YELLOW	FASCIA, ADJACENT TO STEERING COLUMN
ENGINE COOLANT LEVEL SENSOR	CP3	2-WAY / BLACK	ENGINE COMPARTMENT, COOLANT EXPANSION TANK
FRONT ELECTRONIC MODULE	CA24	26-WAY / NATURAL	LH 'A' POST
	CA31	20-WAY / BLACK	
	FH9	22-WAY / BLACK	
	FH59	12-WAY / BLACK	
	FH60	17-WAY / BLACK	
FUEL LEVEL SENSOR - LH SIDE (DIESEL)	FP14	2-WAY / BLACK	FUEL TANK, LH SIDE
FUEL LEVEL SENSOR - RH SIDE (DIESEL)	FP13	6-WAY / GREY	FUEL TANK, RH SIDE
FUEL LEVEL SENSORS - (GASOLINE)	FP16	6-WAY / BLACK	FUEL TANK
FUEL LOW LEVEL SWITCH (DIESEL)	FP13	6-WAY / GREY	FUEL TANK, RH SIDE
IGNITION SWITCH	FC18	7-WAY / BLACK	STEERING COLUMN COWLING
INSTRUMENT CLUSTER	FC8	32-WAY / BLACK	INSTRUMENT PANEL
	FC9	32-WAY / BLACK	
OIL PRESSURE SWITCH (GASOLINE)	PI46	1-WAY / BLACK	ADJACENT TO OIL FILTER
OIL PRESSURE SWITCH (DIESEL)	C29	1-WAY / BLACK	ADJACENT TO OIL FILTER
REAR ELECTRONIC MODULE	CA63	17-WAY / BLACK	LUGGAGE COMPARTMENT, RH REAR
	CA100	12-WAY / BLACK	
	CA101	20-WAY / BLACK	
	CA102	22-WAY / BLACK	
	CA103	26-WAY / NATURAL	
TRIP CYCLE SWITCH (COLUMN SWITCHGEAR)	FC116	6-WAY / BLACK	STEERING COLUMN COWLING
WASHER FLUID LEVEL SWITCH	FH37	2-WAY / BLACK	WASHER FLUID CONTAINER

HARNESS IN-LINE CONNECTORS

Connector	Connector Description / Location	Location
CP1	10-WAY / BLACK / INTERCOOLER PUMP LINK LEAD	ENGINE COMPARTMENT, RH FRONT, ADJACENT TO RADIATOR
CP7	4-WAY / BLACK / FRONT END HARNESS	ENGINE COMPARTMENT, RH FRONT, ADJACENT TO RADIATOR
FC4	14-WAY / GREEN / FASCIA HARNESS IN-LINE CONNECTOR	BEHIND INSTRUMENT PANEL, LH SIDE
FC26	16-WAY / BLUE / CABIN HARNESS TO FASCIA HARNESS	BEHIND INSTRUMENT PANEL, DRIVER SIDE
FP2	8-WAY / BLACK / CABIN HARNESS TO FUEL PUMP HARNESS	TOP OF FUEL TANK, RH SIDE
FP4	8-WAY / GREY / FUEL TANK HARNESS TO VEHICLE HARNESS	BIW ABOVE FUEL TANK, RH SIDE
FP17	3-WAY / BLACK / VEHICLE HARNESS TO FUEL TANK HARNESS	BIW ABOVE FUEL TANK
PI41	42-WAY / BLACK / ENGINE HARNESS TO VEHICLE HARNESSES	ENGINE COMPARTMENT, BULKHEAD, PASSENGER SIDE

GROUNDS

Ground	Location
CA156	LUGGAGE COMPARTMENT, RH SIDE
FC38	UNDER CENTER OF INSTRUMENT PANEL, ON TRANSMISSION TUNNEL
FH42	ENGINE COMPARTMENT, BEHIND RH HEADLAMP
FH77	LH LOWER 'A' POST, ADJACENT TO THE FRONT ELECTRONIC MODULE (FORWARD OF CA30)

FOR CONTROL MODULE PIN-OUT INFORMATION, UNFOLD PAGE TO LEFT.

Refer to the front of this book for detailed information and illustrations regarding the location and identification of harnesses, relays, fuses, grounds, control modules and control module pins.

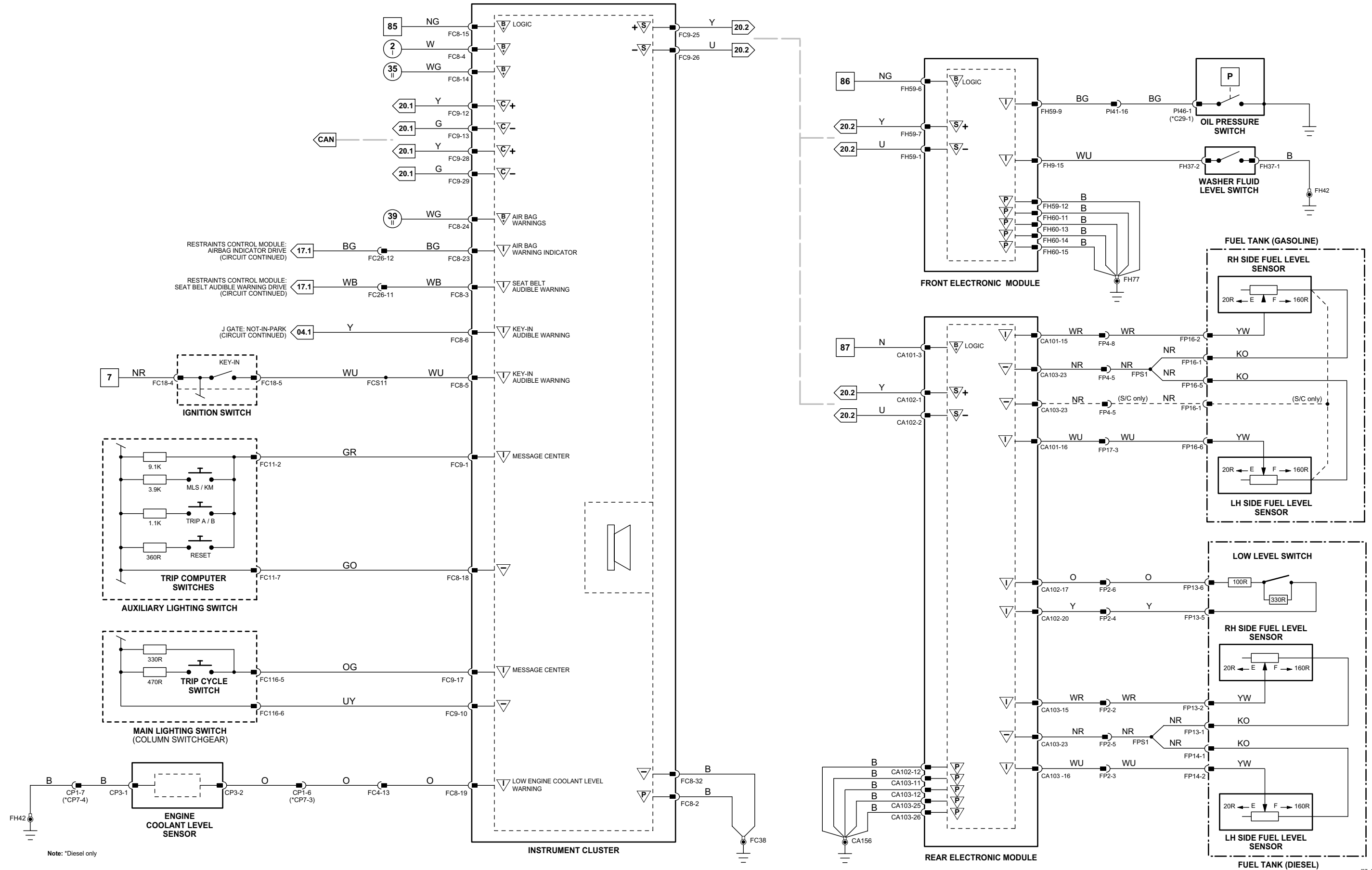

Note: *Diesel only

- 1 → 3 Fig. 01.1
- 4 → 76 Fig. 01.2
- 77 → 92 Fig. 01.3
- 1 → 14 Fig. 01.4
- 15 → 45 Fig. 01.5
- 46 → 80 Fig. 01.6
- 81 → 118 Fig. 01.7
- Input
- Battery Voltage
- Sensor/Signal Supply V
- Output
- Power Ground
- Sensor/Signal Ground
- CAN
- D2B Network
- SCP
- Serial and Encoded Data

VARIANT: All Vehicles
 VIN RANGE: All
 DATE OF ISSUE: April 2006

Front Electronic Module

Pin	Description and Characteristic
O	FH9-7 LH TURN SIGNAL REPEATER LAMP ACTIVATE: TO ACTIVATE, FEM SWITCHES CIRCUIT TO GROUND (PULSED)
O	FH9-11 RH SIDE MARKER LAMP ACTIVATE: TO ACTIVATE, FEM SWITCHES CIRCUIT TO GROUND
O	FH9-19 RH TURN SIGNAL REPEATER LAMP ACTIVATE: TO ACTIVATE, FEM SWITCHES CIRCUIT TO GROUND (PULSED)
O	FH9-22 LH SIDE MARKER LAMP ACTIVATE: TO ACTIVATE, FEM SWITCHES CIRCUIT TO GROUND
S	FH59-1 SCP -
O	FH59-2 LH FRONT SIDE LAMP ACTIVATE: TO ACTIVATE, FEM SWITCHES CIRCUIT TO GROUND
O	FH59-5 FRONT FOG LAMP RELAY ACTIVATE: TO ACTIVATE, FEM SWITCHES CIRCUIT TO GROUND
B+	FH59-6 BATTERY POWER SUPPLY (LOGIC): B+
S	FH59-7 SCP +
O	FH59-10 RH FRONT SIDE LAMP ACTIVATE: TO ACTIVATE, FEM SWITCHES CIRCUIT TO GROUND
PG	FH59-12 POWER GROUND: GROUND
O	FH60-4 RH FRONT TURN SIGNAL ACTIVATE: TO ACTIVATE, FEM SWITCHES CIRCUIT TO GROUND (PULSED)
O	FH60-5 LH FRONT TURN SIGNAL ACTIVATE: TO ACTIVATE, FEM SWITCHES CIRCUIT TO GROUND (PULSED)
O	FH60-7 RH DIP BEAM ACTIVATE: TO ACTIVATE, FEM SWITCHES CIRCUIT TO GROUND
O	FH60-8 LH DIP BEAM ACTIVATE: TO ACTIVATE, FEM SWITCHES CIRCUIT TO GROUND
O	FH60-10 RH MAIN BEAM ACTIVATE: TO ACTIVATE, FEM SWITCHES CIRCUIT TO GROUND
PG	FH60-11 POWER GROUND: GROUND
PG	FH60-13 POWER GROUND: GROUND
PG	FH60-14 POWER GROUND: GROUND
PG	FH60-15 POWER GROUND: GROUND
O	FH60-17 LH MAIN BEAM ACTIVATE: TO ACTIVATE, FEM SWITCHES CIRCUIT TO GROUND

Instrument Cluster

Pin	Description and Characteristic
PG	FC8-2 POWER GROUND: GROUND
B+	FC8-15 BATTERY POWER SUPPLY (LOGIC): B+
SG	FC8-18 AUXILIARY LIGHTING SWITCH SIGNAL GROUND: GROUND
O	FC8-22 HAZARD INDICATOR: PULSED B+
SG	FC8-32 SIGNAL GROUND: GROUND
I	FC9-2 MAIN LIGHTING SWITCH SIGNALS - OFF, SIDE, DIP, AUTOLAMP: VARIABLE RESISTANCE
I	FC9-3 MAIN LIGHTING SWITCH SIGNALS - MAIN, FLASH: VARIABLE RESISTANCE
I	FC9-5 MAIN LIGHTING SWITCH SIGNALS - EXIT DELAY: VARIABLE RESISTANCE
I	FC9-6 MAIN LIGHTING SWITCH SIGNALS - TURN SIGNALS, HAZARD WARNING: TURN = VARIABLE RESISTANCE; HAZARD = GROUND
I	FC9-7 AUTOLAMP SENSOR SIGNAL: VARIABLE RESISTANCE
I	FC9-8 FOG LAMPS SWITCH SIGNAL: VARIABLE RESISTANCE
SG	FC9-9 AUTOLAMP SENSOR GROUND: GROUND
SG	FC9-10 MAIN LIGHTING SWITCH SIGNAL GROUND: GROUND
S	FC9-25 SCP +
S	FC9-26 SCP -

The following abbreviations are used to represent values for Control Module Pin-Out data

I	Input	PG	Power Ground	C	CAN Network	D	Serial and Encoded Data
O	Output	SS	Sensor / Signal Supply V	S	SCP Network	V	Voltage (DC)
B+	Battery Voltage	SG	Sensor / Signal Ground	D2	D2B Network	PWM	Pulse Width Modulated

CAUTION: The information on this data page is furnished to aid the user in understanding circuit operation. THIS INFORMATION SHOULD BE USED FOR REFERENCE ONLY.

NOTE: The values listed are approximately those that can be expected at the control module connector pins with all circuit connections made and all components connected and fitted.

Fig. 08.1

COMPONENTS

Component	Connector(s)	Connector Description	Location
AUXILIARY LIGHTING SWITCH	FC11	10-WAY / YELLOW	FASCIA, ADJACENT TO STEERING COLUMN
CENTER CONSOLE SWITCH PACK	FC113	8-WAY / BLACK	CENTER CONSOLE
	FC119	8-WAY / BLACK	
DUAL SOLAR SENSOR (AUTO HEADLAMP)	SL1	6-WAY / BLACK	INSTRUMENT PANEL GLARE SHIELD, FRONT CENTER
FRONT ELECTRONIC MODULE	CA24	26-WAY / NATURAL	LH 'A' POST
	CA31	20-WAY / BLACK	
	FH9	22-WAY / BLACK	
	FH59	12-WAY / BLACK	
	FH60	17-WAY / BLACK	
FRONT FOG LAMP - LH	BF4	2-WAY / BLACK	FRONT BUMPER, LH SIDE
FRONT FOG LAMP - RH	BF5	2-WAY / BLACK	FRONT BUMPER, RH SIDE
FRONT FOG LAMP RELAY	—	—	FRONT POWER DISTRIBUTION FUSE BOX - R11
FRONT POWER DISTRIBUTION FUSE BOX	—	—	ENGINE COMPARTMENT, RH SIDE
HEADLAMP UNIT - LH	HL2	2-WAY / BLACK	ENGINE COMPARTMENT, LH FRONT
	HL3	2-WAY / BLACK	
	HL4	2-WAY / BLACK	
	HL7	3-WAY / GREY	
	HL8	2-WAY / BLACK	
HEADLAMP UNIT - RH	HR2	2-WAY / BLACK	ENGINE COMPARTMENT, RH FRONT
	HR3	2-WAY / BLACK	
	HR4	2-WAY / BLACK	
	HR7	3-WAY / GREY	
	HR8	2-WAY / BLACK	
INSTRUMENT CLUSTER	FC8	32-WAY / BLACK	INSTRUMENT PANEL
	FC9	32-WAY / BLACK	
MAIN LIGHTING SWITCH (COLUMN SWITCHGEAR)	FC116	6-WAY / BLACK	STEERING COLUMN COWLING
SIDE MARKER - LH	BF2	2-WAY / BLACK	FRONT BUMPER, LH SIDE
SIDE MARKER - RH	BF3	2-WAY / BLACK	FRONT BUMPER, RH SIDE
TURN REPEATER - LH	FH62	2-WAY / BLACK	LH FRONT FENDER
TURN REPEATER - RH	FH76	2-WAY / BLACK	RH FRONT FENDER

HARNESS IN-LINE CONNECTORS

Connector	Connector Description / Location	Location
BF1	6-WAY / GREY / FRONT HARNESS TO FRONT BUMPER HARNESS	BEHIND FRONT BUMPER, LH SIDE
FH39	12-WAY / GREY / FRONT HARNESS TO RH FRONT HEADLAMP LINK	BEHIND FRONT BUMPER, RH SIDE
FH40	12-WAY / GREY / FRONT HARNESS TO LH FRONT HEADLAMP LINK	BEHIND FRONT BUMPER, LH SIDE
SL3	10-WAY / GREY / FASCIA HARNESS TO SOLAR SENSOR LINK	BEHIND INSTRUMENT PANEL, RH SIDE

GROUNDS

Ground	Location
FC38	UNDER CENTER OF INSTRUMENT PANEL, ON TRANSMISSION TUNNEL
FH22	ENGINE COMPARTMENT, BEHIND LH HEADLAMP
FH77	LH LOWER 'A' POST, ADJACENT TO THE FRONT ELECTRONIC MODULE (FORWARD OF CA30)

FOR CONTROL MODULE PIN-OUT INFORMATION, UNFOLD PAGE TO LEFT.

Refer to the front of this book for detailed information and illustrations regarding the location and identification of harnesses, relays, fuses, grounds, control modules and control module pins.

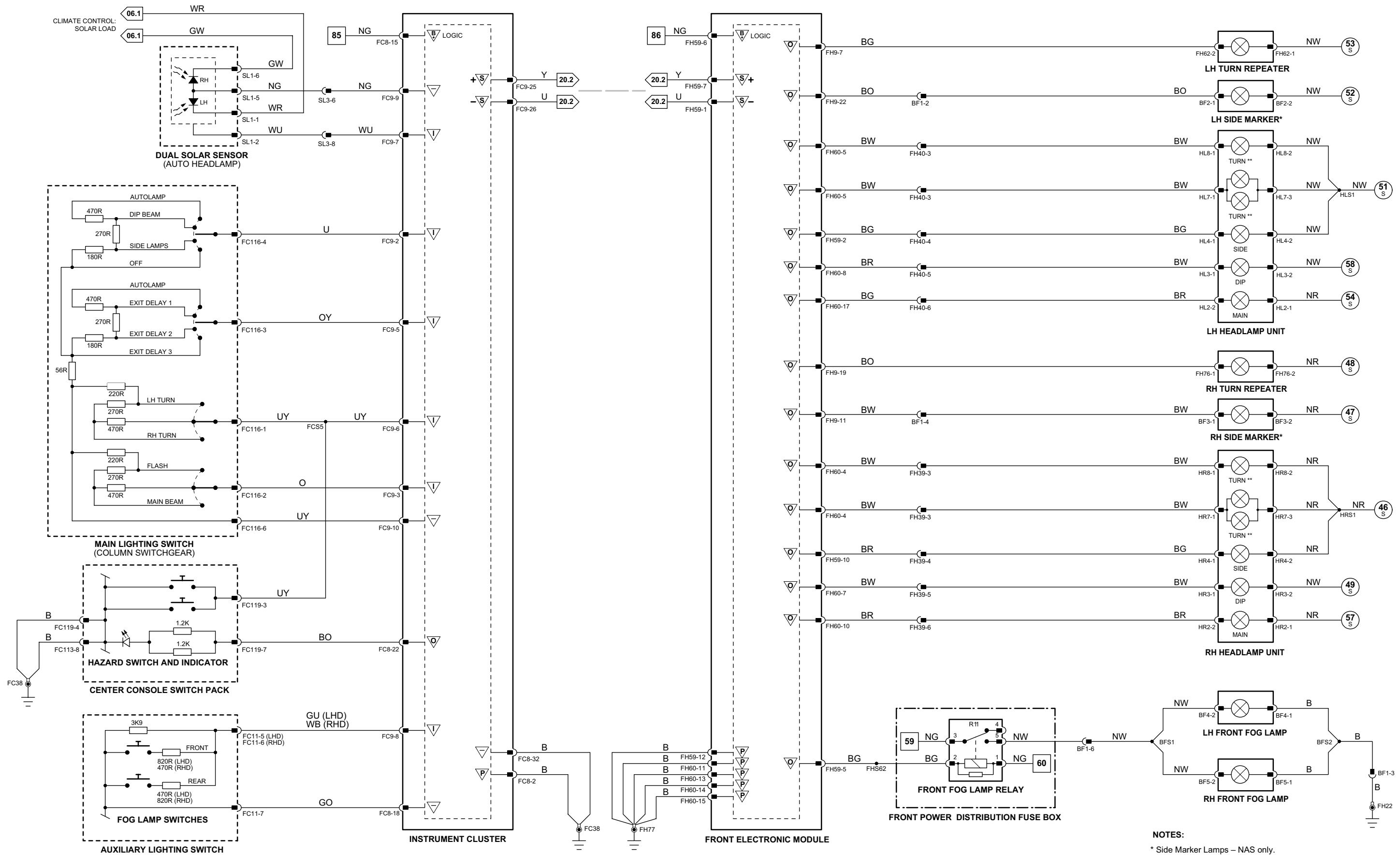

NOTES:
 * Side Marker Lamps – NAS only.
 ** Either single or dual filament turn signals fitted.

1 → 3	4 → 76	77 → 92	1 → 14	15 → 45	46 → 80	81 → 118	Input	Battery Voltage	Sensor/Signal Supply V	CAN	D2B Network
Fig. 01.1	Fig. 01.2	Fig. 01.3	Fig. 01.4	Fig. 01.5	Fig. 01.6	Fig. 01.7	Output	Power Ground	Sensor/Signal Ground	SCP	Serial and Encoded Data

VARIANT: Non HID Headlamp Vehicles
VIN RANGE: All
DATE OF ISSUE: April 2006

Front Electronic Module

Pin	Description and Characteristic
O CA31-20	RH HID RELAY ACTIVATE: TO ACTIVATE, FEM SWITCHES CIRCUIT TO GROUND
O FH9-6	LH HID RELAY ACTIVATE: TO ACTIVATE, FEM SWITCHES CIRCUIT TO GROUND
O FH9-7	LH TURN SIGNAL REPEATER LAMP ACTIVATE: TO ACTIVATE, FEM SWITCHES CIRCUIT TO GROUND (PULSED)
O FH9-11	RH SIDE MARKER LAMP ACTIVATE: TO ACTIVATE, FEM SWITCHES CIRCUIT TO GROUND
O FH9-19	RH TURN SIGNAL REPEATER LAMP ACTIVATE: TO ACTIVATE, FEM SWITCHES CIRCUIT TO GROUND (PULSED)
O FH9-22	LH SIDE MARKER LAMP ACTIVATE: TO ACTIVATE, FEM SWITCHES CIRCUIT TO GROUND
S FH59-1	SCP -
O FH59-2	LH FRONT SIDE LAMP ACTIVATE: TO ACTIVATE, FEM SWITCHES CIRCUIT TO GROUND
O FH59-5	FRONT FOG LAMP RELAY ACTIVATE: TO ACTIVATE, FEM SWITCHES CIRCUIT TO GROUND
B+ FH59-6	BATTERY POWER SUPPLY (LOGIC): B+
S FH59-7	SCP +
O FH59-10	RH FRONT SIDE LAMP ACTIVATE: TO ACTIVATE, FEM SWITCHES CIRCUIT TO GROUND
PG FH59-12	POWER GROUND: GROUND
O FH60-4	RH FRONT TURN SIGNAL ACTIVATE: TO ACTIVATE, FEM SWITCHES CIRCUIT TO GROUND (PULSED)
O FH60-5	LH FRONT TURN SIGNAL ACTIVATE: TO ACTIVATE, FEM SWITCHES CIRCUIT TO GROUND (PULSED)
O FH60-10	RH MAIN BEAM ACTIVATE: TO ACTIVATE, FEM SWITCHES CIRCUIT TO GROUND
PG FH60-11	POWER GROUND: GROUND
PG FH60-13	POWER GROUND: GROUND
PG FH60-14	POWER GROUND: GROUND
PG FH60-15	POWER GROUND: GROUND
O FH60-17	LH MAIN BEAM ACTIVATE: TO ACTIVATE, FEM SWITCHES CIRCUIT TO GROUND

Instrument Cluster

Pin	Description and Characteristic
PG FC8-2	POWER GROUND: GROUND
B+ FC8-15	BATTERY POWER SUPPLY (LOGIC): B+
SG FC8-18	AUXILIARY LIGHTING SWITCH SIGNAL GROUND: GROUND
O FC8-22	HAZARD INDICATOR: PULSED B+
SG FC8-32	SIGNAL GROUND: GROUND
I FC9-2	MAIN LIGHTING SWITCH SIGNALS - OFF, SIDE, DIP, AUTOLAMP: VARIABLE RESISTANCE
I FC9-3	MAIN LIGHTING SWITCH SIGNALS - MAIN, FLASH: VARIABLE RESISTANCE
I FC9-5	MAIN LIGHTING SWITCH SIGNALS - EXIT DELAY: VARIABLE RESISTANCE
I FC9-6	MAIN LIGHTING SWITCH SIGNALS - TURN SIGNALS, HAZARD WARNING: TURN = VARIABLE RESISTANCE; HAZARD = GROUND
I FC9-7	AUTOLAMP SENSOR SIGNAL: VARIABLE RESISTANCE
I FC9-8	FOG LAMPS SWITCH SIGNAL: VARIABLE RESISTANCE
SG FC9-9	AUTOLAMP SENSOR GROUND: GROUND
SG FC9-10	MAIN LIGHTING SWITCH SIGNAL GROUND: GROUND
S FC9-25	SCP +
S FC9-26	SCP -

Fig. 08.2

COMPONENTS

Component	Connector(s)	Connector Description	Location
AUXILIARY LIGHTING SWITCH	FC11	10-WAY / YELLOW	FASCIA, ADJACENT TO STEERING COLUMN
CENTER CONSOLE SWITCH PACK	FC113 FC119	8-WAY / BLACK 8-WAY / BLACK	CENTER CONSOLE
DUAL SOLAR SENSOR (AUTO HEADLAMP)	SL1	6-WAY / BLACK	INSTRUMENT PANEL GLARE SHIELD, FRONT CENTER
FRONT ELECTRONIC MODULE	CA24 CA31 FH9 FH59 FH60	26-WAY / NATURAL 20-WAY / BLACK 22-WAY / BLACK 12-WAY / BLACK 17-WAY / BLACK	LH 'A' POST
FRONT FOG LAMP - LH	BF4	2-WAY / BLACK	FRONT BUMPER, LH SIDE
FRONT FOG LAMP - RH	BF5	2-WAY / BLACK	FRONT BUMPER, RH SIDE
FRONT FOG LAMP RELAY	-	-	FRONT POWER DISTRIBUTION FUSE BOX - R11
FRONT POWER DISTRIBUTION FUSE BOX	-	-	ENGINE COMPARTMENT, RH SIDE
HEADLAMP UNIT - LH	HL2 HL3 HL4 HL6 (HID) HL7 HL8	2-WAY / BLACK 2-WAY / BLACK 2-WAY / BLACK 2-WAY / WHITE 3-WAY / GREY 2-WAY / BLACK	ENGINE COMPARTMENT, LH FRONT
HEADLAMP UNIT - RH	HR2 HR3 HR4 HR6 (HID) HR7 HR8	2-WAY / BLACK 2-WAY / BLACK 2-WAY / BLACK 2-WAY / WHITE 3-WAY / GREY 2-WAY / BLACK	ENGINE COMPARTMENT, RH FRONT
HID RELAY - LH	-	-	FRONT POWER DISTRIBUTION FUSE BOX - R10
HID RELAY - RH	-	-	FRONT POWER DISTRIBUTION FUSE BOX - R13
INSTRUMENT CLUSTER	FC8 FC9	32-WAY / BLACK 32-WAY / BLACK	INSTRUMENT PANEL
MAIN LIGHTING SWITCH (COLUMN SWITCHGEAR)	FC116	6-WAY / BLACK	STEERING COLUMN COWLING
SIDE MARKER - LH	BF2	2-WAY / BLACK	FRONT BUMPER, LH SIDE
SIDE MARKER - RH	BF3	2-WAY / BLACK	FRONT BUMPER, RH SIDE
TURN REPEATER - LH	FH62	2-WAY / BLACK	LH FRONT FENDER
TURN REPEATER - RH	FH76	2-WAY / BLACK	RH FRONT FENDER

HARNES IN-LINE CONNECTORS

Connector	Connector Description / Location	Location
BF1	6-WAY / GREY / FRONT HARNESS TO FRONT BUMPER HARNESS	BEHIND FRONT BUMPER, LH SIDE
FH6	16-WAY GREEN / CABIN HARNESS TO FRONT HARNESS	LH 'A' POST, ADJACENT TO FEM
FH39	12-WAY / GREY / FRONT HARNESS TO RH FRONT HEADLAMP LINK	BEHIND FRONT BUMPER, RH SIDE
FH40	12-WAY / GREY / FRONT HARNESS TO LH FRONT HEADLAMP LINK	BEHIND FRONT BUMPER, LH SIDE
SL3	10-WAY / GREY / FASCIA HARNESS TO SOLAR SENSOR LINK	BEHIND INSTRUMENT PANEL, RH SIDE

GROUNDS

Ground	Location
FC38	UNDER CENTER OF INSTRUMENT PANEL, ON TRANSMISSION TUNNEL
FH22	ENGINE COMPARTMENT, BEHIND LH HEADLAMP
FH42	ENGINE COMPARTMENT, BEHIND RH HEADLAMP
FH77	LH LOWER 'A' POST, ADJACENT TO THE FRONT ELECTRONIC MODULE (FORWARD OF CA30)

FOR CONTROL MODULE PIN-OUT INFORMATION, UNFOLD PAGE TO LEFT.

The following abbreviations are used to represent values for Control Module Pin-Out data

I	Input	PG	Power Ground	C	CAN Network	D	Serial and Encoded Data
O	Output	SS	Sensor / Signal Supply V	S	SCP Network	V	Voltage (DC)
B+	Battery Voltage	SG	Sensor / Signal Ground	D2	D2B Network	PWM	Pulse Width Modulated

CAUTION: The information on this data page is furnished to aid the user in understanding circuit operation. THIS INFORMATION SHOULD BE USED FOR REFERENCE ONLY.

NOTE: The values listed are approximately those that can be expected at the control module connector pins with all circuit connections made and all components connected and fitted.

Refer to the front of this book for detailed information and illustrations regarding the location and identification of harnesses, relays, fuses, grounds, control modules and control module pins.

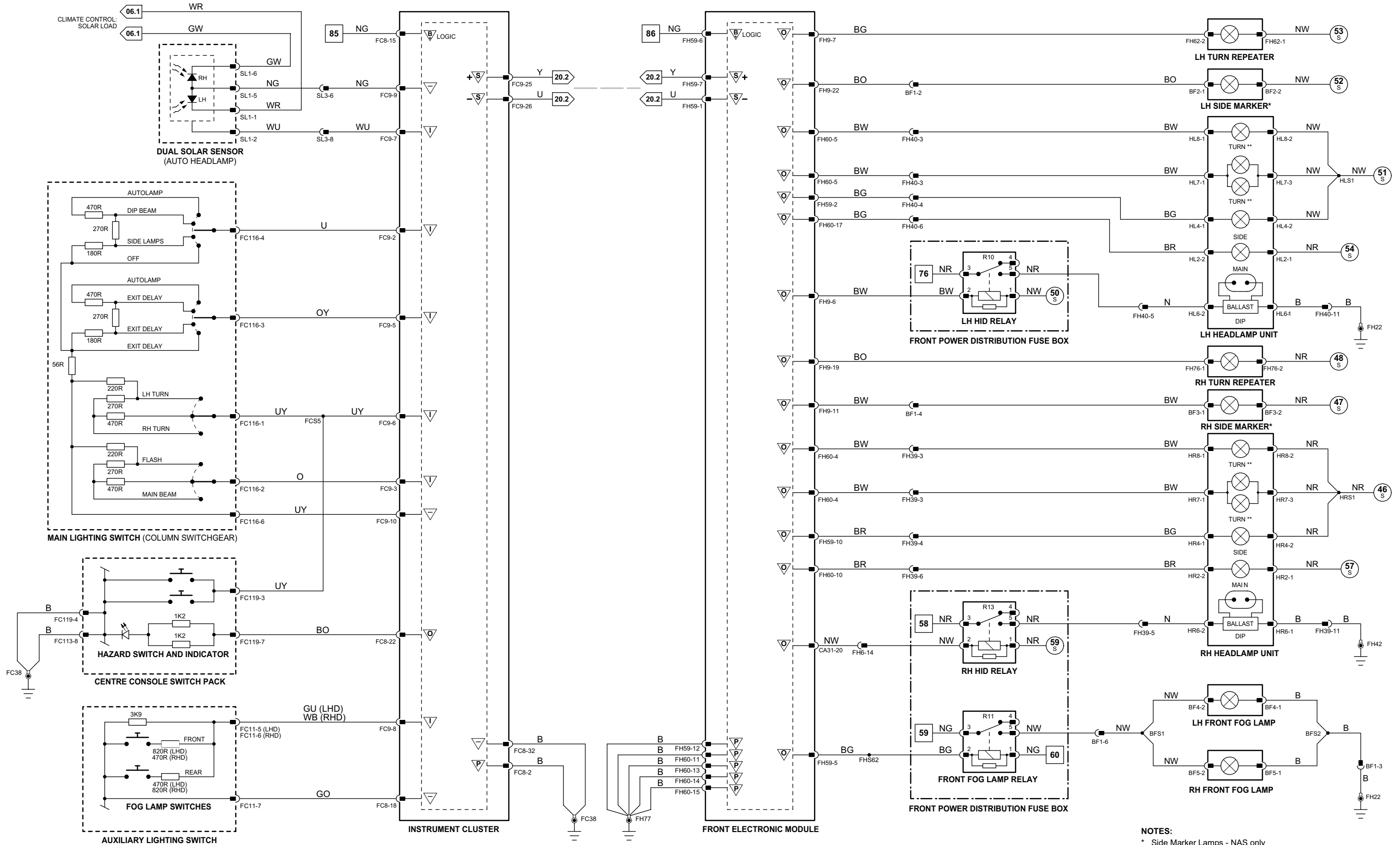

NOTES:
 * Side Marker Lamps - NAS only
 ** Either single or dual filament turn signals fitted.

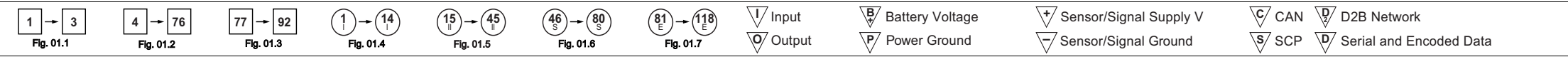

VARIANT: HID Headlamp Vehicles
VIN RANGE: All
DATE OF ISSUE: April 2006

Instrument Cluster

	Pin	Description and Characteristic
PG	FC8-2	POWER GROUND: GROUND
I	FC8-7	REVERSE SWITCH SIGNAL: REVERSE = GROUND
B+	FC8-15	BATTERY POWER SUPPLY (LOGIC): B+
SG	FC8-18	AUXILIARY LIGHTING SWITCH SIGNAL GROUND: GROUND
O	FC8-22	HAZARD INDICATOR: PULSED B+
SG	FC8-32	SIGNAL GROUND: GROUND
I	FC9-2	MAIN LIGHTING SWITCH SIGNALS – OFF, SIDE, DIP, AUTOLAMP: VARIABLE RESISTANCE
I	FC9-3	MAIN LIGHTING SWITCH SIGNALS – MAIN, FLASH: VARIABLE RESISTANCE
I	FC9-5	MAIN LIGHTING SWITCH SIGNALS – EXIT DELAY: VARIABLE RESISTANCE
I	FC9-6	MAIN LIGHTING SWITCH SIGNALS – TURN SIGNALS, HAZARD WARNING: TURN = VARIABLE RESISTANCE; HAZARD = GROUND
I	FC9-8	FOG LAMPS SWITCH SIGNAL: VARIABLE RESISTANCE
SG	FC9-10	MAIN LIGHTING SWITCH SIGNAL GROUND: GROUND
S	FC9-25	SCP +
S	FC9-26	SCP –

Rear Electronic Module

	Pin	Description and Characteristic
O	CA63-1	RH STOP LAMP ACTIVATE: TO ACTIVATE, REM SWITCHES CIRCUIT TO GROUND
O	CA63-2	LH STOP LAMP ACTIVATE: TO ACTIVATE, REM SWITCHES CIRCUIT TO GROUND
O	CA63-3	LH REAR TURN SIGNAL ACTIVATE: TO ACTIVATE, REM SWITCHES CIRCUIT TO GROUND (PULSED)
O	CA63-4	RH REAR TURN SIGNAL ACTIVATE: TO ACTIVATE, REM SWITCHES CIRCUIT TO GROUND (PULSED)
O	CA63-5	RH TAIL LAMPS ACTIVATE: TO ACTIVATE, REM SWITCHES CIRCUIT TO GROUND
O	CA63-6	LH TAIL LAMPS ACTIVATE: TO ACTIVATE, REM SWITCHES CIRCUIT TO GROUND
O	CA63-7	LH REAR FOG LAMP ACTIVATE: TO ACTIVATE, REM SWITCHES CIRCUIT TO GROUND
O	CA63-8	RH REAR FOG LAMP ACTIVATE: TO ACTIVATE, REM SWITCHES CIRCUIT TO GROUND
O	CA63-9	LH REVERSE LAMP ACTIVATE: TO ACTIVATE, REM SWITCHES CIRCUIT TO GROUND
O	CA63-10	RH REVERSE LAMP ACTIVATE: TO ACTIVATE, REM SWITCHES CIRCUIT TO GROUND
O	CA63-17	HIGH-MOUNTED STOP LAMP ACTIVATE: TO ACTIVATE, REM SWITCHES CIRCUIT TO GROUND
O	CA100-5	LICENSE PLATE LAMPS ACTIVATE: TO ACTIVATE, REM SWITCHES CIRCUIT TO GROUND
O	CA100-6	LH REAR SIDE MARKER LAMP ACTIVATE: TO ACTIVATE, REM SWITCHES CIRCUIT TO GROUND
O	CA100-12	RH REAR SIDE MARKER LAMP ACTIVATE: TO ACTIVATE, REM SWITCHES CIRCUIT TO GROUND
B+	CA101-3	BATTERY POWER SUPPLY: B+
S	CA102-1	SCP +
S	CA102-2	SCP –
PG	CA102-12	POWER GROUND: GROUND
I	CA102-13	BRAKE ON / OFF SWITCH (NORMALLY OPEN): OPEN CIRCUIT / B+
PG	CA103-11	POWER GROUND: GROUND
PG	CA103-12	POWER GROUND: GROUND
PG	CA103-25	POWER GROUND: GROUND
PG	CA103-26	POWER GROUND: GROUND

The following abbreviations are used to represent values for Control Module Pin-Out data

I	Input	PG	Power Ground	C	CAN Network	D	Serial and Encoded Data
O	Output	SS	Sensor / Signal Supply V	S	SCP Network	V	Voltage (DC)
B+	Battery Voltage	SG	Sensor / Signal Ground	D2	D2B Network	PWM	Pulse Width Modulated

CAUTION: The information on this data page is furnished to aid the user in understanding circuit operation. THIS INFORMATION SHOULD BE USED FOR REFERENCE ONLY.

NOTE: The values listed are approximately those that can be expected at the control module connector pins with all circuit connections made and all components connected and fitted.

Fig. 08.3

COMPONENTS

Component	Connector(s)	Connector Description	Location
AUXILIARY LIGHTING SWITCH	FC11	10-WAY / YELLOW	FASCIA, ADJACENT TO STEERING COLUMN
BRAKE ON / OFF SWITCH	CA37	2-WAY / GREEN	TOP OF BRAKE PEDAL
CENTER CONSOLE SWITCH PACK	FC113	8-WAY / BLACK	CENTER CONSOLE
	FC119	8-WAY / BLACK	
HIGH-MOUNTED STOP LAMP	CA18	3-WAY / GREY	PARCEL SHELF, CENTER
INSTRUMENT CLUSTER	FC8	32-WAY / BLACK	INSTRUMENT PANEL
	FC9	32-WAY / BLACK	
LICENSE PLATE LAMPS	CA66	4-WAY / BLACK	LUGGAGE COMPARTMENT LID
	CA67	2-WAY / BLACK	
MAIN LIGHTING SWITCH (COLUMN SWITCHGEAR)	FC116	6-WAY / BLACK	STEERING COLUMN COWLING
REAR ELECTRONIC MODULE	CA63	17-WAY / BLACK	LUGGAGE COMPARTMENT, RH REAR
	CA100	12-WAY / BLACK	
	CA101	20-WAY / BLACK	
	CA102	22-WAY / BLACK	
	CA103	26-WAY / NATURAL	
REVERSE SWITCH	GB5	2-WAY / BLACK	TRANSMISSION, LH REAR
SIDE MARKER LAMP – LH	BR6	2-WAY / BLACK	REAR BUMPER, LH SIDE
SIDE MARKER LAMP – RH	BR7	2-WAY / BLACK	REAR BUMPER, RH SIDE
TAIL LAMP UNIT – LH	CA10	7-WAY / BLACK	LUGGAGE COMPARTMENT, LH REAR
TAIL LAMP UNIT – RH	CA68	7-WAY / BLACK	LUGGAGE COMPARTMENT, RH REAR

HARNESS IN-LINE CONNECTORS

Connector	Connector Description / Location	Location
BR1	10-WAY / GREY / CABIN HARNESS TO REAR BUMPER HARNESS	BEHIND REAR BUMPER, RH SIDE
FC12	14-WAY / GREY / FASCIA HARNESS TO FRONT HARNESS	BEHIND INSTRUMENT PANEL, PASSENGER SIDE
GB1	16-WAY / GREY / ENGINE HARNESS TO TRANSMISSION HARNESS	ADJACENT TO TRANSMISSION BELL HOUSING
PI41	42-WAY / BLACK / ENGINE HARNESS TO VEHICLE HARNESSES	ENGINE COMPARTMENT, BULKHEAD, PASSENGER SIDE

GROUNDS

Ground	Location
CA116	BEHIND REAR SEAT BACK, RH SIDE
CA156	LUGGAGE COMPARTMENT, RH SIDE
FC38	UNDER CENTER OF INSTRUMENT PANEL, ON TRANSMISSION TUNNEL
FH4 (LHD)	ENGINE COMPARTMENT, REARWARD OF RH WHEEL ARCH
FH4 (RHD)	ENGINE COMPARTMENT, REARWARD OF LH WHEEL ARCH
PI40 (LHD)	ENGINE COMPARTMENT, BEHIND RH WHEEL ARCH LINER
PI40 (RHD)	ENGINE COMPARTMENT, BEHIND LH WHEEL ARCH LINER

FOR CONTROL MODULE PIN-OUT INFORMATION, UNFOLD PAGE TO LEFT.

Refer to the front of this book for detailed information and illustrations regarding the location and identification of harnesses, relays, fuses, grounds, control modules and control module pins.

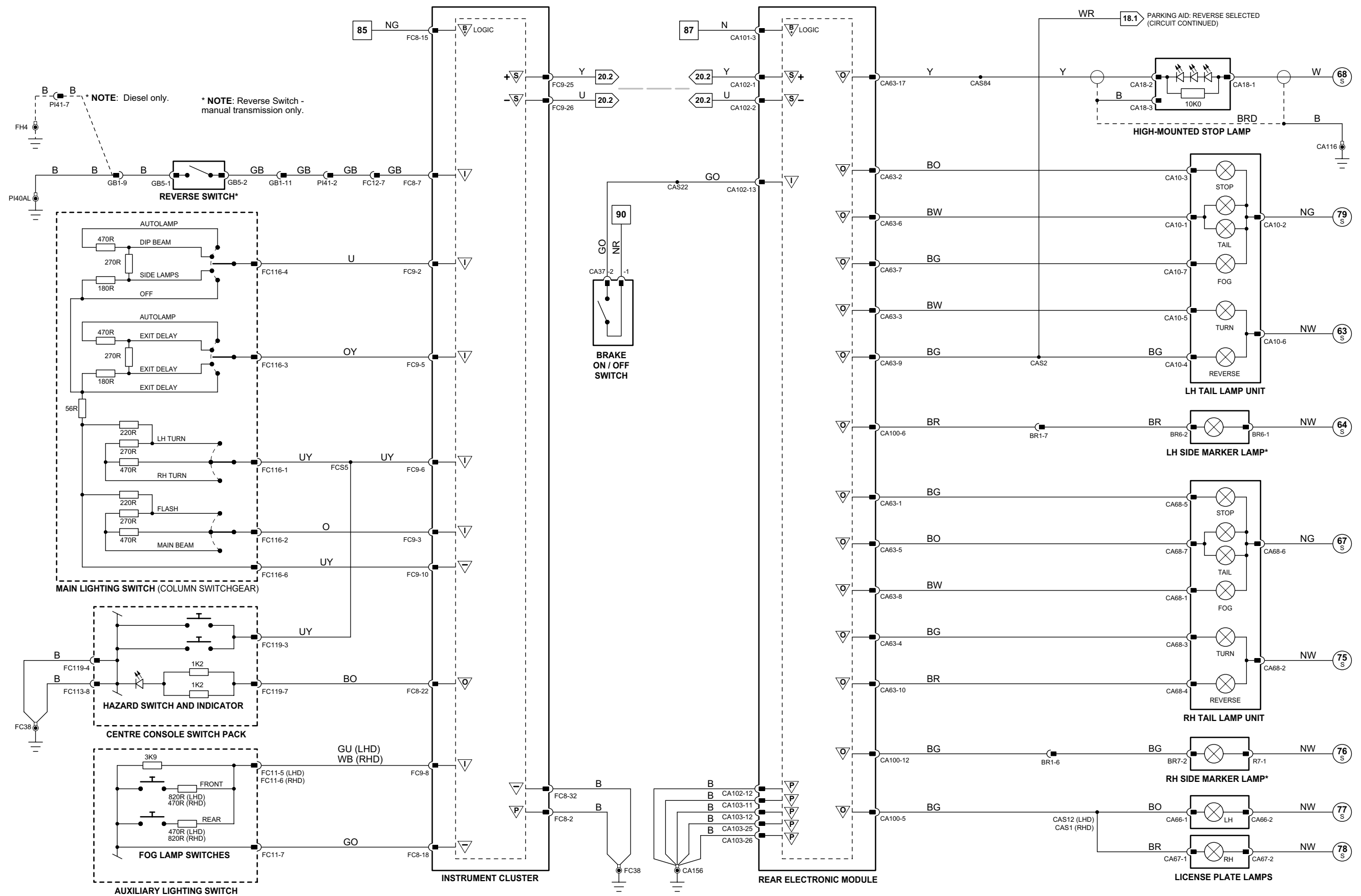

Rear Electronic Module

	Pin	Description and Characteristic
O	CA63-1	RH STOP LAMP ACTIVATE: TO ACTIVATE, REM SWITCHES CIRCUIT TO GROUND
O	CA63-2	LH STOP LAMP ACTIVATE: TO ACTIVATE, REM SWITCHES CIRCUIT TO GROUND
O	CA63-3	LH REAR TURN SIGNAL ACTIVATE: TO ACTIVATE, REM SWITCHES CIRCUIT TO GROUND (PULSED)
O	CA63-4	RH REAR TURN SIGNAL ACTIVATE: TO ACTIVATE, REM SWITCHES CIRCUIT TO GROUND (PULSED)
O	CA63-5	RH TAIL LAMPS ACTIVATE: TO ACTIVATE, REM SWITCHES CIRCUIT TO GROUND
O	CA63-6	LH TAIL LAMPS ACTIVATE: TO ACTIVATE, REM SWITCHES CIRCUIT TO GROUND
O	CA63-7	LH REAR FOG LAMP ACTIVATE: TO ACTIVATE, REM SWITCHES CIRCUIT TO GROUND
O	CA63-8	NOT CONNECTED
O	CA63-9	LH REVERSE LAMP ACTIVATE: TO ACTIVATE, REM SWITCHES CIRCUIT TO GROUND
O	CA63-10	RH REVERSE LAMP ACTIVATE: TO ACTIVATE, REM SWITCHES CIRCUIT TO GROUND
O	CA63-17	HIGH-MOUNTED STOP LAMP ACTIVATE: TO ACTIVATE, REM SWITCHES CIRCUIT TO GROUND
O	CA100-5	LICENSE PLATE LAMPS ACTIVATE: TO ACTIVATE, REM SWITCHES CIRCUIT TO GROUND
O	CA100-6	LH REAR SIDE MARKER LAMP ACTIVATE: TO ACTIVATE, REM SWITCHES CIRCUIT TO GROUND
O	CA100-12	RH REAR SIDE MARKER LAMP ACTIVATE: TO ACTIVATE, REM SWITCHES CIRCUIT TO GROUND
B+	CA101-3	BATTERY POWER SUPPLY: B+
PG	CA102-12	POWER GROUND: GROUND
I	CA102-13	BRAKE ON / OFF SWITCH (NORMALLY OPEN): OPEN CIRCUIT / B+
PG	CA103-11	POWER GROUND: GROUND
PG	CA103-12	POWER GROUND: GROUND
PG	CA103-25	POWER GROUND: GROUND
PG	CA103-26	POWER GROUND: GROUND

Fig. 08.4

COMPONENTS

Component	Connector(s)	Connector Description	Location
BATTERY	—	—	LUGGAGE COMPARTMENT
BRAKE ON / OFF SWITCH	CA37	2-WAY / GREEN	TOP OF BRAKE PEDAL
HIGH-MOUNTED STOP LAMP	CA18	3-WAY / GREY	PARCEL SHELF, CENTER
LICENSE PLATE LAMPS	CA66	4-WAY / BLACK	LUGGAGE COMPARTMENT LID
	CA67	2-WAY / BLACK	
REAR ELECTRONIC MODULE	CA63	17-WAY / BLACK	LUGGAGE COMPARTMENT, RH REAR
	CA100	12-WAY / BLACK	
	CA101	20-WAY / BLACK	
	CA102	22-WAY / BLACK	
	CA103	26-WAY / NATURAL	
SIDE MARKER LAMP – LH	BR6	2-WAY / BLACK	REAR BUMPER, LH SIDE
SIDE MARKER LAMP – RH	BR7	2-WAY / BLACK	REAR BUMPER, RH SIDE
TAIL LAMP UNIT – LH	TT6	NOT AVAILABLE	LUGGAGE COMPARTMENT, LH REAR
TAIL LAMP UNIT – RH	TT2	NOT AVAILABLE	LUGGAGE COMPARTMENT, RH REAR
TRAILER TOWING CONNECTOR (12N)	TT7	NOT AVAILABLE	LUGGAGE COMPARTMENT
TRAILER TOWING CONNECTOR (12S)	TT8	NOT AVAILABLE	LUGGAGE COMPARTMENT
TRAILER TOWING CONTROL MODULE	TT15	NOT AVAILABLE	LUGGAGE COMPARTMENT
	TT16		
	TT17		
TRAILER TOWING JUNCTION BOX	TT12	NOT AVAILABLE	LUGGAGE COMPARTMENT
TRAILER TOWING RELAY	TT9	RELAY CONNECTOR	LUGGAGE COMPARTMENT

HARNESS IN-LINE CONNECTORS

Connector	Connector Description / Location	Location
BR1	10-WAY / GREY / CABIN HARNESS TO REAR BUMPER HARNESS	BEHIND REAR BUMPER, RH SIDE
CA305	NOT AVAILABLE	LUGGAGE COMPARTMENT, ADJACENT TO RH TAIL LAMP
CA306	NOT AVAILABLE	LUGGAGE COMPARTMENT, ADJACENT TO RH TAIL LAMP
TT1	NOT AVAILABLE	LUGGAGE COMPARTMENT, ADJACENT TO RH TAIL LAMP
TT3	NOT AVAILABLE	LUGGAGE COMPARTMENT, ADJACENT TO RH TAIL LAMP
TT5	NOT AVAILABLE	LUGGAGE COMPARTMENT, ADJACENT TO RH TAIL LAMP

GROUNDS

Ground	Location
CA116	BEHIND REAR SEAT BACK, RH SIDE
CA156	LUGGAGE COMPARTMENT, RH SIDE
JB1	LUGGAGE COMPARTMENT, BATTERY GROUND
TT4	NOT AVAILABLE

FOR CONTROL MODULE PIN-OUT INFORMATION, UNFOLD PAGE TO LEFT.

The following abbreviations are used to represent values for Control Module Pin-Out data

I	Input	PG	Power Ground	C	CAN Network	D	Serial and Encoded Data
O	Output	SS	Sensor / Signal Supply V	S	SCP Network	V	Voltage (DC)
B+	Battery Voltage	SG	Sensor / Signal Ground	D2	D2B Network	PWM	Pulse Width Modulated

CAUTION: The information on this data page is furnished to aid the user in understanding circuit operation. THIS INFORMATION SHOULD BE USED FOR REFERENCE ONLY.

NOTE: The values listed are approximately those that can be expected at the control module connector pins with all circuit connections made and all components connected and fitted.

Refer to the front of this book for detailed information and illustrations regarding the location and identification of harnesses, relays, fuses, grounds, control modules and control module pins.

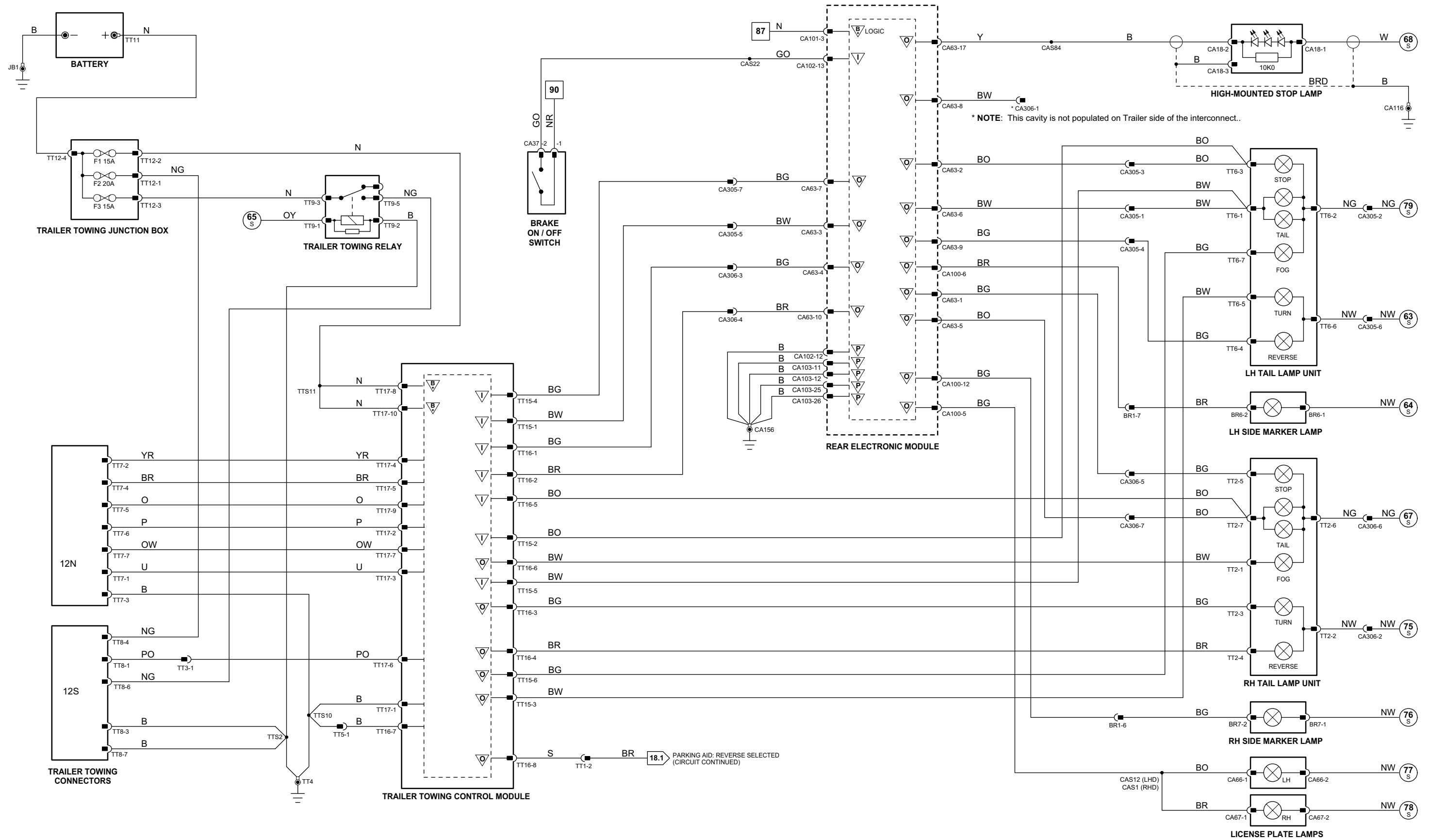

1 → 3
Fig. 01.1

4 → 76
Fig. 01.2

77 → 92
Fig. 01.3

1 → 14
Fig. 01.4

15 → 45
Fig. 01.5

46 → 80
Fig. 01.8

81 → 118
Fig. 01.7

Input
Output

B Battery Voltage
P Power Ground

∇ Sensor/Signal Supply V
∇ Sensor/Signal Ground

∇ CAN ∇ D2B Network
∇ SCP ∇ Serial and Encoded Data

VARIANT: Trailer Towing Vehicles
VIN RANGE: All
DATE OF ISSUE: April 2006

Fig. 08.5**COMPONENTS**

Component	Connector(s)	Connector Description	Location
AUXILIARY LIGHTING SWITCH	FC11	10-WAY / YELLOW	FASCIA, ADJACENT TO STEERING COLUMN
HEADLAMP LEVELING ACTUATOR – LH	HL1	3-WAY / BLACK	BEHIND LH HEADLAMP UNIT
HEADLAMP LEVELING ACTUATOR – RH	HR1	3-WAY / BLACK	BEHIND RH HEADLAMP UNIT
HEADLAMP LEVELING CONTROL MODULE	FH12	26-WAY / BLACK	RH 'A' POST, ABOVE PRIMARY JUNCTION FUSE BOX
HID HEADLAMP UNIT – LH	HL10	4-WAY / BLACK	ENGINE COMPARTMENT, LH FRONT
HID HEADLAMP UNIT – RH	HR10	4-WAY / BLACK	ENGINE COMPARTMENT, RH FRONT
RIDE HEIGHT SENSOR – FRONT AXLE	FH113	6-WAY / BLACK	RH FRONT SUSPENSION
RIDE HEIGHT SENSOR – REAR AXLE	CA240	6-WAY / BLACK	RH REAR SUSPENSION

HARNESS IN-LINE CONNECTORS

Connector	Connector Description / Location	Location
FC4	14-WAY / GREEN / FASCIA HARNESS IN-LINE CONNECTOR	BEHIND INSTRUMENT PANEL, LH SIDE
FH2	16-WAY / GREY / CABIN HARNESS TO FRONT HARNESS	RH 'A' POST, LOWER
FH39	12-WAY / GREY / FRONT HARNESS TO RH FRONT HEADLAMP LINK	BEHIND FRONT BUMPER, RH SIDE
FH40	12-WAY / GREY / FRONT HARNESS TO LH FRONT HEADLAMP LINK	BEHIND FRONT BUMPER, LH SIDE

GROUNDS

Ground	Location
FC38	UNDER CENTER OF INSTRUMENT PANEL, ON TRANSMISSION TUNNEL
FH22	ENGINE COMPARTMENT, BEHIND LH HEADLAMP
FH42	ENGINE COMPARTMENT, BEHIND RH HEADLAMP

Refer to the front of this book for detailed information and illustrations regarding the location and identification of harnesses, relays, fuses, grounds, control modules and control module pins.

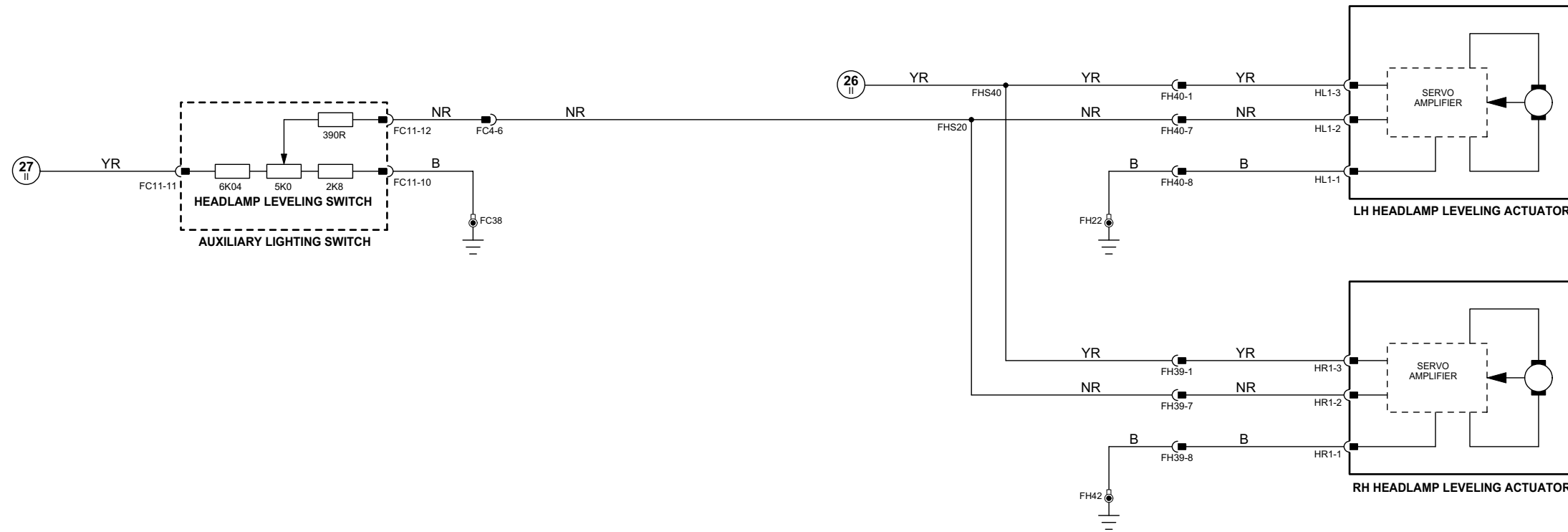

DRIVER-CONTROLLED HEADLAMP LEVELING

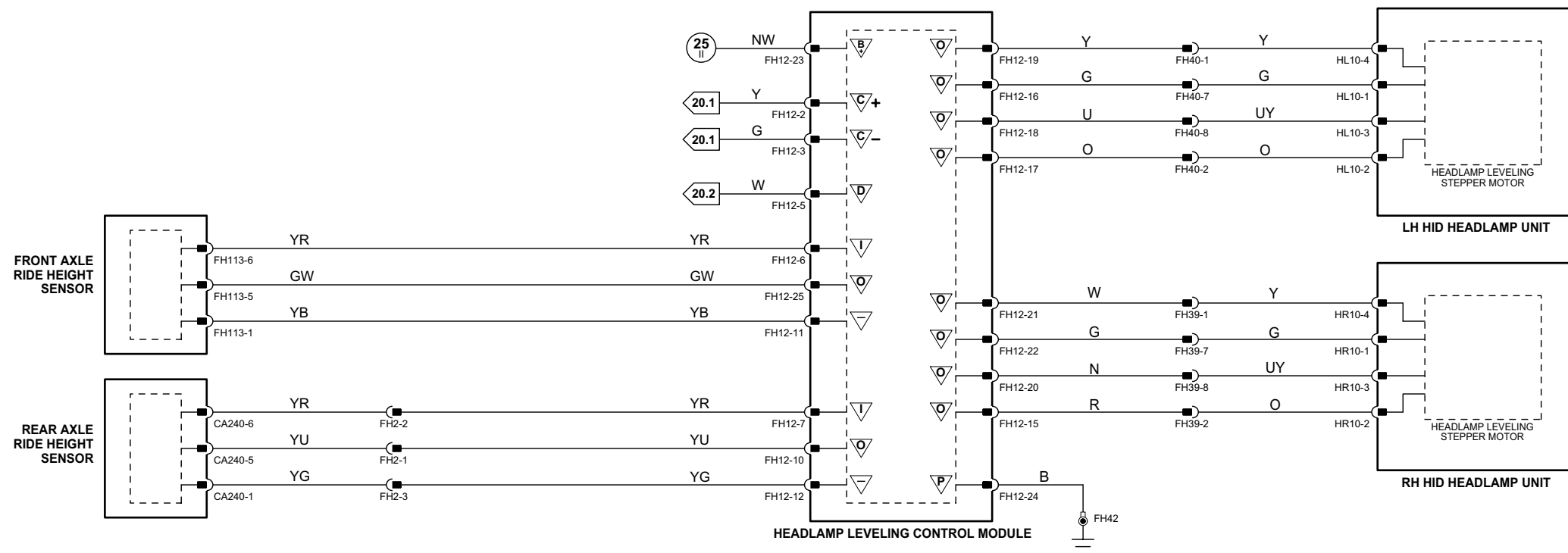

AUTOMATIC HEADLAMP LEVELING (HID HEADLAMPS)

Driver Door Module

	Pin	Description and Characteristic
S	CA85-3	SCP +
S	CA85-4	SCP -
PG	CA85-8	POWER GROUND: GROUND
B+	CA85-11	BATTERY POWER SUPPLY: B+
I	DT2-16	DRIVER DOOR ALARM SET / LOCK SWITCH (NORMALLY OPEN): OPEN CIRCUIT / GROUND
I	DT2-17	DRIVER DOOR ALARM RESET / UNLOCK SWITCH (NORMALLY OPEN): OPEN CIRCUIT / GROUND

Front Electronic Module

	Pin	Description and Characteristic
I	CA24-15	PASSENGER DOOR AJAR SWITCH (NORMALLY OPEN): OPEN CIRCUIT / GROUND
I	CA31-8	DRIVER DOOR AJAR SWITCH (NORMALLY OPEN): OPEN CIRCUIT / GROUND
—	CA31-12	INTERIOR LIGHTING ACTIVATE: TO ACTIVATE, FEM SWITCHES CIRCUIT TO GROUND (PWM)
S	FH59-1	SCP -
B+	FH59-6	BATTERY POWER SUPPLY (LOGIC): B+
S	FH59-7	SCP +
PG	FH60-11	POWER GROUND: GROUND

Instrument Cluster

	Pin	Description and Characteristic
PG	FC8-2	POWER GROUND: GROUND
SG	FC8-8	ROOF CONSOLE COURTESY LAMP SWITCH GROUND: SWITCH OPEN = GROUND
B+	FC8-15	BATTERY POWER SUPPLY (LOGIC): B+
SG	FC8-32	SIGNAL GROUND: GROUND
S	FC9-25	SCP +
S	FC9-26	SCP -

Rear Electronic Module

	Pin	Description and Characteristic
O	CA100-11	TRUNK LAMPS ACTIVATE: TO ACTIVATE, REM SWITCHES CIRCUIT TO GROUND
B+	CA101-3	BATTERY POWER SUPPLY: B+
I	CA101-17	LHD - RH REAR DOOR AJAR SWITCH (NORMALLY OPEN): OPEN CIRCUIT / GROUND RHD - LH REAR DOOR AJAR SWITCH (NORMALLY OPEN): OPEN CIRCUIT / GROUND
S	CA102-1	SCP +
S	CA102-2	SCP -
PG	CA102-12	POWER GROUND: GROUND
I	CA102-14	TRUNK AJAR SWITCH (NORMALLY OPEN): OPEN CIRCUIT / GROUND
I	CA103-16	LHD - LH REAR DOOR AJAR SWITCH (NORMALLY OPEN): OPEN CIRCUIT / GROUND RHD - RH REAR DOOR AJAR SWITCH (NORMALLY OPEN): OPEN CIRCUIT / GROUND

The following abbreviations are used to represent values for Control Module Pin-Out data

I	Input	PG	Power Ground	C	CAN Network	D	Serial and Encoded Data
O	Output	SS	Sensor / Signal Supply V	S	SCP Network	V	Voltage (DC)
B+	Battery Voltage	SG	Sensor / Signal Ground	D2	D2B Network	PWM	Pulse Width Modulated

CAUTION: The information on this data page is furnished to aid the user in understanding circuit operation. THIS INFORMATION SHOULD BE USED FOR REFERENCE ONLY.

NOTE: The values listed are approximately those that can be expected at the control module connector pins with all circuit connections made and all components connected and fitted.

Fig. 09.1

COMPONENTS

Component	Connector(s)	Connector Description	Location
COURTESY LAMP - DRIVER DOOR	DD6	2-WAY / BLACK	DRIVER DOOR CASING
COURTESY LAMP - PASSENGER DOOR	PD3	2-WAY / BLACK	PASSENGER DOOR CASING
DOOR LATCH ASSEMBLY - DRIVER	DT5	10-WAY / BLACK	DRIVER DOOR
DOOR LATCH ASSEMBLY - PASSENGER	PT3	10-WAY / BLACK	PASSENGER DOOR
DOOR LATCH ASSEMBLY - LH REAR	CA81	10-WAY / BLACK	LH REAR DOOR
DOOR LATCH ASSEMBLY - RH REAR	CA90	10-WAY / BLACK	RH REAR DOOR
DRIVER DOOR MODULE	CA85	12-WAY / BLACK	DRIVER DOOR
	DD4	26-WAY / NATURAL	
	DT2	20-WAY / BLACK	
FASCIA LAMP - LH	FC44	2-WAY / WHITE	INSTRUMENT PANEL, LH SIDE
FASCIA LAMP - RH	FC51	2-WAY / WHITE	INSTRUMENT PANEL, RH SIDE
FRONT ELECTRONIC MODULE	CA24	26-WAY / NATURAL	LH 'A' POST
	CA31	20-WAY / BLACK	
	FH9	22-WAY / BLACK	
	FH59	12-WAY / BLACK	
	FH60	17-WAY / BLACK	
GLOVE BOX LAMP	GL1	2-WAY / BLACK	GLOVE BOX
INSTRUMENT CLUSTER	FC8	32-WAY / BLACK	INSTRUMENT PANEL
	FC9	32-WAY / BLACK	
MAP LAMP - LH REAR	RF20	3-WAY / BLACK	LH REAR ASSIST HANDLE
MAP LAMP - RH REAR	RF23	3-WAY / BLACK	RH REAR ASSIST HANDLE
REAR ELECTRONIC MODULE	CA63	17-WAY / BLACK	LUGGAGE COMPARTMENT, RH REAR
	CA100	12-WAY / BLACK	
	CA101	20-WAY / BLACK	
	CA102	22-WAY / BLACK	
	CA103	26-WAY / NATURAL	
ROOF CONSOLE	CA250	22-WAY / BLACK	ROOF HEADLINER
SUN VISOR LAMP - LH	RF12	2-WAY / BLACK	LH SUN VISOR
SUN VISOR LAMP - RH	RF24	2-WAY / BLACK	RH SUN VISOR
TRUNK AJAR SWITCH	CA26	2-WAY / BLACK	LUGGAGE COMPARTMENT LID
TRUNK LAMP - LH	CA96	2-WAY / BLACK	LUGGAGE COMPARTMENT, LH SIDE
TRUNK LID LAMP	CA167	2-WAY / BLACK	LUGGAGE COMPARTMENT LID

HARNESS IN-LINE CONNECTORS

Connector	Connector Description / Location	Location
DD8	16-WAY / BLUE / CABIN HARNESS TO DRIVER DOOR HARNESS	DRIVER DOOR
DT8	14-WAY / GREY / CABIN HARNESS TO DRIVER DOOR TRIM HARNESS	DRIVER DOOR
FC23	10-WAY / GREY / CABIN HARNESS TO FASCIA HARNESS	BEHIND INSTRUMENT PANEL, LH SIDE
FC33	16-WAY / GREEN / CABIN HARNESS TO FASCIA HARNESS	BEHIND INSTRUMENT PANEL, RH SIDE
PD4	10-WAY / GREY / CABIN HARNESS TO PASSENGER DOOR HARNESS	PASSENGER DOOR
PT1	14-WAY / GREY / CABIN HARNESS TO PASSENGER DOOR TRIM HARNESS	PASSENGER DOOR
RF34	16-WAY / GREEN / CABIN HARNESS TO DOOR HARNESS	'D' POST, UNDER PARCEL SHELF

GROUNDS

Ground	Location
CA30	LH LOWER 'A' POST, ADJACENT TO THE FRONT ELECTRONIC MODULE (REARWARD OF FH77)
CA50	RH LOWER 'A' POST, BELOW PRIMARY JUNCTION FUSE BOX
CA116	BEHIND REAR SEAT BACK, RH SIDE
CA141	UNDER LH FRONT SEAT
CA154	UNDER RH FRONT SEAT
CA156	LUGGAGE COMPARTMENT, RH SIDE
FC38	UNDER CENTER OF INSTRUMENT PANEL, ON TRANSMISSION TUNNEL
FH77	LH LOWER 'A' POST, ADJACENT TO THE FRONT ELECTRONIC MODULE (FORWARD OF CA30)

FOR CONTROL MODULE PIN-OUT INFORMATION, UNFOLD PAGE TO LEFT.

Refer to the front of this book for detailed information and illustrations regarding the location and identification of harnesses, relays, fuses, grounds, control modules and control module pins.

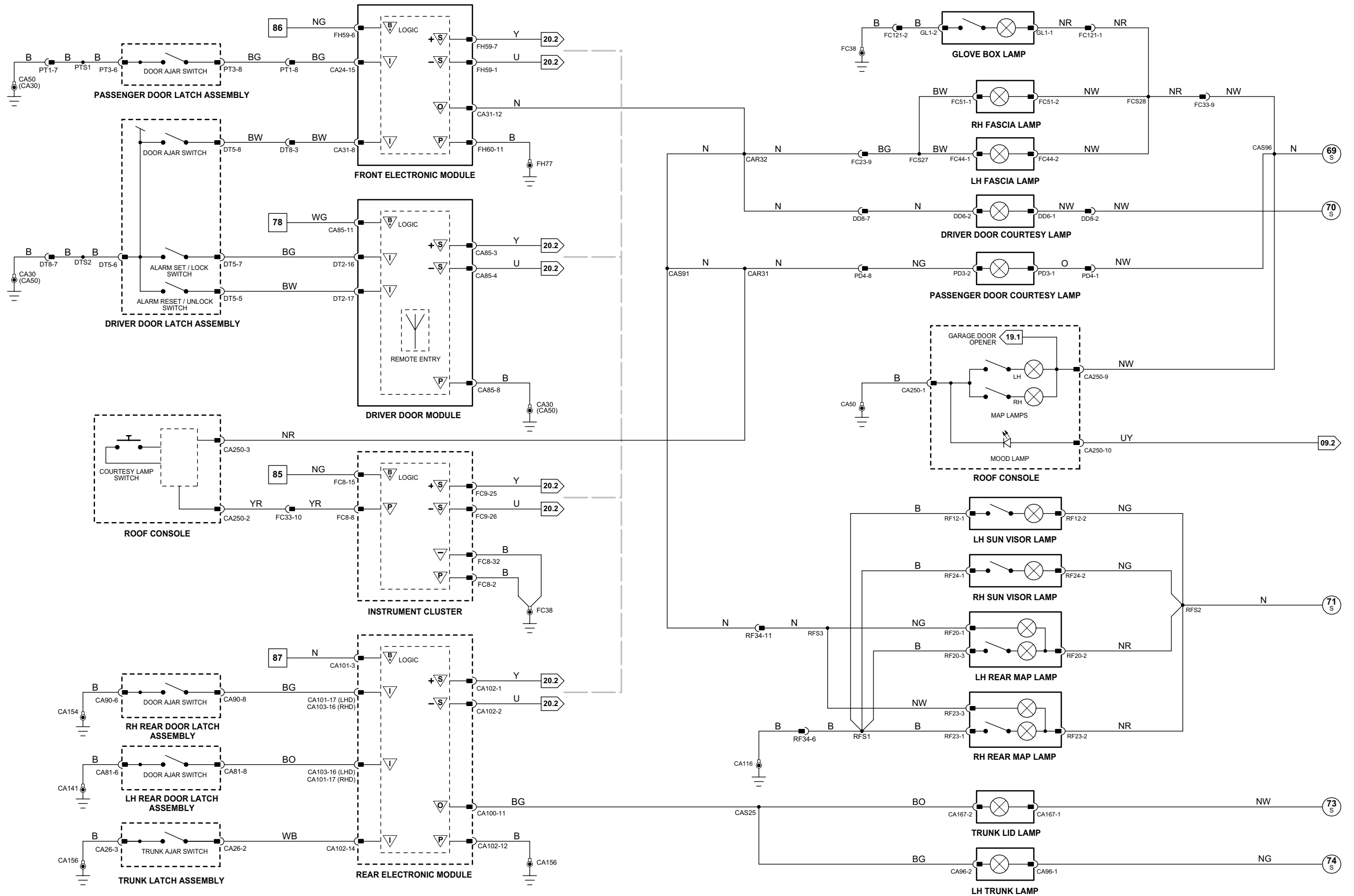

1 → 3
Fig. 01.1

4 → 76
Fig. 01.2

77 → 92
Fig. 01.3

1 → 14
Fig. 01.4

15 → 45
Fig. 01.5

46 → 80
Fig. 01.6

81 → 118
Fig. 01.7

▽ Input
 ▽ Output
 B Battery Voltage
 P Power Ground
 +S Sensor/Signal Supply V
 -S Sensor/Signal Ground
 C CAN
 S SCP
 D2B Network
 D Serial and Encoded Data

VARIANT: All Vehicles
 VIN RANGE: All
 DATE OF ISSUE: April 2006

Air Conditioning Control Module – Panel

Pin	Description and Characteristic
I FC41-15	PANEL ILLUMINATION (DIMMER-CONTROLLED): B+ (PWM)

Audio Unit

Pin	Description and Characteristic
I FC94-17	DIMMER-CONTROLLED ILLUMINATION: PWM, 80 Hz, GROUND = 0% DUTY CYCLE, B+ = 100% DUTY CYCLE

Front Electronic Module

Pin	Description and Characteristic
B+ CA31-1	SWITCHED SYSTEM POWER SUPPLY: B+
O CA31-11	BACKLIGHTING ACTIVATE: B+ (PWM)
S FH59-1	SCP –
B+ FH59-6	BATTERY POWER SUPPLY (LOGIC): B+
S FH59-7	SCP +
PG FH59-12	POWER GROUND: GROUND
PG FH60-11	POWER GROUND: GROUND
PG FH60-13	POWER GROUND: GROUND
PG FH60-14	POWER GROUND: GROUND
PG FH60-15	POWER GROUND: GROUND

Instrument Cluster

Pin	Description and Characteristic
PG FC8-2	POWER GROUND: GROUND
SS FC8-11	DIMMER SUPPLY VOLTAGE: B+
B+ FC8-15	BATTERY POWER SUPPLY (LOGIC): B+
SG FC8-18	AUXILIARY LIGHTING SWITCH SIGNAL GROUND: GROUND
SG FC8-32	SIGNAL GROUND: GROUND
I FC9-2	MAIN LIGHTING SWITCH SIGNALS – OFF, SIDE, DIP, AUTOLAMP: VARIABLE RESISTANCE
I FC9-4	DIMMER SIGNAL: VARIABLE VOLTAGE
I FC9-5	MAIN LIGHTING SWITCH SIGNALS – EXIT DELAY: VARIABLE RESISTANCE
SG FC9-10	MAIN LIGHTING SWITCH SIGNAL GROUND: GROUND
S FC9-25	SCP +
S FC9-26	SCP –

Fig. 09.2

COMPONENTS

Component	Connector(s)	Connector Description	Location
AIR CONDITIONING CONTROL MODULE – PANEL	FC40	26-WAY / GREY	CENTER CONSOLE
	FC41	22-WAY / GREY	
AUDIO UNIT	FC94	20-WAY / BLACK	CENTER CONSOLE
	FC96	ANTENNA CONNECTOR	
	FC108	FIBER OPTIC CONNECTOR	
AUXILIARY LIGHTING SWITCH	FC11	10-WAY / YELLOW	FASCIA, ADJACENT TO STEERING COLUMN
CENTER CONSOLE SWITCH PACK	FC113	8-WAY / BLACK	CENTER CONSOLE
	FC119	8-WAY / BLACK	
CIGAR LIGHTER	CA109	3-WAY / BLACK	CENTER CONSOLE
DOOR SWITCH PACK – DRIVER	DD2	26-WAY / YELLOW	DRIVER DOOR ARM REST
FRONT ELECTRONIC MODULE	CA24	26-WAY / NATURAL	LH 'A' POST
	CA31	20-WAY / BLACK	
	FH9	22-WAY / BLACK	
	FH59	12-WAY / BLACK	
	FH60	17-WAY / BLACK	
FUEL FLAP / TRUNK RELEASE SWITCH PACK	FC43	10-WAY / GREY	INSTRUMENT PANEL
INSTRUMENT CLUSTER	FC8	32-WAY / BLACK	INSTRUMENT PANEL
	FC9	32-WAY / BLACK	
J-GATE MODULE	CA245	16-WAY / BLACK	J-GATE ASSEMBLY
MAIN LIGHTING SWITCH (COLUMN SWITCHGEAR)	FC116	6-WAY / BLACK	STEERING COLUMN COWLING
PRIMARY JUNCTION FUSE BOX	CA2	26-WAY / BLACK	RH 'A' POST
	CA56	8-WAY / BLACK	
	FC37	26-WAY / BLACK	
	FH7	6-WAY / BLACK	
	FH53	10-WAY / BLACK	
ROOF CONSOLE	CA250	22-WAY / BLACK	ROOF HEADLINER
STEERING WHEEL LIGHTING	SQ1	4-WAY / BLACK	STEERING WHEEL
	SQ3	4-WAY / BLACK	
TELEMATICS DISPLAY	FC92	22-WAY / BLACK	CENTER CONSOLE
WINDOW SWITCH – LH REAR	CA78	5-WAY / GREEN	LH REAR DOOR ARM REST
WINDOW SWITCH – PASSENGER	PD1	5-WAY / GREEN	PASSENGER DOOR ARM REST
WINDOW SWITCH – RH REAR	CA95	5-WAY / GREEN	RH REAR DOOR ARM REST

HARNESS IN-LINE CONNECTORS

Connector	Connector Description / Location	Location
DD8	16-WAY / BLUE / CABIN HARNESS TO DRIVER DOOR HARNESS	DRIVER DOOR
FC23	10-WAY / GREY / CABIN HARNESS TO FASCIA HARNESS	BEHIND INSTRUMENT PANEL, LH SIDE
FC117	10-WAY / BLACK / STEERING WHEEL CASSETTE	STEERING COLUMN
PD4	10-WAY / GREY / CABIN HARNESS TO PASSENGER DOOR HARNESS	PASSENGER DOOR

GROUNDS

Ground	Location
CA30	LH LOWER 'A' POST, ADJACENT TO THE FRONT ELECTRONIC MODULE (REARWARD OF FH77)
CA50	RH LOWER 'A' POST, BELOW PRIMARY JUNCTION FUSE BOX
CA141	UNDER LH FRONT SEAT
CA154	UNDER RH FRONT SEAT
FC38	UNDER CENTER OF INSTRUMENT PANEL, ON TRANSMISSION TUNNEL
FH77	LH LOWER 'A' POST, ADJACENT TO THE FRONT ELECTRONIC MODULE (FORWARD OF CA30)

FOR CONTROL MODULE PIN-OUT INFORMATION, UNFOLD PAGE TO LEFT.

The following abbreviations are used to represent values for Control Module Pin-Out data

I	Input	PG	Power Ground	C	CAN Network	D	Serial and Encoded Data
O	Output	SS	Sensor / Signal Supply V	S	SCP Network	V	Voltage (DC)
B+	Battery Voltage	SG	Sensor / Signal Ground	D2	D2B Network	PWM	Pulse Width Modulated

CAUTION: The information on this data page is furnished to aid the user in understanding circuit operation. THIS INFORMATION SHOULD BE USED FOR REFERENCE ONLY.

NOTE: The values listed are approximately those that can be expected at the control module connector pins with all circuit connections made and all components connected and fitted.

Refer to the front of this book for detailed information and illustrations regarding the location and identification of harnesses, relays, fuses, grounds, control modules and control module pins.

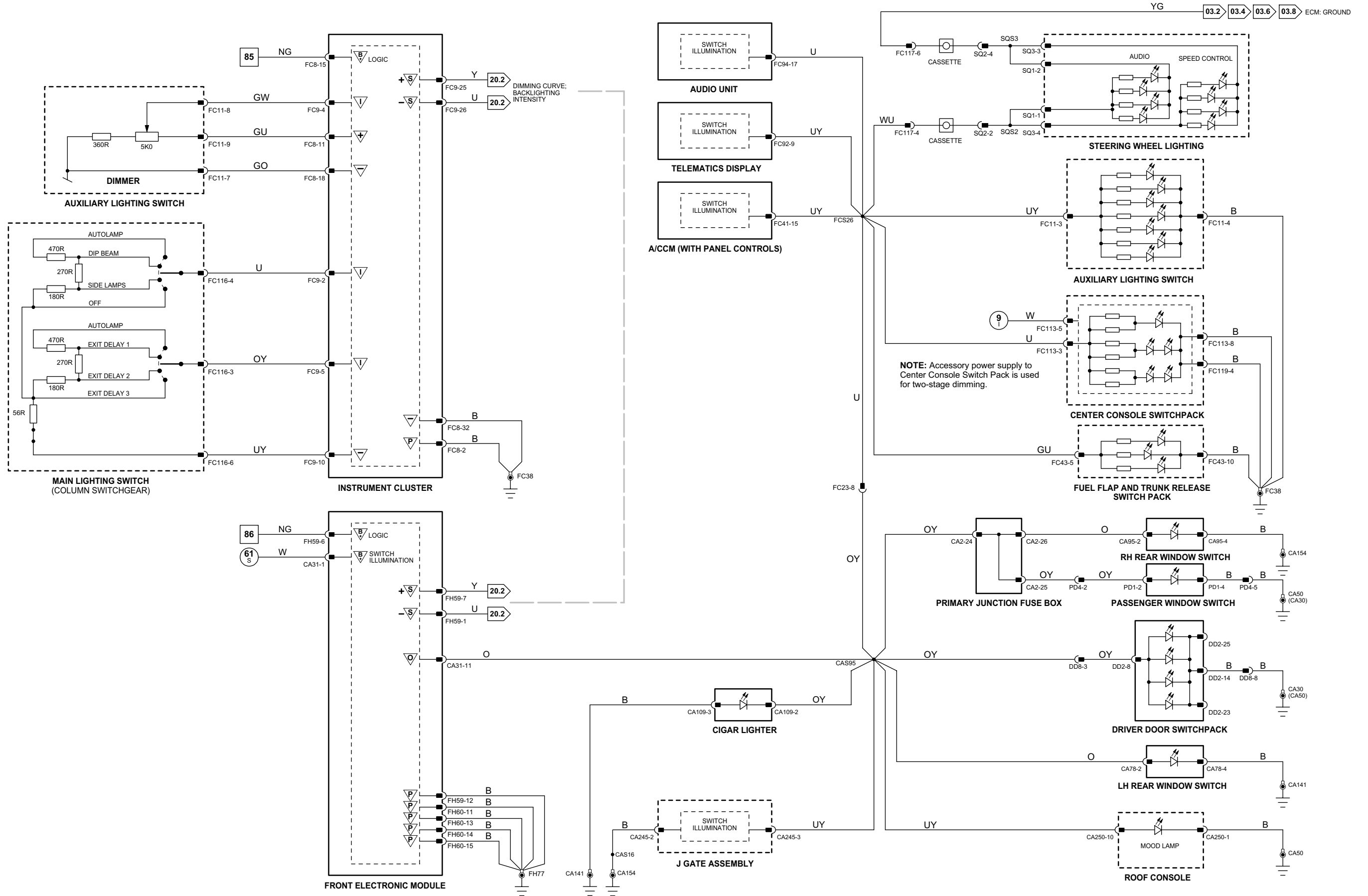

1 → 3
Fig. 01.1

4 → 76
Fig. 01.2

77 → 92
Fig. 01.3

1 → 14
Fig. 01.4

15 → 45
Fig. 01.5

46 → 80
Fig. 01.8

81 → 118
Fig. 01.7

Input
Output

Battery Voltage
Power Ground

Sensor/Signal Supply V
Sensor/Signal Ground

CAN
SCP

D2B Network
Serial and Encoded Data

VARIANT: All Vehicles
VIN RANGE: All
DATE OF ISSUE: April 2006

Fig. 10.1

Driver Door Module

	Pin	Description and Characteristic
S	CA85-3	SCP +
S	CA85-4	SCP -
PG	CA85-8	POWER GROUND: GROUND
B+	CA85-11	BATTERY POWER SUPPLY: B+
O	DD4-7	MEMORY SET INDICATOR: TO ACTIVATE, DDM SWITCHES CIRCUIT TO B+
I	DD4-10	MEMORY 1: GROUND WHEN SELECTED
I	DD4-11	MEMORY 2: GROUND WHEN SELECTED
I	DD4-25	MEMORY SET: GROUND WHEN SELECTED

Front Electronic Module

	Pin	Description and Characteristic
I	CA24-5	PEDAL ADJUST MOTOR POSITION SENSOR SIGNAL: VARIABLE VOLTAGE
O	CA24-12	PEDAL ADJUST MOTOR DRIVE - IN: TO ACTIVATE, FEM SWITCHES CIRCUIT TO B+
SG	CA24-18	PEDAL ADJUST MOTOR POSITION SENSOR SIGNAL GROUND: GROUND
O	CA24-26	PEDAL ADJUST MOTOR DRIVE - OUT: TO ACTIVATE, FEM SWITCHES CIRCUIT TO B+
I	CA31-8	DRIVER DOOR AJAR SWITCH (NORMALLY OPEN): OPEN CIRCUIT / GROUND
SS	CA31-16	PEDAL ADJUST MOTOR POSITION SENSOR SIGNAL SUPPLY VOLTAGE: NOMINAL 5 V
I	FH9-8	PEDALS OUT REQUEST (NORMALLY OPEN): OPEN CIRCUIT / GROUND
I	FH9-17	PEDALS IN REQUEST (NORMALLY OPEN): OPEN CIRCUIT / GROUND
S	FH59-1	SCP -
S	FH59-7	SCP +
B+	FH60-1	SWITCHED SYSTEM POWER SUPPLY: B+
PG	FH60-11	POWER GROUND: GROUND

Instrument Cluster

	Pin	Description and Characteristic
PG	FC8-2	POWER GROUND: GROUND
O	FC8-10	STEERING COLUMN POSITION FEEDBACK POTENTIOMETERS SUPPLY VOLTAGE: B+
B+	FC8-15	BATTERY POWER SUPPLY (LOGIC): B+
O	FC8-25	STEERING COLUMN IN / OUT FUNCTION SOLENOID DRIVE: B+ WHEN ACTIVATED
O	FC8-26	STEERING COLUMN UP / DOWN FUNCTION SOLENOID DRIVE: B+ WHEN ACTIVATED
O	FC8-27	STEERING COLUMN MOTOR DOWN / IN DRIVE: B+ WHEN ACTIVATED
B+	FC8-29	BATTERY POWER SUPPLY (COLUMN MOTOR)
O	FC8-30	STEERING COLUMN MOTOR UP / OUT DRIVE: B+ WHEN ACTIVATED
SG	FC8-32	SIGNAL GROUND: GROUND
SG	FC9-11	STEERING COLUMN POSITION FEEDBACK POTENTIOMETERS SIGNAL GROUND: GROUND
I	FC9-18	STEERING COLUMN MOVEMENT SWITCH SIGNAL: VARIABLE VOLTAGE
I	FC9-20	STEERING COLUMN UP / DOWN POSITION FEEDBACK POTENTIOMETER SIGNAL: VARIABLE VOLTAGE
I	FC9-21	STEERING COLUMN IN / OUT POSITION FEEDBACK POTENTIOMETER SIGNAL: VARIABLE VOLTAGE
I	FC9-22	FUNCTION SELECT SIGNAL: VARIABLE RESISTANCE
SG	FC9-23	STEERING COLUMN MOVEMENT / SELECT SIGNAL GROUND: GROUND
S	FC9-25	SCP +
S	FC9-26	SCP -

The following abbreviations are used to represent values for Control Module Pin-Out data

I	Input	PG	Power Ground	C	CAN Network	D	Serial and Encoded Data
O	Output	SS	Sensor / Signal Supply V	S	SCP Network	V	Voltage (DC)
B+	Battery Voltage	SG	Sensor / Signal Ground	D2	D2B Network	PWM	Pulse Width Modulated

CAUTION: The information on this data page is furnished to aid the user in understanding circuit operation. THIS INFORMATION SHOULD BE USED FOR REFERENCE ONLY.

NOTE: The values listed are approximately those that can be expected at the control module connector pins with all circuit connections made and all components connected and fitted.

COMPONENTS

Component	Connector(s)	Connector Description	Location
COLUMN AND PEDAL ADJUST SWITCH	FC45	8-WAY / BLACK	STEERING COLUMN COWLING
DOOR LATCH ASSEMBLY - DRIVER	DT5	10-WAY / BLACK	DRIVER DOOR
DOOR SWITCH PACK - DRIVER	DD2	26-WAY / YELLOW	DRIVER DOOR ARM REST
DRIVER DOOR MODULE	CA85	12-WAY / BLACK	DRIVER DOOR
	DD4	26-WAY / NATURAL	
	DT2	20-WAY / BLACK	
FRONT ELECTRONIC MODULE	CA24	26-WAY / NATURAL	LH 'A' POST
	CA31	20-WAY / BLACK	
	FH9	22-WAY / BLACK	
	FH59	12-WAY / BLACK	
	FH60	17-WAY / BLACK	
INSTRUMENT CLUSTER	FC8	32-WAY / BLACK	INSTRUMENT PANEL
	FC9	32-WAY / BLACK	
PEDAL ADJUST MOTOR	CA234	2-WAY / BLACK	PEDAL MOUNTING BRACKET ASSEMBLY
	CA235	3-WAY / BLACK	
STEERING COLUMN MOTOR, SOLENOIDS AND POSITION SENSORS	FC115	10-WAY / BLACK	UPPER STEERING COLUMN

HARNES IN-LINE CONNECTORS

Connector	Connector Description / Location	Location
DD8	16-WAY / BLUE / CABIN HARNESS TO DRIVER DOOR HARNESS	DRIVER DOOR
DT8	14-WAY / GREY / CABIN HARNESS TO DRIVER DOOR TRIM HARNESS	DRIVER DOOR
FC4	14-WAY / GREEN / FASCIA HARNESS IN-LINE CONNECTOR	BEHIND INSTRUMENT PANEL, LH SIDE

GROUNDS

Ground	Location
CA30	LH LOWER 'A' POST, ADJACENT TO THE FRONT ELECTRONIC MODULE (REARWARD OF FH77)
CA50	RH LOWER 'A' POST, BELOW PRIMARY JUNCTION FUSE BOX
FC38	UNDER CENTER OF INSTRUMENT PANEL, ON TRANSMISSION TUNNEL
FH77	LH LOWER 'A' POST, ADJACENT TO THE FRONT ELECTRONIC MODULE (FORWARD OF CA30)

FOR CONTROL MODULE PIN-OUT INFORMATION, UNFOLD PAGE TO LEFT.

Refer to the front of this book for detailed information and illustrations regarding the location and identification of harnesses, relays, fuses, grounds, control modules and control module pins.

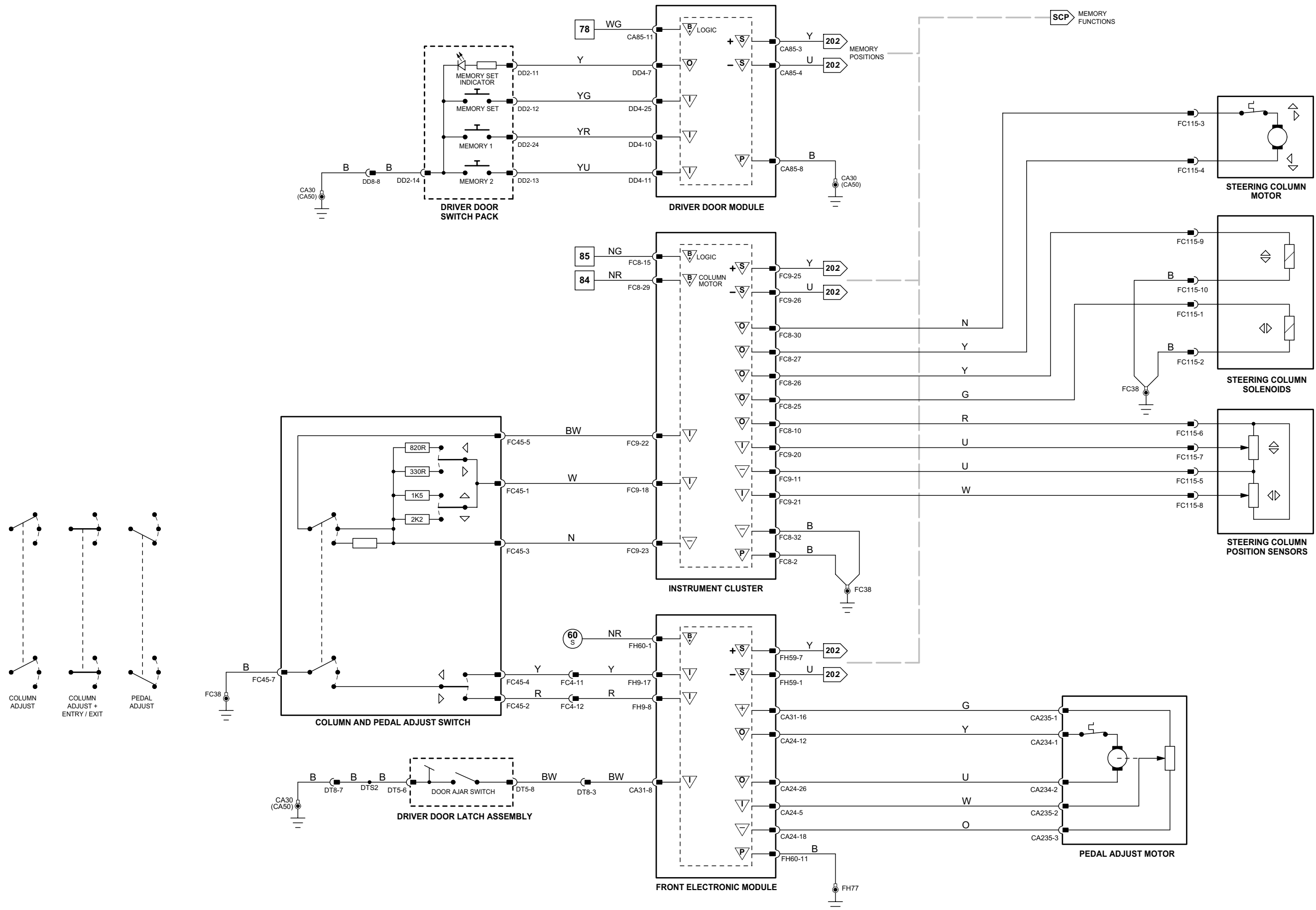

1 → 3
Fig. 01.1

4 → 76
Fig. 01.2

77 → 92
Fig. 01.3

1 → 14
Fig. 01.4

15 → 45
Fig. 01.5

46 → 80
Fig. 01.8

81 → 118
Fig. 01.7

Input
Output

Battery Voltage
Power Ground

Sensor/Signal Supply V
Sensor/Signal Ground

+

CAN
SCP

D2B Network
Serial and Encoded Data

VARIANT: All Vehicles
VIN RANGE: All
DATE OF ISSUE: April 2006

Air Conditioning Control Module – Panel

	Pin	Description and Characteristic
C	FC28-1	CAN –
C	FC28-12	CAN

Air Conditioning Control Module – Remote

	Pin	Description and Characteristic
C	FC41-1	CAN –
C	FC41-12	CAN +

Driver Door Module

	Pin	Description and Characteristic
S	CA85-3	SCP +
S	CA85-4	SCP –
PG	CA85-7	POWER GROUND: GROUND
PG	CA85-8	POWER GROUND: GROUND
B+	CA85-11	BATTERY POWER SUPPLY: B+
B+	CA85-12	SWITCHED SYSTEM POWER SUPPLY: B+
I	DD4-3	MIRROR MOVEMENT UP: GROUND WHEN ACTIVATED
O	DD4-7	MEMORY SET INDICATOR: TO ACTIVATE, DDM SWITCHES CIRCUIT TO B+
I	DD4-10	MEMORY 1: GROUND WHEN SELECTED
I	DD4-11	MEMORY 2: GROUND WHEN SELECTED
I	DD4-19	MIRROR MOVEMENT RIGHT: GROUND WHEN ACTIVATED
I	DD4-20	MIRROR MOVEMENT DOWN: GROUND WHEN ACTIVATED
I	DD4-21	MIRROR MOVEMENT LEFT: GROUND WHEN ACTIVATED
I	DD4-23	LH DOOR MIRROR MOVEMENT SELECT: GROUND WHEN SELECTED
I	DD4-24	RH DOOR MIRROR MOVEMENT SELECT: GROUND WHEN SELECTED
I	DD4-25	MEMORY SET: GROUND WHEN SELECTED
O	DT2-1	DRIVER DOOR MIRROR LEFT: TO ACTIVATE, DDM SWITCHES CIRCUIT TO B+
O	DT2-2	DRIVER DOOR MIRROR RIGHT: TO ACTIVATE, DDM SWITCHES CIRCUIT TO B+
O	DT2-3	DRIVER DOOR MIRROR UP: TO ACTIVATE, DDM SWITCHES CIRCUIT TO B+
O	DT2-4	DRIVER DOOR MIRROR DOWN: TO ACTIVATE, DDM SWITCHES CIRCUIT TO B+
SS	DT2-5	DRIVER DOOR MIRROR POSITION SENSORS SIGNAL SUPPLY VOLTAGE: B+
I	DT2-14	DRIVER DOOR MIRROR LEFT / RIGHT POSITION FEEDBACK SIGNAL: VARIABLE VOLTAGE
I	DT2-15	DRIVER DOOR MIRROR UP / DOWN POSITION FEEDBACK SIGNAL: VARIABLE VOLTAGE
SG	DT2-19	DRIVER DOOR MIRROR POSITION SENSORS SIGNAL GROUND: GROUND

Front Electronic Module

	Pin	Description and Characteristic
I	CA24-7	PASSENGER DOOR MIRROR LEFT / RIGHT POSITION FEEDBACK SIGNAL: VARIABLE VOLTAGE
SS	CA24-8	PASSENGER DOOR MIRROR POSITION SENSORS SIGNAL SUPPLY VOLTAGE: B+
I	CA24-11	PASSENGER DOOR MIRROR UP / DOWN POSITION FEEDBACK: VARIABLE VOLTAGE
O	CA24-20	PASSENGER DOOR MIRROR UP: TO ACTIVATE, FEM SWITCHES CIRCUIT TO B+
O	CA24-21	PASSENGER DOOR MIRROR DOWN: TO ACTIVATE, FEM SWITCHES CIRCUIT TO B+
SG	CA24-22	PASSENGER DOOR MIRROR POSITION SENSORS SIGNAL GROUND: GROUND
O	CA24-23	PASSENGER DOOR MIRROR LEFT: TO ACTIVATE, DDM SWITCHES CIRCUIT TO B+
O	CA24-24	PASSENGER DOOR MIRROR RIGHT: TO ACTIVATE, DDM SWITCHES CIRCUIT TO B+
S	FH59-1	SCP –
S	FH59-7	SCP +
B+	FH60-1	SWITCHED SYSTEM POWER SUPPLY: B+
PG	FH60-11	POWER GROUND: GROUND

Instrument Cluster

	Pin	Description and Characteristic
S	FC9-25	SCP +
S	FC9-26	SCP –
C	FC9-28	CAN +
C	FC9-29	CAN –

Rear Electronic Module

	Pin	Description and Characteristic
B+	CA101-3	BATTERY POWER SUPPLY: B+
S	CA102-1	SCP +
S	CA102-2	SCP –
O	CA102-7	HEATED REAR WINDOW ACTIVATE: TO ACTIVATE, REM SWITCHES CIRCUIT TO GROUND
PG	CA102-12	POWER GROUND: GROUND
B+	CA103-13	SWITCHED SYSTEM POWER SUPPLY: B+

The following abbreviations are used to represent values for Control Module Pin-Out data

I	Input	PG	Power Ground	C	CAN Network	D	Serial and Encoded Data
O	Output	SS	Sensor / Signal Supply V	S	SCP Network	V	Voltage (DC)
B+	Battery Voltage	SG	Sensor / Signal Ground	D2	D2B Network	PWM	Pulse Width Modulated

CAUTION: The information on this data page is furnished to aid the user in understanding circuit operation. THIS INFORMATION SHOULD BE USED FOR REFERENCE ONLY.

NOTE: The values listed are approximately those that can be expected at the control module connector pins with all circuit connections made and all components connected and fitted.

Fig. 10.2

COMPONENTS

Component	Connector(s)	Connector Description	Location
AIR CONDITIONING CONTROL MODULE – PANEL	FC27	26-WAY / GREY	CENTER CONSOLE
	FC28	22-WAY / GREY	
AIR CONDITIONING CONTROL MODULE – REMOTE	FC40	26-WAY / GREY	BEHIND INSTRUMENT PANEL, RH SIDE (LHD), LH SIDE (RHD)
	FC41	22-WAY / GREY	
DOOR MIRROR – DRIVER	DT6	22-WAY / BLACK	DRIVER DOOR
DOOR MIRROR – PASSENGER	CA19	22-WAY / BLACK	PASSENGER DOOR
DOOR SWITCH PACK – DRIVER	DD2	26-WAY / YELLOW	DRIVER DOOR ARM REST
DRIVER DOOR MODULE	CA85	12-WAY / BLACK	DRIVER DOOR
	DD4	26-WAY / NATURAL	
	DT2	20-WAY / BLACK	
FRONT ELECTRONIC MODULE	CA24	26-WAY / NATURAL	LH 'A' POST
	CA31	20-WAY / BLACK	
	FH9	22-WAY / BLACK	
	FH59	12-WAY / BLACK	
	FH60	17-WAY / BLACK	
HEATED REAR WINDOW	CA20	2-WAY / GREY	CONNECTOR LOCATED BELOW PARCEL SHELF, LH SIDE
HEATED REAR WINDOW RELAY	—	—	REAR POWER DISTRIBUTION FUSE BOX – R1
INSTRUMENT CLUSTER	FC8	32-WAY / BLACK	INSTRUMENT PANEL
	FC9	32-WAY / BLACK	
REAR ELECTRONIC MODULE	CA63	17-WAY / BLACK	LUGGAGE COMPARTMENT, RH REAR
	CA100	12-WAY / BLACK	
	CA101	20-WAY / BLACK	
	CA102	22-WAY / BLACK	
	CA103	26-WAY / NATURAL	
REAR POWER DISTRIBUTION FUSE BOX	—	—	LUGGAGE COMPARTMENT

HARNES IN-LINE CONNECTORS

Connector	Connector Description / Location	Location
DD8	16-WAY / BLUE / CABIN HARNESS TO DRIVER DOOR HARNESS	DRIVER DOOR
DT8	14-WAY / GREY / CABIN HARNESS TO DRIVER DOOR TRIM HARNESS	DRIVER DOOR

GROUNDS

Ground	Location
CA30	LH LOWER 'A' POST, ADJACENT TO THE FRONT ELECTRONIC MODULE (REARWARD OF FH77)
CA50	RH LOWER 'A' POST, BELOW PRIMARY JUNCTION FUSE BOX
CA156	LUGGAGE COMPARTMENT, RH SIDE
FH77	LH LOWER 'A' POST, ADJACENT TO THE FRONT ELECTRONIC MODULE (FORWARD OF CA30)

FOR CONTROL MODULE PIN-OUT INFORMATION, UNFOLD PAGE TO LEFT.

Refer to the front of this book for detailed information and illustrations regarding the location and identification of harnesses, relays, fuses, grounds, control modules and control module pins.

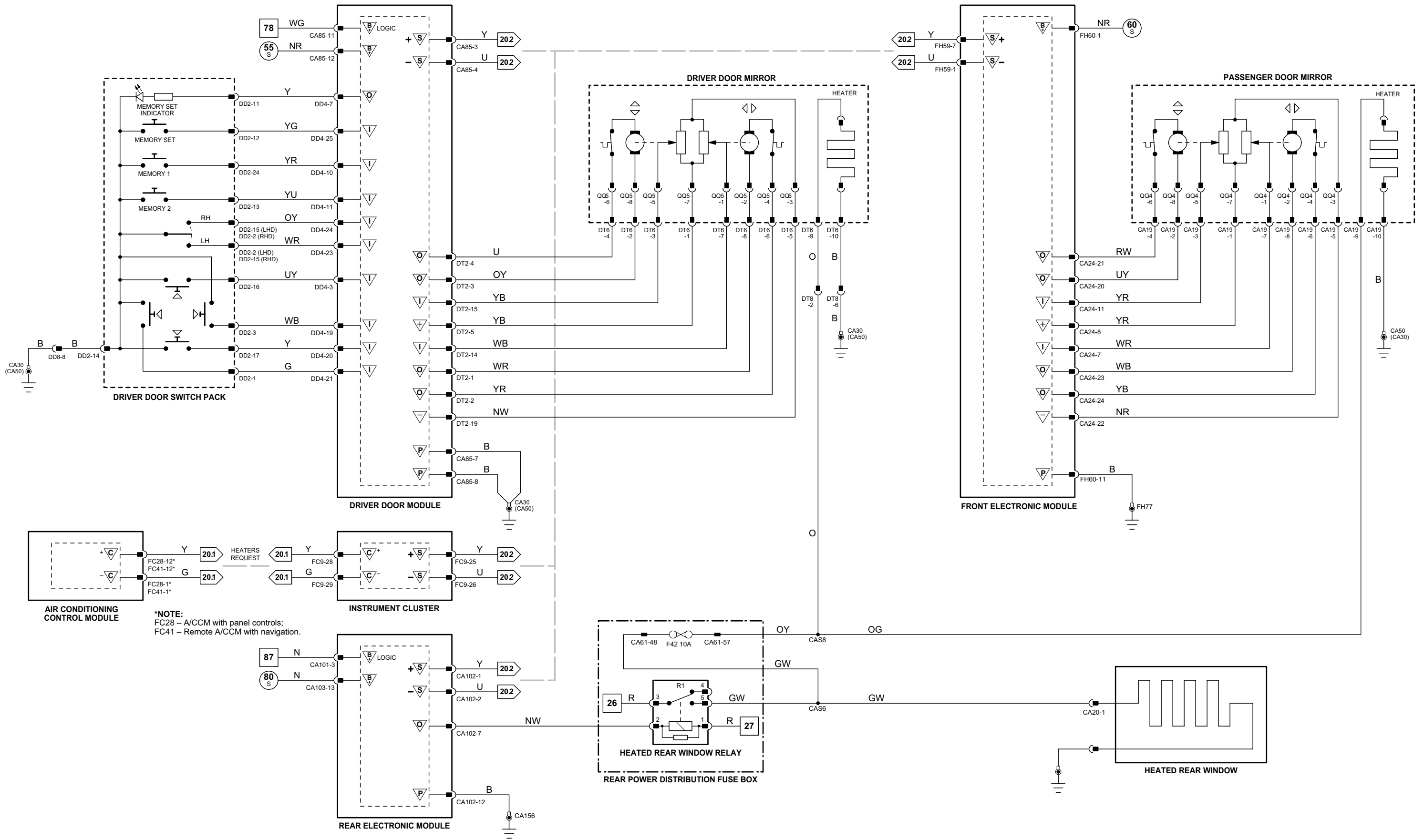

Fig. 10.3

Driver Door Module

	Pin	Description and Characteristic
O	CA85-5	MIRROR FOLD FLAT DRIVE: TO ACTIVATE, DDM SWITCHES CIRCUIT TO B+
O	CA85-6	MIRROR FOLD FLAT DRIVE: TO ACTIVATE, DDM SWITCHES CIRCUIT TO B+
PG	CA85-7	POWER GROUND: GROUND
PG	CA85-8	POWER GROUND: GROUND
B+	CA85-11	BATTERY POWER SUPPLY: B+
B+	CA85-12	SWITCHED SYSTEM POWER SUPPLY: B+
I	DD4-20	MIRROR FOLD FLAT (MIRROR SELECT IN NEUTRAL POSITION): GROUND WHEN ACTIVATED
I	DD4-23	LH DOOR MIRROR MOVEMENT SELECT: GROUND WHEN SELECTED
I	DD4-24	RH DOOR MIRROR MOVEMENT SELECT: GROUND WHEN SELECTED

Rear Electronic Module

	Pin	Description and Characteristic
B+	CA101-3	BATTERY POWER SUPPLY: B+
S	CA102-1	SCP +
S	CA102-2	SCP -
O	CA102-4	ELECTROCHROMATIC REAR VIEW MIRROR DEACTIVATE (REM REVERSE SIGNAL): TO ACTIVATE, REM SWITCHES CIRCUIT TO B+
PG	CA102-12	POWER GROUND: GROUND
B+	CA103-13	SWITCHED SYSTEM POWER SUPPLY: B+

COMPONENTS

Component	Connector(s)	Connector Description	Location
DOOR MIRROR - DRIVER	DT6	22-WAY / BLACK	DRIVER DOOR
DOOR MIRROR - PASSENGER	CA19	22-WAY / BLACK	PASSENGER DOOR
DOOR SWITCH PACK - DRIVER	DD2	26-WAY / YELLOW	DRIVER DOOR ARM REST
DRIVER DOOR MODULE	CA85	12-WAY / BLACK	DRIVER DOOR
	DD4	26-WAY / NATURAL	
	DT2	20-WAY / BLACK	
ELECTROCHROMIC REAR VIEW MIRROR AND COMPASS	RF5	6-WAY / BLACK	WINDSHIELD, CENTER
REAR ELECTRONIC MODULE	CA63	17-WAY / BLACK	LUGGAGE COMPARTMENT, RH REAR
	CA100	12-WAY / BLACK	
	CA101	20-WAY / BLACK	
	CA102	22-WAY / BLACK	
	CA103	26-WAY / NATURAL	

HARNESS IN-LINE CONNECTORS

Connector	Connector Description / Location	Location
DD8	16-WAY / BLUE / CABIN HARNESS TO DRIVER DOOR HARNESS	DRIVER DOOR
DT10	10-WAY / GREY / CABIN HARNESS TO DRIVER DOOR TRIM HARNESS	DRIVER DOOR
RF34	16-WAY / GREEN / CABIN HARNESS TO DOOR HARNESS	'D' POST, UNDER PARCEL SHELF

GROUNDS

Ground	Location
CA30	LH LOWER 'A' POST, ADJACENT TO THE GENERAL ELECTRONIC CONTROL MODULE (REARWARD OF FH77)
CA50	RH LOWER 'A' POST, BELOW PRIMARY JUNCTION FUSE BOX
CA116	BEHIND REAR SEAT BACK, RH SIDE
CA156	LUGGAGE COMPARTMENT, RH SIDE

FOR CONTROL MODULE PIN-OUT INFORMATION, UNFOLD PAGE TO LEFT.

The following abbreviations are used to represent values for Control Module Pin-Out data

I	Input	PG	Power Ground	C	CAN Network	D	Serial and Encoded Data
O	Output	SS	Sensor / Signal Supply V	S	SCP Network	V	Voltage (DC)
B+	Battery Voltage	SG	Sensor / Signal Ground	D2	D2B Network	PWM	Pulse Width Modulated

CAUTION: The information on this data page is furnished to aid the user in understanding circuit operation. THIS INFORMATION SHOULD BE USED FOR REFERENCE ONLY.

NOTE: The values listed are approximately those that can be expected at the control module connector pins with all circuit connections made and all components connected and fitted.

Refer to the front of this book for detailed information and illustrations regarding the location and identification of harnesses, relays, fuses, grounds, control modules and control module pins.

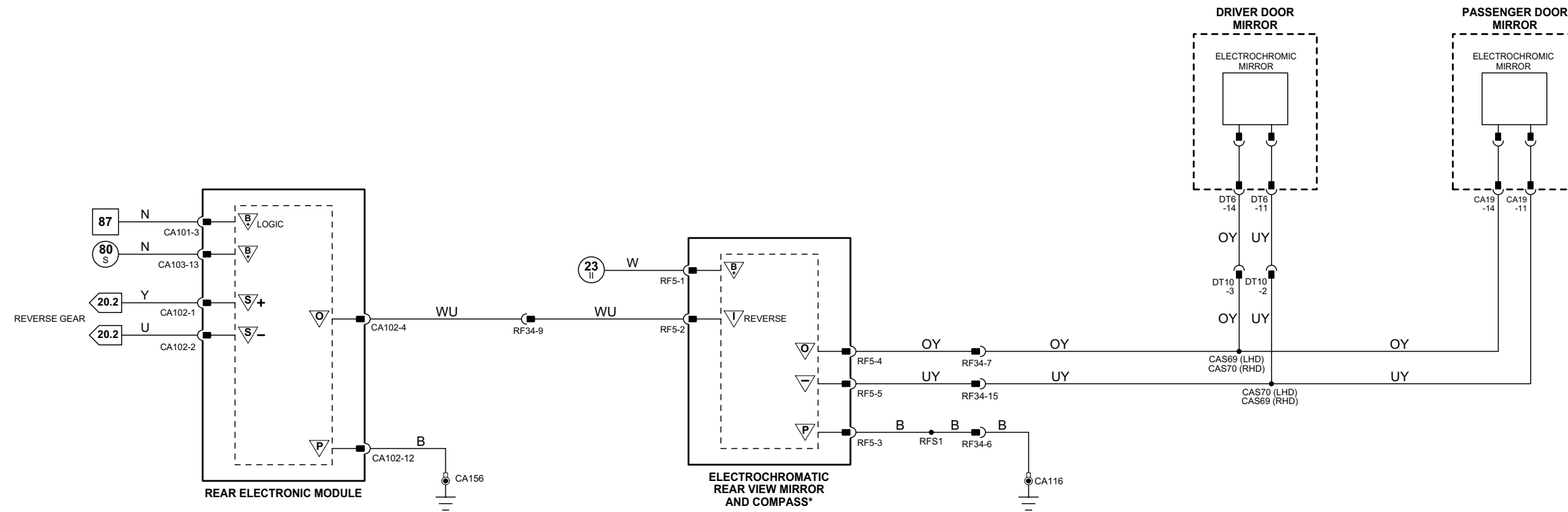

* NOTE: Includes compass, when fitted.

ELECTROCHROMIC REAR VIEW MIRRORS

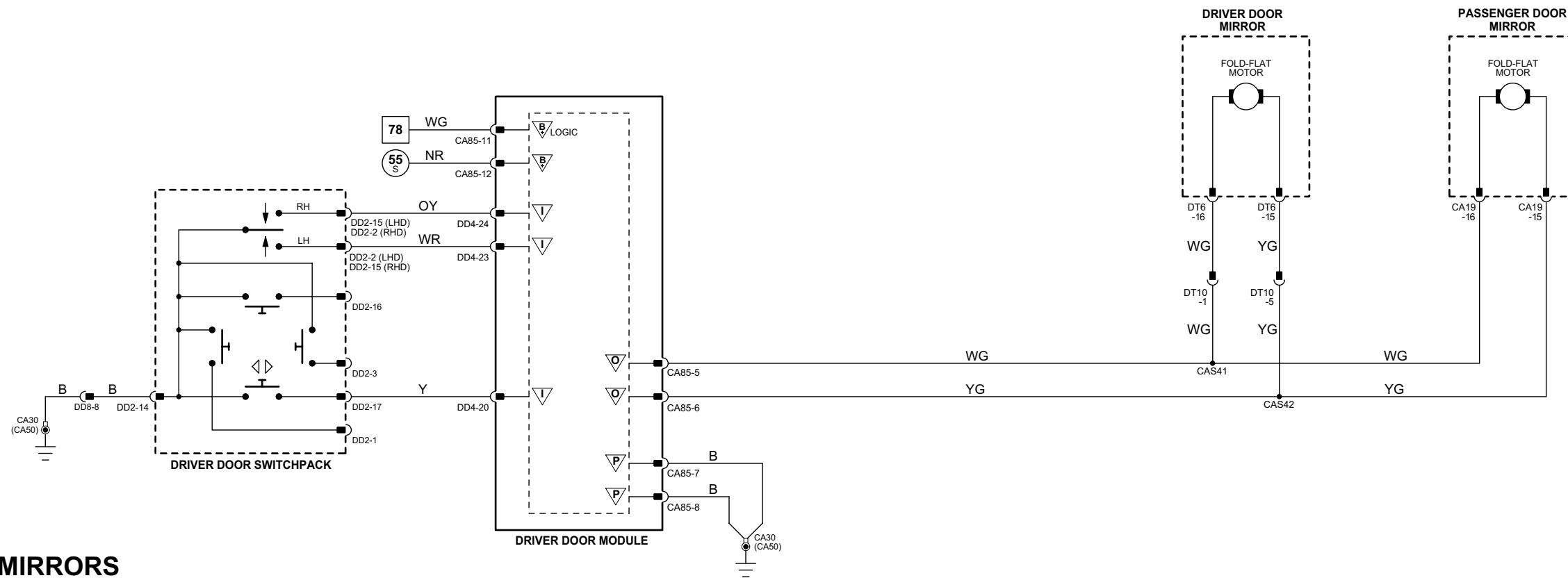

FOLD-BACK MIRRORS



VARIANT: All Vehicles; Fold-Back Mirror Vehicles
 VIN RANGE: All
 DATE OF ISSUE: April 2006

Fig. 11.1

Driver Door Module

	Pin	Description and Characteristic
S	CA85-3	SCP +
S	CA85-4	SCP -
PG	CA85-8	POWER GROUND: GROUND
B+	CA85-11	BATTERY POWER SUPPLY: B+
O	DD4-7	MEMORY SET INDICATOR: TO ACTIVATE, DDM SWITCHES CIRCUIT TO B+
I	DD4-10	MEMORY 1: GROUND WHEN SELECTED
I	DD4-11	MEMORY 2: GROUND WHEN SELECTED
I	DD4-25	MEMORY SET: GROUND WHEN SELECTED

Driver Seat Module

	Pin	Description and Characteristic
I	DM33-7	SEAT CUSHION FRONT POSITION SENSOR SIGNAL: 5 V PULSED SIGNAL
I	DM33-8	SEAT HEIGHT POSITION SENSOR SIGNAL: 5 V PULSED SIGNAL
I	DM33-10	SEAT BACK RECLINE POSITION SENSOR SIGNAL: 5 V PULSED SIGNAL
SG	DM33-11	SIGNAL GROUND: GROUND
B+	DM33-13	BATTERY POWER SUPPLY: LOGIC: B+
I	DM33-22	SEAT POSITION SENSOR SIGNAL: 5 V PULSED SIGNAL
SG	DM33-25	SIGNAL GROUND: GROUND
SG	DM33-26	LOGIC GROUND: GROUND
S	DM34-1	SCP +
I	DM34-4	SEAT CUSHION FRONT RAISE REQUEST: ACTIVE = B+
I	DM34-5	SEAT CUSHION FRONT LOWER REQUEST: ACTIVE = B+
I	DM34-10	SEAT BACK RECLINE REARWARD REQUEST: ACTIVE = B+
I	DM34-11	SEAT BACK RECLINE FORWARD REQUEST: ACTIVE = B+
S	DM34-12	SCP -
I	DM34-17	SEAT RAISE REQUEST: ACTIVE = B+
I	DM34-18	SEAT LOWER REQUEST: ACTIVE = B+
I	DM34-19	SEAT FORWARD REQUEST: ACTIVE = B+
I	DM34-20	SEAT REARWARD REQUEST: ACTIVE = B+
O	DM35-1	SEAT HEIGHT MOTOR DRIVE - RAISE: TO ACTIVATE, DSM SWITCHES CIRCUIT TO B+
O	DM35-2	SEAT HEIGHT MOTOR DRIVE - LOWER: TO ACTIVATE, DSM SWITCHES CIRCUIT TO B+
PG	DM35-5	POWER GROUND: GROUND
B+	DM35-6	BATTERY POWER SUPPLY: B+
O	DM36-1	SEAT POSITION MOTOR DRIVE - FORWARD: TO ACTIVATE, DSM SWITCHES CIRCUIT TO B+
O	DM36-2	SEAT POSITION MOTOR DRIVE - REARWARD: TO ACTIVATE, DSM SWITCHES CIRCUIT TO B+
O	DM37-3	SEAT BACK RECLINE MOTOR DRIVE - REARWARD: TO ACTIVATE, DSM SWITCHES CIRCUIT TO B+
O	DM37-4	SEAT BACK RECLINE MOTOR DRIVE - FORWARD: TO ACTIVATE, DSM SWITCHES CIRCUIT TO B+
PG	DM38-1	POWER GROUND: GROUND
B+	DM38-2	BATTERY POWER SUPPLY: B+
O	DM38-5	SEAT CUSHION FRONT MOTOR DRIVE - RAISE: TO ACTIVATE, DSM SWITCHES CIRCUIT TO B+
O	DM38-6	SEAT CUSHION FRONT MOTOR DRIVE - LOWER: TO ACTIVATE, DSM SWITCHES CIRCUIT TO B+

COMPONENTS

Component	Connector(s)	Connector Description	Location
DOOR SWITCH PACK - DRIVER	DD2	26-WAY / YELLOW	DRIVER DOOR ARM REST
DRIVER DOOR MODULE	CA85	12-WAY / BLACK	DRIVER DOOR
	DD4	26-WAY / NATURAL	
	DT2	20-WAY / BLACK	
DRIVER SEAT MODULE	DM33	26-WAY / BLACK	UNDER DRIVER SEAT
	DM34	22-WAY / BLACK	
	DM35	6-WAY / BLACK	
	DM36	4-WAY / BLACK	
	DM37	4-WAY / BLACK	
	DM38	6-WAY / BLACK	
LUMBAR PUMP - DRIVER	DL4	3-WAY / BLACK	LOWER SEAT BACK
SEAT MOTORS AND POSITION SENSORS - DRIVER	DM25	4-WAY / BLACK	DRIVER SEAT
	DM26	4-WAY / BLACK	
	DM27	4-WAY / BLACK	
	DM28	4-WAY / BLACK	
	DM29	4-WAY / BLACK	
	DM31	4-WAY / BLACK	
SEAT SWITCH PACK - DRIVER	DM7	12-WAY / BLACK	DRIVER SEAT
	DM43	14-WAY / BLACK	

HARNESS IN-LINE CONNECTORS

Connector	Connector Description / Location	Location
DD8	16-WAY / BLUE / CABIN HARNESS TO DRIVER DOOR HARNESS	DRIVER DOOR
DL2	6-WAY / BLACK / DRIVER SEAT IN-LINE CONNECTOR	DRIVER SEAT BACK REST
DM22	4-WAY / GREY / CABIN HARNESS TO DRIVER SEAT HARNESS	UNDER DRIVER SEAT
DM23	20-WAY / BLACK / CABIN HARNESS TO DRIVER SEAT HARNESS	UNDER DRIVER SEAT

GROUNDS

Ground	Location
CA30	LH LOWER 'A' POST, ADJACENT TO THE FRONT ELECTRONIC MODULE (REARWARD OF FH77)
CA50	RH LOWER 'A' POST, BELOW PRIMARY JUNCTION FUSE BOX
CA141	UNDER LH FRONT SEAT
CA154	UNDER RH FRONT SEAT

FOR CONTROL MODULE PIN-OUT INFORMATION, UNFOLD PAGE TO LEFT.

The following abbreviations are used to represent values for Control Module Pin-Out data

I	Input	PG	Power Ground	C	CAN Network	D	Serial and Encoded Data
O	Output	SS	Sensor / Signal Supply V	S	SCP Network	V	Voltage (DC)
B+	Battery Voltage	SG	Sensor / Signal Ground	D2	D2B Network	PWM	Pulse Width Modulated

CAUTION: The information on this data page is furnished to aid the user in understanding circuit operation. THIS INFORMATION SHOULD BE USED FOR REFERENCE ONLY.

NOTE: The values listed are approximately those that can be expected at the control module connector pins with all circuit connections made and all components connected and fitted.

Refer to the front of this book for detailed information and illustrations regarding the location and identification of harnesses, relays, fuses, grounds, control modules and control module pins.

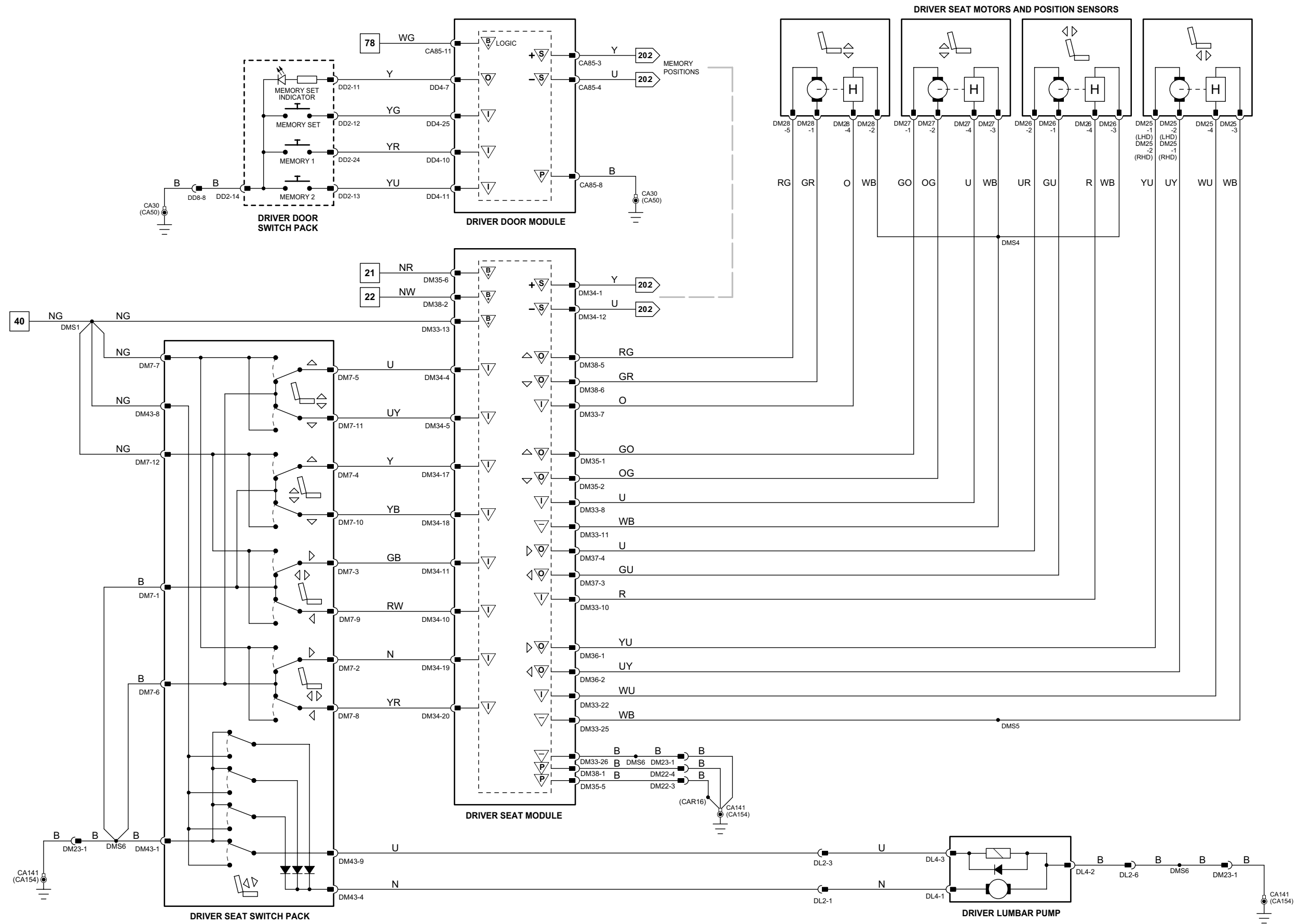

Driver Seat Module

Pin	Description and Characteristic
I	DM33-7 SEAT CUSHION FRONT POSITION SENSOR SIGNAL: 5 V PULSED SIGNAL
I	DM33-8 SEAT HEIGHT POSITION SENSOR SIGNAL: 5 V PULSED SIGNAL
I	DM33-9 HEADREST POSITION SENSOR SIGNAL: 5 V PULSED SIGNAL
I	DM33-10 SEAT BACK RECLINE POSITION SENSOR SIGNAL: 5 V PULSED SIGNAL
SG	DM33-11 SIGNAL GROUND: GROUND
SG	DM33-12 SIGNAL GROUND: GROUND
B+	DM33-13 BATTERY POWER SUPPLY: LOGIC: B+
I	DM33-22 SEAT POSITION SENSOR SIGNAL: 5 V PULSED SIGNAL
I	DM33-23 SEAT CUSHION EXTEND POSITION SENSOR SIGNAL: 5 V PULSED SIGNAL
SG	DM33-25 SIGNAL GROUND: GROUND
SG	DM33-26 LOGIC GROUND: GROUND
S	DM34-1 SCP +
I	DM34-4 SEAT CUSHION FRONT RAISE REQUEST: ACTIVE = B+
I	DM34-5 SEAT CUSHION FRONT LOWER REQUEST: ACTIVE = B+
I	DM34-10 SEAT BACK RECLINE REARWARD REQUEST: ACTIVE = B+
I	DM34-11 SEAT BACK RECLINE FORWARD REQUEST: ACTIVE = B+
S	DM34-12 SCP -
I	DM34-15 HEAD REST RAISE REQUEST: ACTIVE = B+
I	DM34-16 HEADREST LOWER REQUEST: ACTIVE = B+
I	DM34-17 SEAT RAISE REQUEST: ACTIVE = B+
I	DM34-18 SEAT LOWER REQUEST: ACTIVE = B+
I	DM34-19 SEAT FORWARD REQUEST: ACTIVE = B+
I	DM34-20 SEAT REARWARD REQUEST: ACTIVE = B+
I	DM34-21 SEAT CUSHION EXTEND REARWARD REQUEST: ACTIVE = B+
I	DM34-22 SEAT CUSHION EXTEND FORWARD REQUEST: ACTIVE = B+
O	DM35-1 SEAT HEIGHT MOTOR DRIVE - RAISE: TO ACTIVATE, DSM SWITCHES CIRCUIT TO B+
O	DM35-2 SEAT HEIGHT MOTOR DRIVE - LOWER: TO ACTIVATE, DSM SWITCHES CIRCUIT TO B+
PG	DM35-5 POWER GROUND: GROUND
B+	DM35-6 BATTERY POWER SUPPLY: B+
O	DM36-1 SEAT POSITION MOTOR DRIVE - FORWARD: TO ACTIVATE, DSM SWITCHES CIRCUIT TO B+
O	DM36-2 SEAT POSITION MOTOR DRIVE - REARWARD: TO ACTIVATE, DSM SWITCHES CIRCUIT TO B+
O	DM36-3 SEAT CUSHION EXTEND MOTOR DRIVE - REARWARD: TO ACTIVATE, DSM SWITCHES CIRCUIT TO B+
O	DM36-4 SEAT CUSHION EXTEND MOTOR DRIVE - FORWARD: TO ACTIVATE, DSM SWITCHES CIRCUIT TO B+
O	DM37-3 SEAT BACK RECLINE MOTOR DRIVE - REARWARD: TO ACTIVATE, DSM SWITCHES CIRCUIT TO B+
O	DM37-4 SEAT BACK RECLINE MOTOR DRIVE - FORWARD: TO ACTIVATE, DSM SWITCHES CIRCUIT TO B+
PG	DM38-1 POWER GROUND: GROUND
B+	DM38-2 BATTERY POWER SUPPLY: B+
O	DM38-3 HEADREST POSITION MOTOR DRIVE - RAISE: TO ACTIVATE, DSM SWITCHES CIRCUIT TO B+
O	DM38-4 HEADREST POSITION MOTOR DRIVE - LOWER: TO ACTIVATE, DSM SWITCHES CIRCUIT TO B+
O	DM38-5 SEAT CUSHION FRONT MOTOR DRIVE - RAISE: TO ACTIVATE, DSM SWITCHES CIRCUIT TO B+
O	DM38-6 SEAT CUSHION FRONT MOTOR DRIVE - LOWER: TO ACTIVATE, DSM SWITCHES CIRCUIT TO B+

The following abbreviations are used to represent values for Control Module Pin-Out data

I	Input	PG	Power Ground	C	CAN Network	D	Serial and Encoded Data
O	Output	SS	Sensor / Signal Supply V	S	SCP Network	V	Voltage (DC)
B+	Battery Voltage	SG	Sensor / Signal Ground	D2	D2B Network	PWM	Pulse Width Modulated

CAUTION: The information on this data page is furnished to aid the user in understanding circuit operation. THIS INFORMATION SHOULD BE USED FOR REFERENCE ONLY.

NOTE: The values listed are approximately those that can be expected at the control module connector pins with all circuit connections made and all components connected and fitted.

Fig. 11.2

COMPONENTS

Component	Connector(s)	Connector Description	Location
DRIVER SEAT MODULE	DM33	26-WAY / BLACK	UNDER DRIVER SEAT
	DM34	22-WAY / BLACK	
	DM35	6-WAY / BLACK	
	DM36	4-WAY / BLACK	
	DM37	4-WAY / BLACK	
	DM38	6-WAY / BLACK	
LUMBAR PUMP - DRIVER (16-WAY)	DL3	2-WAY / BLACK	LOWER SEAT BACK
LUMBAR SOLENOIDS - DRIVER	DL1	6-WAY / BLACK	UPPER SEAT BACK
SEAT MOTORS AND POSITION SENSORS - DRIVER	DM25	4-WAY / BLACK	DRIVER SEAT
	DM26	4-WAY / BLACK	
	DM27	4-WAY / BLACK	
	DM28	4-WAY / BLACK	
	DM29	4-WAY / BLACK	
	DM31	4-WAY / BLACK	
SEAT SWITCH PACK - DRIVER	DM7	12-WAY / BLACK	DRIVER SEAT
	DM43	14-WAY / BLACK	

HARNES IN-LINE CONNECTORS

Connector	Connector Description / Location	Location
DL2	6-WAY / BLACK / DRIVER SEAT IN-LINE CONNECTOR	DRIVER SEAT BACK REST
DM22	4-WAY / GREY / CABIN HARNESS TO DRIVER SEAT HARNESS	UNDER DRIVER SEAT
DM23	20-WAY / BLACK / CABIN HARNESS TO DRIVER SEAT HARNESS	UNDER DRIVER SEAT

GROUND S

Ground	Location
CA141	UNDER LH FRONT SEAT
CA154	UNDER RH FRONT SEAT

FOR CONTROL MODULE PIN-OUT INFORMATION, UNFOLD PAGE TO LEFT.

Refer to the front of this book for detailed information and illustrations regarding the location and identification of harnesses, relays, fuses, grounds, control modules and control module pins.

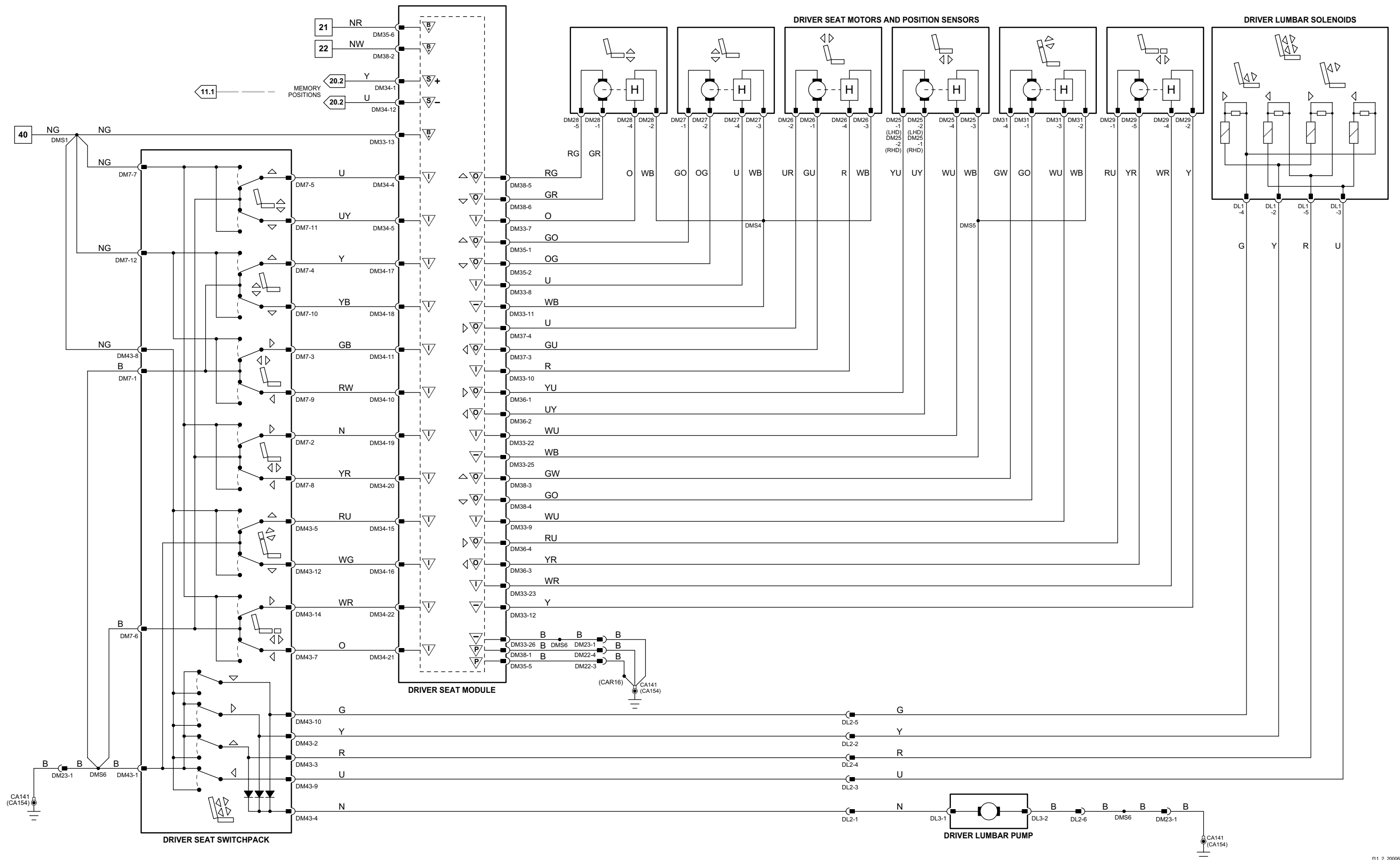

Fig. 11.3**COMPONENTS**

Component	Connector(s)	Connector Description	Location
LUMBAR PUMP – DRIVER	DL4	3-WAY / BLACK	LOWER SEAT BACK
SEAT MOTORS AND POSITION SENSORS – DRIVER	DM25	4-WAY / BLACK	DRIVER SEAT
	DM26	4-WAY / BLACK	
	DM27	4-WAY / BLACK	
	DM28	4-WAY / BLACK	
SEAT SWITCH PACK – DRIVER	DM7	12-WAY / BLACK	DRIVER SEAT
	DM39	14-WAY / BLACK	

HARNESS IN-LINE CONNECTORS

Connector	Connector Description / Location	Location
DL2	6-WAY / BLACK / DRIVER SEAT IN-LINE CONNECTOR	DRIVER SEAT BACK REST
DM22	4-WAY / GREY / CABIN HARNESS TO DRIVER SEAT HARNESS	UNDER DRIVER SEAT
DM23	20-WAY / BLACK / CABIN HARNESS TO DRIVER SEAT HARNESS	UNDER DRIVER SEAT

GROUNDS

Ground	Location
CA141	UNDER LH FRONT SEAT
CA154	UNDER RH FRONT SEAT

Refer to the front of this book for detailed information and illustrations regarding the location and identification of harnesses, relays, fuses, grounds, control modules and control module pins.

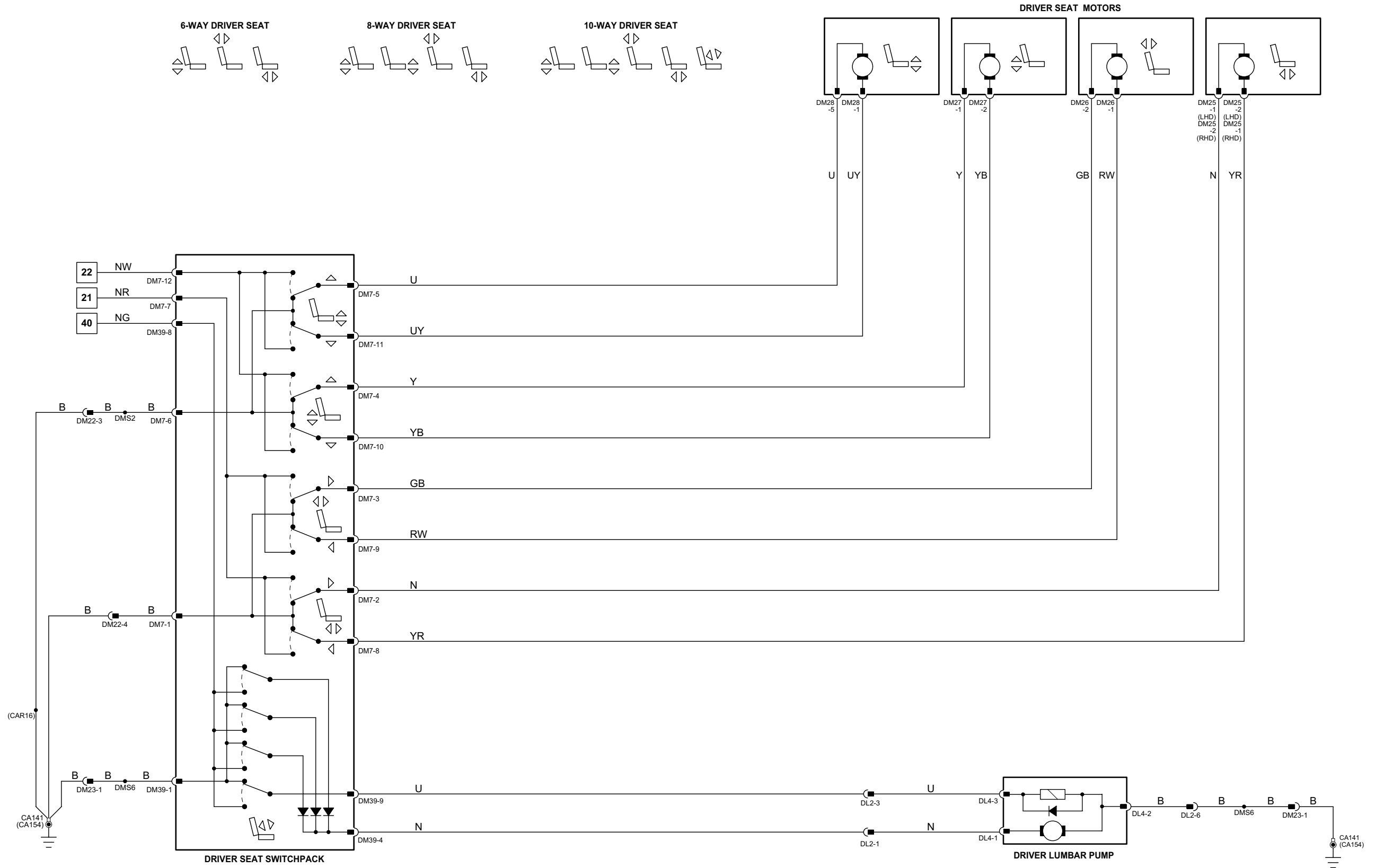

Fig. 11.4**COMPONENTS**

Component	Connector(s)	Connector Description	Location
LUMBAR PUMP – PASSENGER	PL4	3-WAY / BLACK	LOWER SEAT BACK
SEAT MOTORS – PASSENGER	PN26	4-WAY / BLACK	PASSENGER SEAT
	PN27	4-WAY / BLACK	
	PN28	4-WAY / BLACK	
	PN30	4-WAY / BLACK	
	PN4	12-WAY / BLACK	
SEAT SWITCH PACK – PASSENGER	PN39	14-WAY / BLACK	PASSENGER SEAT

HARNESS IN-LINE CONNECTORS

Connector	Connector Description / Location	Location
PL2	6-WAY / BLACK / PASSENGER SEAT IN-LINE CONNECTOR	PASSENGER SEAT BACK REST
PN23	4-WAY / GREY / CABIN HARNESS TO PASSENGER SEAT HARNESS	UNDER PASSENGER SEAT
PN24	20-WAY / BLACK / CABIN HARNESS TO PASSENGER SEAT HARNESS	UNDER PASSENGER SEAT

GROUNDS

Ground	Location
CA141	UNDER LH FRONT SEAT
CA154	UNDER RH FRONT SEAT

Refer to the front of this book for detailed information and illustrations regarding the location and identification of harnesses, relays, fuses, grounds, control modules and control module pins.

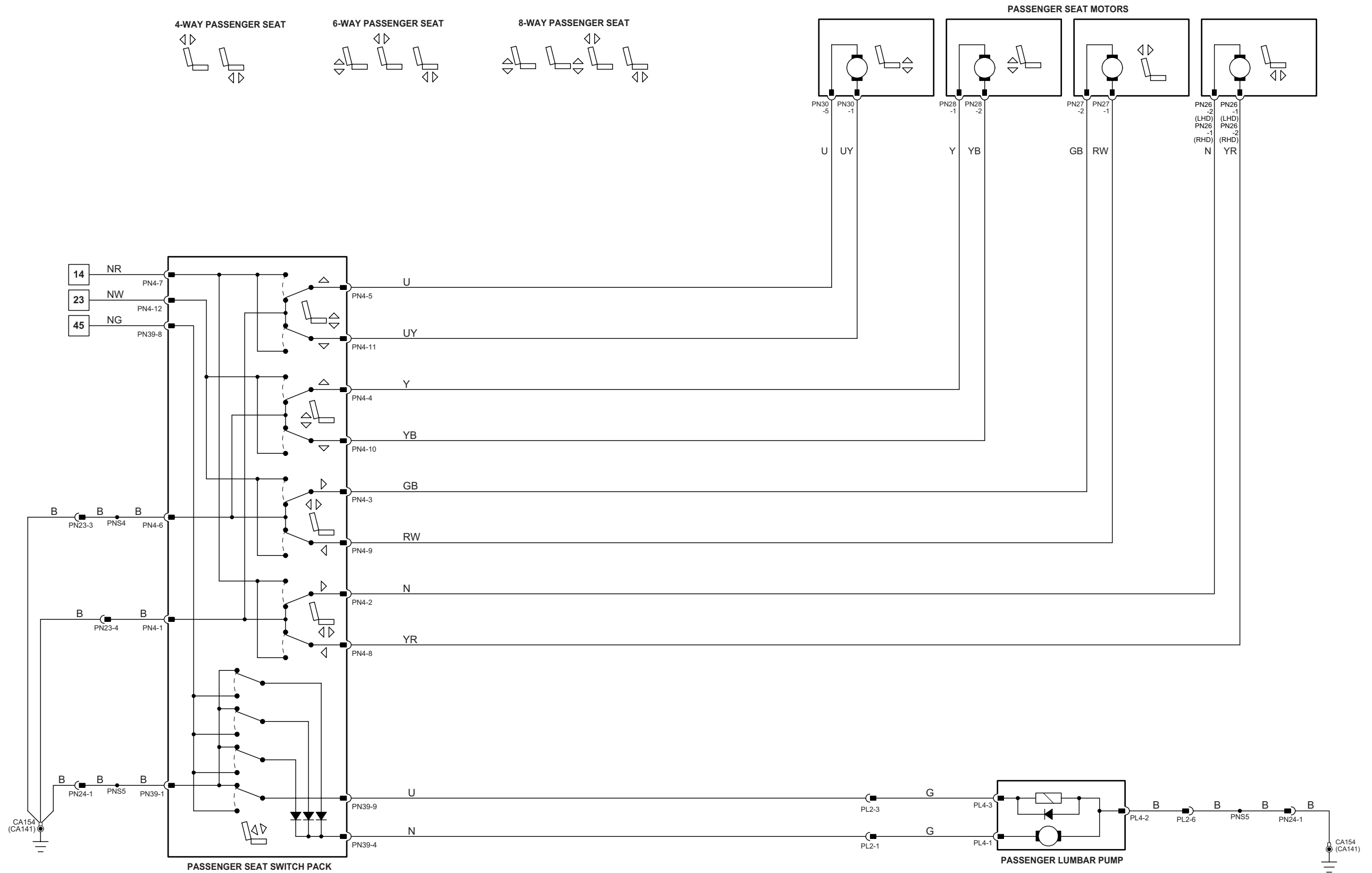

1 → 3
Fig. 01.1

4 → 76
Fig. 01.2

77 → 92
Fig. 01.3

1 → 14
Fig. 01.4

15 → 45
Fig. 01.5

46 → 80
Fig. 01.6

81 → 118
Fig. 01.7

Input
Output

B Battery Voltage
P Power Ground

∇ Sensor/Signal Supply V
∇ Sensor/Signal Ground

∇ CAN
∇ SCP
∇ D2B Network
∇ Serial and Encoded Data

VARIANT: 4 / 6 / 8 / 10-Way Passenger Seat Vehicles
VIN RANGE: All
DATE OF ISSUE: April 2006

Fig. 11.5**COMPONENTS**

Component	Connector(s)	Connector Description	Location
LUMBAR PUMP – PASSENGER (12-WAY)	PL4	3-WAY / BLACK	LOWER SEAT BACK
LUMBAR SOLENOIDS – PASSENGER	PL1	6-WAY / BLACK	UPPER SEAT BACK
SEAT MOTORS AND POSITION SENSORS – PASSENGER	PN26	4-WAY / BLACK	PASSENGER SEAT
	PN27	4-WAY / BLACK	
	PN28	4-WAY / BLACK	
	PN30	4-WAY / BLACK	
	PN31	4-WAY / BLACK	
	PN4	12-WAY / BLACK	
SEAT SWITCH PACK – PASSENGER	PN39	14-WAY / BLACK	PASSENGER SEAT

HARNESS IN-LINE CONNECTORS

Connector	Connector Description / Location	Location
PL2	6-WAY / BLACK / PASSENGER SEAT IN-LINE CONNECTOR	PASSENGER SEAT BACK REST
PN23	4-WAY / GREY / CABIN HARNESS TO PASSENGER SEAT HARNESS	UNDER PASSENGER SEAT
PN24	20-WAY / BLACK / CABIN HARNESS TO PASSENGER SEAT HARNESS	UNDER PASSENGER SEAT

GROUNDS

Ground	Location
CA141	UNDER LH FRONT SEAT
CA154	UNDER RH FRONT SEAT

Refer to the front of this book for detailed information and illustrations regarding the location and identification of harnesses, relays, fuses, grounds, control modules and control module pins.

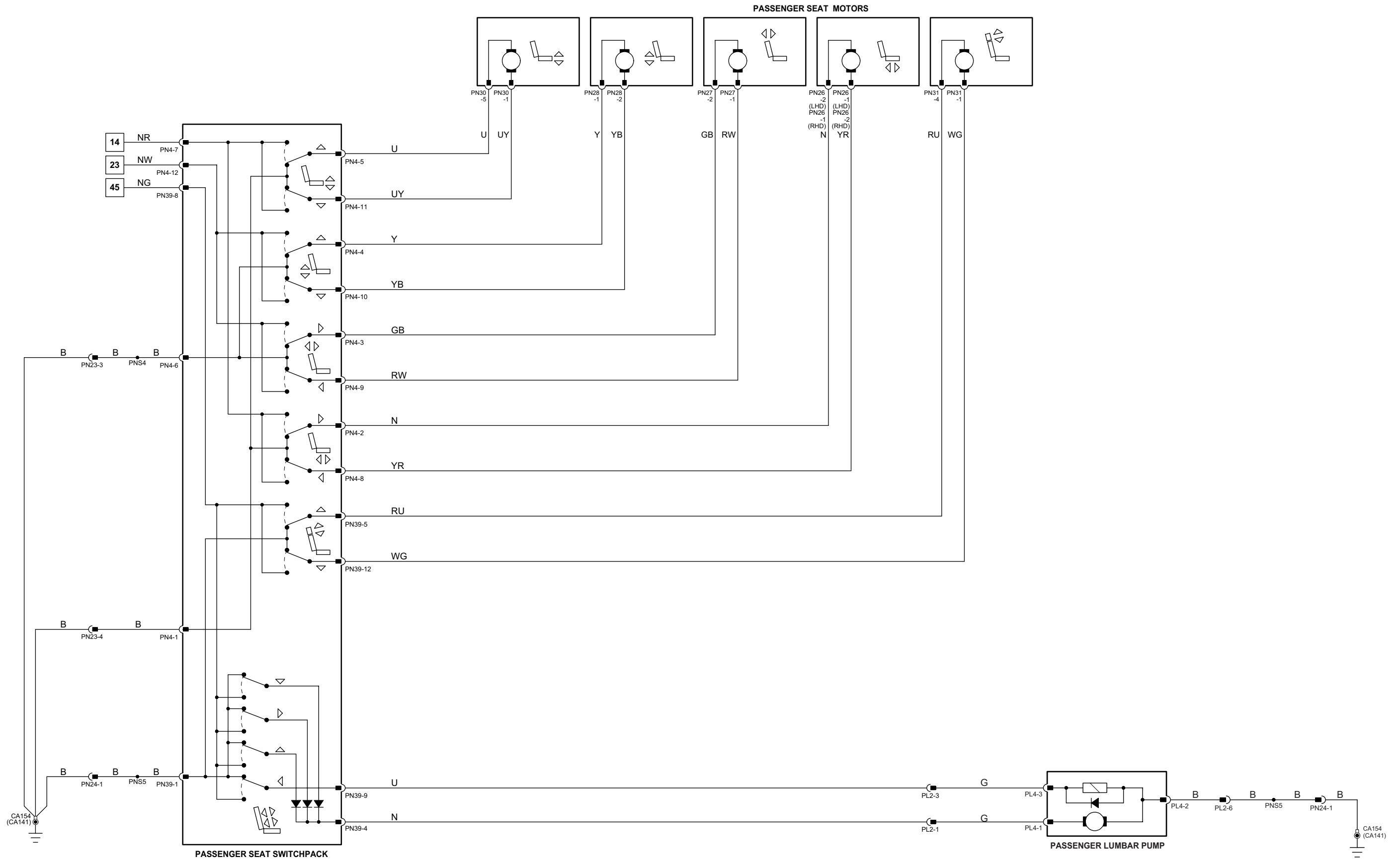

1 → 3
Fig. 01.1

4 → 76
Fig. 01.2

77 → 92
Fig. 01.3

1 → 14
Fig. 01.4

15 → 45
Fig. 01.5

46 → 80
Fig. 01.8

81 → 118
Fig. 01.7

Input
Output

B Battery Voltage
P Power Ground

+ Sensor/Signal Supply V
- Sensor/Signal Ground

C CAN
S SCP
D D2B Network
D Serial and Encoded Data

VARIANT: 12-Way Passenger Seat Vehicles
VIN RANGE: All
DATE OF ISSUE: April 2006

Fig. 11.6**COMPONENTS**

Component	Connector(s)	Connector Description	Location
CENTER CONSOLE SWITCH PACK	FC113	8-WAY / BLACK	CENTER CONSOLE
	FC119	8-WAY / BLACK	
SEAT BACK HEATER – DRIVER	DB7	2-WAY / BLACK	DRIVER SEAT BACK
SEAT BACK HEATER – PASSENGER	PB7	2-WAY / BLACK	PASSENGER SEAT BACK
SEAT CUSHION HEATER – DRIVER	DM16	4-WAY / BLACK	DRIVER SEAT CUSHION
SEAT CUSHION HEATER – PASSENGER	PN12	4-WAY / BLACK	PASSENGER SEAT CUSHION
SEAT HEATER MODULE – DRIVER	DM15	12-WAY / GREY	UNDER DRIVER SEAT
SEAT HEATER MODULE – PASSENGER	PN7	12-WAY / GREY	UNDER PASSENGER SEAT

HARNESS IN-LINE CONNECTORS

Connector	Connector Description / Location	Location
DM23	20-WAY / BLACK / CABIN HARNESS TO DRIVER SEAT HARNESS	UNDER DRIVER SEAT
FC17	16-WAY / BLUE / CABIN HARNESS TO FASCIA HARNESS	BEHIND INSTRUMENT PANEL, PASSENGER SIDE
FC26	16-WAY / BLUE / CABIN HARNESS TO FASCIA HARNESS	BEHIND INSTRUMENT PANEL, DRIVER SIDE
PN23	4-WAY / GREY / CABIN HARNESS TO PASSENGER SEAT HARNESS	UNDER PASSENGER SEAT
PN24	20-WAY / BLACK / CABIN HARNESS TO PASSENGER SEAT HARNESS	UNDER PASSENGER SEAT

GROUNDS

Ground	Location
CA141	UNDER LH FRONT SEAT
CA154	UNDER RH FRONT SEAT
FC38	UNDER CENTER OF INSTRUMENT PANEL, ON TRANSMISSION TUNNEL

Refer to the front of this book for detailed information and illustrations regarding the location and identification of harnesses, relays, fuses, grounds, control modules and control module pins.

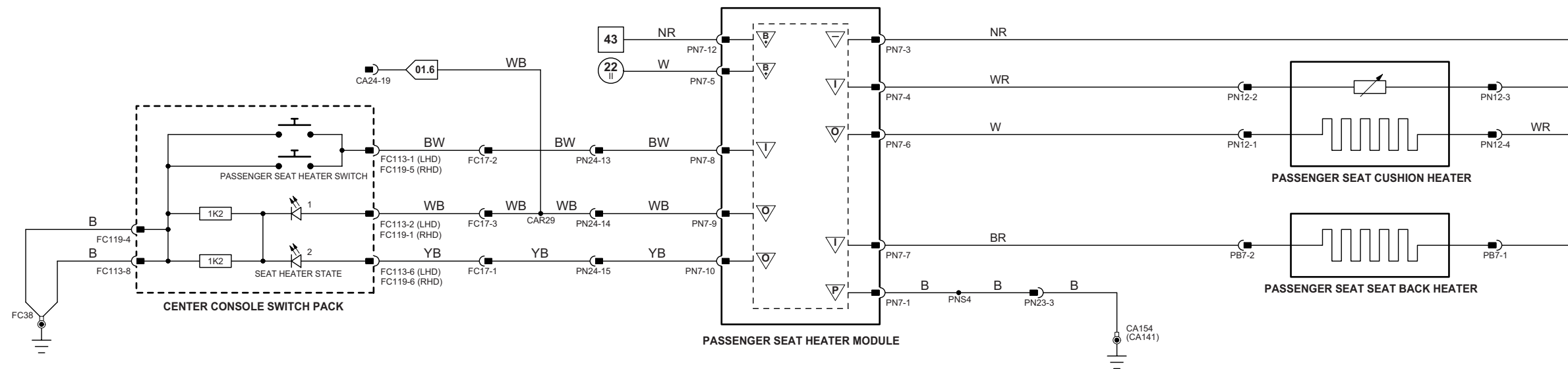
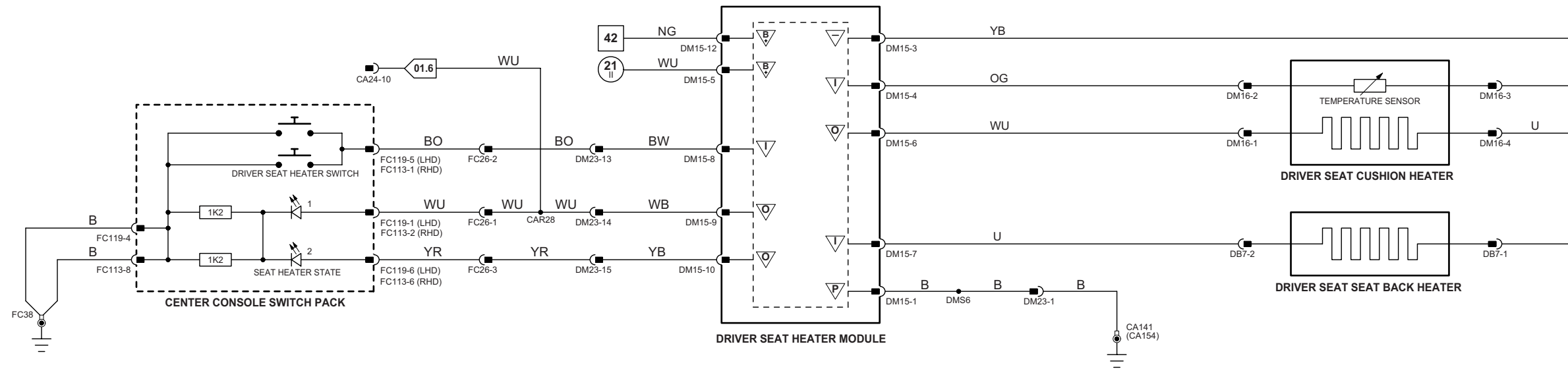

Driver Door Module

Pin	Description and Characteristic
I	CA85-2 LOCK / UNLOCK STATUS SWITCH (NORMALLY OPEN): OPEN CIRCUIT / GROUND
S	CA85-3 SCP +
S	CA85-4 SCP -
SG	CA85-7 SIGNAL GROUND: GROUND
PG	CA85-8 POWER GROUND: GROUND
PG	CA85-9 REMOTE KEYLESS ENTRY MODULE GROUND: GROUND
I	CA85-10 DOUBLE LOCK STATUS SWITCH (NORMALLY OPEN): OPEN CIRCUIT / GROUND
B+	CA85-11 BATTERY POWER SUPPLY: B+
B+	CA85-12 SWITCHED SYSTEM POWER SUPPLY: B+
O	DT2-6 REMOTE KEYLESS ENTRY MODULE POWER SUPPLY: B+
O	DT2-8 LOCK DRIVE: TO ACTIVATE, DDM SWITCHES CIRCUIT TO B+
O	DT2-9 UNLOCK DRIVE: TO ACTIVATE, DDM SWITCHES CIRCUIT TO B+
O	DT2-10 DOUBLE LOCK DRIVE: TO ACTIVATE, DDM SWITCHES CIRCUIT TO B+
D	DT2-13 REMOTE KEYLESS ENTRY MODULE SIGNAL: ENCODED COMMUNICATIONS
I	DT2-16 DRIVER DOOR ALARM SET / LOCK SWITCH (NORMALLY OPEN): OPEN CIRCUIT / GROUND
I	DT2-17 DRIVER DOOR ALARM RESET / UNLOCK SWITCH (NORMALLY OPEN): OPEN CIRCUIT / GROUND
D	DT2-18 REMOTE KEYLESS ENTRY MODULE SIGNAL: ENCODED COMMUNICATIONS

Front Electronic Module

Pin	Description and Characteristic
I	CA24-4 NON-VALET VEHICLES - EXTERNAL TRUNK RELEASE SWITCH (NORMALLY OPEN): OPEN CIRCUIT / GROUND
I	CA24-15 VALET VEHICLES - EXTERNAL TRUNK RELEASE SWITCH (NORMALLY OPEN) / VALET SWITCH (NORMALLY CLOSED): OPEN CIRCUIT / GROUND
I	CA24-16 PASSENGER DOOR AJAR SWITCH (NORMALLY OPEN): OPEN CIRCUIT / GROUND
I	CA31-8 DRIVER DOOR AJAR SWITCH (NORMALLY OPEN): OPEN CIRCUIT / GROUND
S	FH59-1 SCP -
B+	FH59-6 BATTERY POWER SUPPLY (LOGIC): B+
S	FH59-7 SCP +
B+	FH60-1 SWITCHED SYSTEM POWER SUPPLY: B+
PG	FH60-11 POWER GROUND: GROUND

Rear Electronic Module

Pin	Description and Characteristic
I	CA100-9 GLOBAL CLOSE SWITCH (NORMALLY OPEN): OPEN CIRCUIT / GROUND
B+	CA101-3 BATTERY POWER SUPPLY: B+
I	CA101-17 LHD - RH REAR DOOR AJAR SWITCH (NORMALLY OPEN): OPEN CIRCUIT / GROUND
I	CA101-18 RHD - LH REAR DOOR AJAR SWITCH (NORMALLY OPEN): OPEN CIRCUIT / GROUND
I	CA101-19 DOUBLE LOCK STATUS SWITCH (NORMALLY OPEN): OPEN CIRCUIT / GROUND
I	CA101-19 LOCK / UNLOCK STATUS SWITCH (NORMALLY OPEN): OPEN CIRCUIT / GROUND
S	CA102-1 SCP +
S	CA102-2 SCP -
PG	CA102-12 POWER GROUND: GROUND
I	CA102-14 TRUNK AJAR SWITCH (NORMALLY OPEN): OPEN CIRCUIT / GROUND
O	CA103-4 LOCK DRIVE: TO ACTIVATE, DDM SWITCHES CIRCUIT TO B+
O	CA103-5 LOCK DRIVE: TO ACTIVATE, DDM SWITCHES CIRCUIT TO B+
O	CA103-6 UNLOCK DRIVE: TO ACTIVATE, DDM SWITCHES CIRCUIT TO B+
O	CA103-7 UNLOCK DRIVE: TO ACTIVATE, DDM SWITCHES CIRCUIT TO B+
O	CA103-8 DOUBLE LOCK DRIVE: TO ACTIVATE, DDM SWITCHES CIRCUIT TO B+
O	CA103-9 DOUBLE LOCK DRIVE: TO ACTIVATE, DDM SWITCHES CIRCUIT TO B+
O	CA103-10 TRUNK RELEASE DRIVE: TO ACTIVATE, DDM SWITCHES CIRCUIT TO B+
B+	CA103-13 SWITCHED SYSTEM POWER SUPPLY: B+
I	CA103-16 LHD - LH REAR DOOR AJAR SWITCH (NORMALLY OPEN): OPEN CIRCUIT / GROUND
I	CA103-16 RHD - RH REAR DOOR AJAR SWITCH (NORMALLY OPEN): OPEN CIRCUIT / GROUND

The following abbreviations are used to represent values for Control Module Pin-Out data

I	Input	PG	Power Ground	C	CAN Network	D	Serial and Encoded Data
O	Output	SS	Sensor / Signal Supply V	S	SCP Network	V	Voltage (DC)
B+	Battery Voltage	SG	Sensor / Signal Ground	D2	D2B Network	PWM	Pulse Width Modulated

CAUTION: The information on this data page is furnished to aid the user in understanding circuit operation. THIS INFORMATION SHOULD BE USED FOR REFERENCE ONLY.

NOTE: The values listed are approximately those that can be expected at the control module connector pins with all circuit connections made and all components connected and fitted.

Fig. 12.1

COMPONENTS

Component	Connector(s)	Connector Description	Location
CENTER CONSOLE SWITCH PACK	FC113	8-WAY / BLACK	CENTER CONSOLE
	FC119	8-WAY / BLACK	
DOOR LATCH ASSEMBLY - DRIVER	DT5	10-WAY / BLACK	DRIVER DOOR
DOOR LATCH ASSEMBLY - LH REAR	CA81	10-WAY / BLACK	LH REAR DOOR
DOOR LATCH ASSEMBLY - PASSENGER	PT3	10-WAY / BLACK	PASSENGER DOOR
DOOR LATCH ASSEMBLY - RH REAR	CA90	10-WAY / BLACK	RH REAR DOOR
DRIVER DOOR MODULE	CA85	12-WAY / BLACK	DRIVER DOOR
	DD4	26-WAY / NATURAL	
	DT2	20-WAY / BLACK	
EXTERNAL TRUNK RELEASE SWITCH	CA97	2-WAY / BLACK	LUGGAGE COMPARTMENT LID
FRONT ELECTRONIC MODULE	CA24	26-WAY / NATURAL	LH 'A' POST
	CA31	20-WAY / BLACK	
	FH9	22-WAY / BLACK	
	FH59	12-WAY / BLACK	
	FH60	17-WAY / BLACK	
FUEL FLAP AND TRUNK RELEASE SWITCH PACK	FC43	10-WAY / GREY	INSTRUMENT PANEL
FUEL FLAP RELAY	-	-	REAR POWER DISTRIBUTION FUSE BOX - R8
FUEL FLAP RELEASE SOLENOID	CA7	2-WAY / BLACK	LUGGAGE COMPARTMENT, RH SIDE, FRONT
REAR ELECTRONIC MODULE	CA63	17-WAY / BLACK	LUGGAGE COMPARTMENT, RH REAR
	CA100	12-WAY / BLACK	
	CA101	20-WAY / BLACK	
	CA102	22-WAY / BLACK	
	CA103	26-WAY / NATURAL	
REAR POWER DISTRIBUTION FUSE BOX	-	-	LUGGAGE COMPARTMENT
REMOTE KEYLESS ENTRY MODULE	CA303	4-WAY / BLACK	UNDER CENTER CONSOLE
TRUNK AJAR SWITCH	CA26	4-WAY / BLACK	LUGGAGE COMPARTMENT LID
TRUNK RELEASE SOLENOID	CA26	4-WAY / BLACK	LUGGAGE COMPARTMENT LID
VALET SWITCH	VS1	6-WAY / BLACK	GLOVE BOX

HARNESS IN-LINE CONNECTORS

Connector	Connector Description / Location	Location
DT8	14-WAY / GREY / CABIN HARNESS TO DRIVER DOOR TRIM HARNESS	DRIVER DOOR
DT10	10-WAY / GREY / CABIN HARNESS TO DRIVER DOOR TRIM HARNESS	DRIVER DOOR
FC23	10-WAY / GREY / CABIN HARNESS TO FASCIA HARNESS	BEHIND INSTRUMENT PANEL, LH SIDE
FC33	16-WAY / GREEN / CABIN HARNESS TO FASCIA HARNESS	BEHIND INSTRUMENT PANEL, RH SIDE
FC39	10-WAY / GREY / CABIN HARNESS TO FASCIA HARNESS	BEHIND INSTRUMENT PANEL, RH SIDE
FC121	4-WAY / GREY / FASCIA HARNESS IN-LINE CONNECTOR	BEHIND GLOVE BOX
PT1	14-WAY / GREY / CABIN HARNESS TO PASSENGER DOOR TRIM HARNESS	PASSENGER DOOR

GROUNDS

Ground	Location
CA30	LH LOWER 'A' POST, ADJACENT TO THE FRONT ELECTRONIC MODULE (REARWARD OF FH77)
CA50	RH LOWER 'A' POST, BELOW PRIMARY JUNCTION FUSE BOX
CA141	UNDER LH FRONT SEAT
CA154	UNDER RH FRONT SEAT
CA156	LUGGAGE COMPARTMENT, RH SIDE
FC38	UNDER CENTER OF INSTRUMENT PANEL, ON TRANSMISSION TUNNEL
FH77	LH LOWER 'A' POST, ADJACENT TO THE FRONT ELECTRONIC MODULE (FORWARD OF CA30)

FOR CONTROL MODULE PIN-OUT INFORMATION, UNFOLD PAGE TO LEFT.

Refer to the front of this book for detailed information and illustrations regarding the location and identification of harnesses, relays, fuses, grounds, control modules and control module pins.

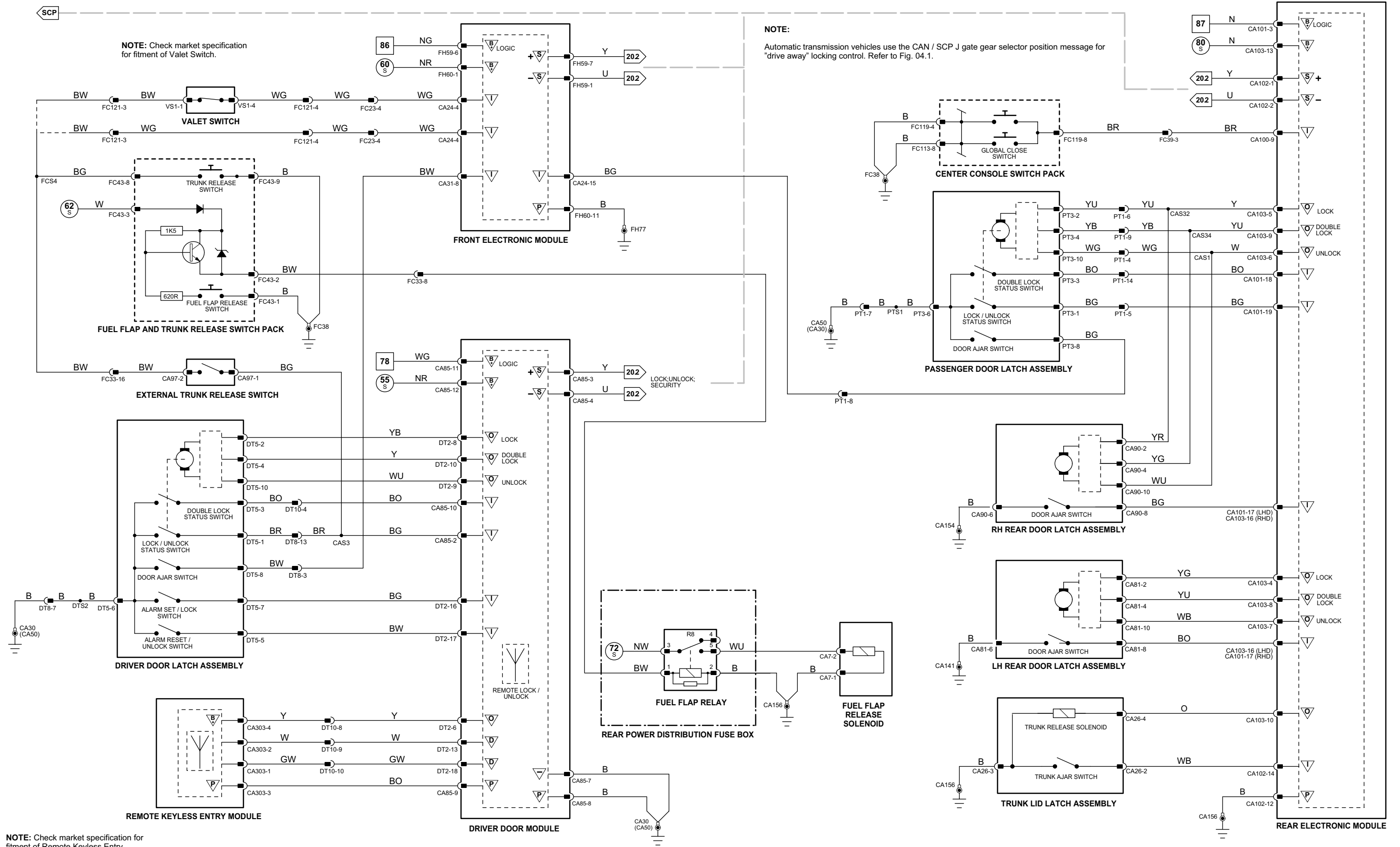

NOTE: Check market specification for fitment of Remote Keyless Entry.

1 → 3	4 → 76	77 → 92	1 → 14	15 → 45	46 → 80	81 → 118	Input	Battery Voltage	Sensor/Signal Supply V	CAN	D2B Network
Fig. 01.1	Fig. 01.2	Fig. 01.3	Fig. 01.4	Fig. 01.5	Fig. 01.8	Fig. 01.7	Output	Power Ground	Sensor/Signal Ground	SCP	Serial and Encoded Data

VARIANT: Double Locking Vehicles
 VIN RANGE: All
 DATE OF ISSUE: April 2006

Driver Door Module

	Pin	Description and Characteristic
I	CA85-2	LOCK / UNLOCK STATUS SWITCH (NORMALLY OPEN): OPEN CIRCUIT / GROUND
S	CA85-3	SCP +
S	CA85-4	SCP -
SG	CA85-7	SIGNAL GROUND: GROUND
PG	CA85-8	POWER GROUND: GROUND
B+	CA85-11	BATTERY POWER SUPPLY: B+
B+	CA85-12	SWITCHED SYSTEM POWER SUPPLY: B+
O	DT2-8	LOCK DRIVE: TO ACTIVATE, DDM SWITCHES CIRCUIT TO B+
O	DT2-9	UNLOCK DRIVE: TO ACTIVATE, DDM SWITCHES CIRCUIT TO B+
I	DT2-16	DRIVER DOOR ALARM SET / LOCK SWITCH (NORMALLY OPEN): OPEN CIRCUIT / GROUND
I	DT2-17	DRIVER DOOR ALARM RESET / UNLOCK SWITCH (NORMALLY OPEN): OPEN CIRCUIT / GROUND

Front Electronic Module

	Pin	Description and Characteristic
I	CA24-4	EXTERNAL TRUNK RELEASE SWITCH (NORMALLY OPEN) / VALET SWITCH (NORMALLY CLOSED): OPEN CIRCUIT / GROUND
I	CA24-15	PASSENGER DOOR AJAR SWITCH (NORMALLY OPEN): OPEN CIRCUIT / GROUND
I	CA31-8	DRIVER DOOR AJAR SWITCH (NORMALLY OPEN): OPEN CIRCUIT / GROUND
S	FH59-1	SCP -
B+	FH59-6	BATTERY POWER SUPPLY (LOGIC): B+
S	FH59-7	SCP +
B+	FH60-1	SWITCHED SYSTEM POWER SUPPLY: B+
PG	FH60-11	POWER GROUND: GROUND

Rear Electronic Module

	Pin	Description and Characteristic
I	CA100-9	GLOBAL CLOSE SWITCH (NORMALLY OPEN): OPEN CIRCUIT / GROUND
B+	CA101-3	BATTERY POWER SUPPLY: B+
I	CA101-17	LHD - RH REAR DOOR AJAR SWITCH (NORMALLY OPEN): OPEN CIRCUIT / GROUND RHD - LH REAR DOOR AJAR SWITCH (NORMALLY OPEN): OPEN CIRCUIT / GROUND
I	CA101-19	LOCK / UNLOCK STATUS SWITCH (NORMALLY OPEN): OPEN CIRCUIT / GROUND
S	CA102-1	SCP +
S	CA102-2	SCP -
PG	CA102-12	POWER GROUND: GROUND
I	CA102-14	TRUNK AJAR SWITCH (NORMALLY OPEN): OPEN CIRCUIT / GROUND
O	CA103-4	LOCK DRIVE: TO ACTIVATE, DDM SWITCHES CIRCUIT TO B+
O	CA103-5	LOCK DRIVE: TO ACTIVATE, DDM SWITCHES CIRCUIT TO B+
O	CA103-6	UNLOCK DRIVE: TO ACTIVATE, DDM SWITCHES CIRCUIT TO B+
O	CA103-7	UNLOCK DRIVE: TO ACTIVATE, DDM SWITCHES CIRCUIT TO B+
O	CA103-10	TRUNK RELEASE DRIVE: TO ACTIVATE, DDM SWITCHES CIRCUIT TO B+
B+	CA103-13	SWITCHED SYSTEM POWER SUPPLY: B+
I	CA103-16	LHD - LH REAR DOOR AJAR SWITCH (NORMALLY OPEN): OPEN CIRCUIT / GROUND RHD - RH REAR DOOR AJAR SWITCH (NORMALLY OPEN): OPEN CIRCUIT / GROUND

The following abbreviations are used to represent values for Control Module Pin-Out data

I	Input	PG	Power Ground	C	CAN Network	D	Serial and Encoded Data
O	Output	SS	Sensor / Signal Supply V	S	SCP Network	V	Voltage (DC)
B+	Battery Voltage	SG	Sensor / Signal Ground	D2	D2B Network	PWM	Pulse Width Modulated

CAUTION: The information on this data page is furnished to aid the user in understanding circuit operation. THIS INFORMATION SHOULD BE USED FOR REFERENCE ONLY.

NOTE: The values listed are approximately those that can be expected at the control module connector pins with all circuit connections made and all components connected and fitted.

Fig. 12.2

COMPONENTS

Component	Connector(s)	Connector Description	Location
CENTER CONSOLE SWITCH PACK	FC113	8-WAY / BLACK	CENTER CONSOLE
	FC119	8-WAY / BLACK	
DOOR LATCH ASSEMBLY - DRIVER	DT5	10-WAY / BLACK	DRIVER DOOR
DOOR LATCH ASSEMBLY - LH REAR	CA81	10-WAY / BLACK	LH REAR DOOR
DOOR LATCH ASSEMBLY - PASSENGER	PT3	10-WAY / BLACK	PASSENGER DOOR
DOOR LATCH ASSEMBLY - RH REAR	CA90	10-WAY / BLACK	RH REAR DOOR
DRIVER DOOR MODULE	CA85	12-WAY / BLACK	DRIVER DOOR
	DD4	26-WAY / NATURAL	
	DT2	20-WAY / BLACK	
EXTERNAL TRUNK RELEASE SWITCH	CA97	2-WAY / BLACK	LUGGAGE COMPARTMENT LID
FRONT ELECTRONIC MODULE	CA24	26-WAY / NATURAL	LH 'A' POST
	CA31	20-WAY / BLACK	
	FH9	22-WAY / BLACK	
	FH59	12-WAY / BLACK	
	FH60	17-WAY / BLACK	
FUEL FLAP AND TRUNK RELEASE SWITCH PACK	FC43	10-WAY / GREY	INSTRUMENT PANEL
FUEL FLAP RELAY	—	—	REAR POWER DISTRIBUTION FUSE BOX - R8
FUEL FLAP RELEASE SOLENOID	CA106	2-WAY / GREY	LUGGAGE COMPARTMENT, RH SIDE, FRONT
REAR ELECTRONIC MODULE	CA63	17-WAY / BLACK	LUGGAGE COMPARTMENT, RH REAR
	CA100	12-WAY / BLACK	
	CA101	20-WAY / BLACK	
	CA102	22-WAY / BLACK	
	CA103	26-WAY / NATURAL	
REAR POWER DISTRIBUTION FUSE BOX	—	—	LUGGAGE COMPARTMENT
TRUNK LID LATCH ASSEMBLY	CA26	4-WAY / BLACK	LUGGAGE COMPARTMENT LID
VALET SWITCH	VS1	6-WAY / BLACK	GLOVE BOX

HARNESS IN-LINE CONNECTORS

Connector	Connector Description / Location	Location
DT8	14-WAY / GREY / CABIN HARNESS TO DRIVER DOOR TRIM HARNESS	DRIVER DOOR
FC23	10-WAY / GREY / CABIN HARNESS TO FASCIA HARNESS	BEHIND INSTRUMENT PANEL, LH SIDE
FC33	16-WAY / GREEN / CABIN HARNESS TO FASCIA HARNESS	BEHIND INSTRUMENT PANEL, RH SIDE
FC39	10-WAY / GREY / CABIN HARNESS TO FASCIA HARNESS	BEHIND INSTRUMENT PANEL, RH SIDE
FC121	4-WAY / GREY / FASCIA HARNESS IN-LINE CONNECTOR	BEHIND GLOVE BOX
PT1	14-WAY / GREY / CABIN HARNESS TO PASSENGER DOOR TRIM HARNESS	PASSENGER DOOR

GROUNDS

Ground	Location
CA30	LH LOWER 'A' POST, ADJACENT TO THE FRONT ELECTRONIC MODULE (REARWARD OF FH77)
CA50	RH LOWER 'A' POST, BELOW PRIMARY JUNCTION FUSE BOX
CA141	UNDER LH FRONT SEAT
CA154	UNDER RH FRONT SEAT
CA156	LUGGAGE COMPARTMENT, RH SIDE
FC38	UNDER CENTER OF INSTRUMENT PANEL, ON TRANSMISSION TUNNEL
FH77	LH LOWER 'A' POST, ADJACENT TO THE FRONT ELECTRONIC MODULE (FORWARD OF CA30)

FOR CONTROL MODULE PIN-OUT INFORMATION, UNFOLD PAGE TO LEFT.

Refer to the front of this book for detailed information and illustrations regarding the location and identification of harnesses, relays, fuses, grounds, control modules and control module pins.

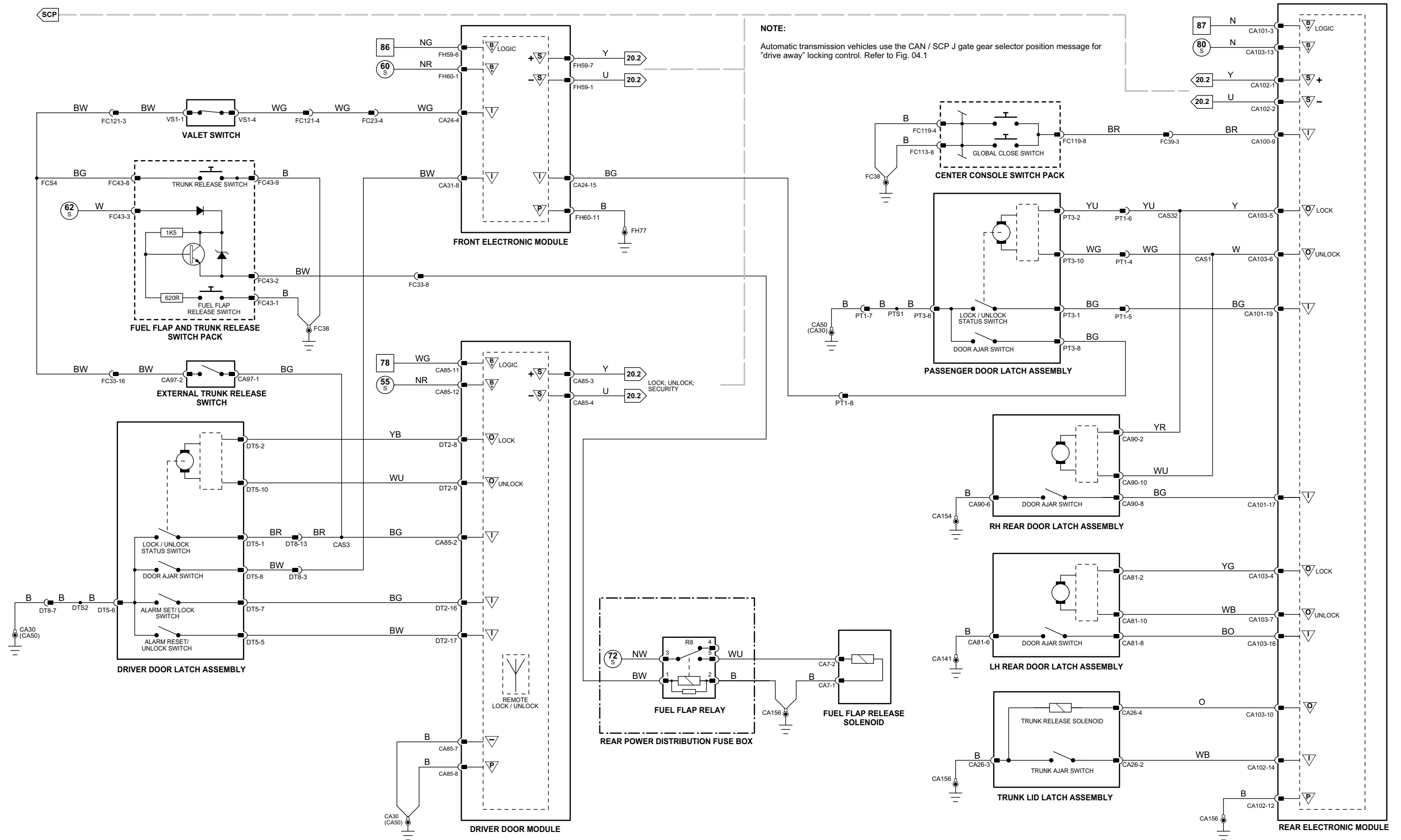

1 → 3	4 → 76	77 → 92	1 → 14	15 → 45	46 → 80	81 → 118	Input	Battery Voltage	Sensor/Signal Supply V	CAN	D2B Network
Fig. 01.1	Fig. 01.2	Fig. 01.3	Fig. 01.4	Fig. 01.5	Fig. 01.6	Fig. 01.7	Output	Power Ground	Sensor/Signal Ground	SCP	Serial and Encoded Data

VARIANT: Non Double Locking Vehicles
VIN RANGE: All
DATE OF ISSUE: April 2006

Audio Unit

Pin	Description and Characteristic
O FC94-8	SECURITY SYSTEM GROUND SENSING: GROUND WHEN AUDIO UNIT INSTALLED

Driver Door Module

Pin	Description and Characteristic
I CA85-2	LOCK / UNLOCK STATUS SWITCH (NORMALLY OPEN): OPEN CIRCUIT / GROUND
S CA85-3	SCP +
S CA85-4	SCP -
PG CA85-8	POWER GROUND: GROUND
PG CA85-9	REMOTE KEYLESS ENTRY MODULE GROUND: GROUND
I CA85-10	DOUBLE LOCK STATUS SWITCH (NORMALLY OPEN): OPEN CIRCUIT / GROUND
B+ CA85-11	BATTERY POWER SUPPLY: B+
B+ CA85-12	SWITCHED SYSTEM POWER SUPPLY: B+
O DT2-6	REMOTE KEYLESS ENTRY MODULE POWER SUPPLY: B+
O DT2-8	LOCK DRIVE: TO ACTIVATE, DDM SWITCHES CIRCUIT TO B+
O DT2-9	UNLOCK DRIVE: TO ACTIVATE, DDM SWITCHES CIRCUIT TO B+
O DT2-10	DOUBLE LOCK DRIVE: TO ACTIVATE, DDM SWITCHES CIRCUIT TO B+
D DT2-13	REMOTE KEYLESS ENTRY MODULE SIGNAL: ENCODED COMMUNICATIONS
I DT2-16	DRIVER DOOR ALARM SET / LOCK SWITCH (NORMALLY OPEN): OPEN CIRCUIT / GROUND
I DT2-17	DRIVER DOOR ALARM RESET / UNLOCK SWITCH (NORMALLY OPEN): OPEN CIRCUIT / GROUND
D DT2-18	REMOTE KEYLESS ENTRY MODULE SIGNAL: ENCODED COMMUNICATIONS

Front Electronic Module

Pin	Description and Characteristic
I CA24-15	PASSENGER DOOR AJAR SWITCH (NORMALLY OPEN): OPEN CIRCUIT / GROUND
I CA31-3	IGNITION SWITCHED VOLTAGE SIGNAL (II): B+
I CA31-5	REM SECURITY GROUND SENSE: OPEN CIRCUIT IF REM REMOVED
I CA31-7	AUDIO UNIT SECURITY GROUND SENSE: OPEN CIRCUIT IF AUDIO UNIT REMOVED
I CA31-8	DRIVER DOOR AJAR SWITCH (NORMALLY OPEN): OPEN CIRCUIT / GROUND
I CA31-18	INTRUSION AND INCLINATION SENSORS SIGNAL: GROUND (PULSED)
O FH9-16	INTRUSION AND INCLINATION SENSORS SUPPLY VOLTAGE: B+
S FH59-1	SCP -
I FH59-3	HOOD AJAR SWITCH (NORMALLY OPEN): OPEN CIRCUIT / GROUND
B+ FH59-6	BATTERY POWER SUPPLY (LOGIC): B+
S FH59-7	SCP +
O FH59-8	HORN RELAY ACTIVATE: TO ACTIVATE, FEM SWITCHES CIRCUIT TO GROUND
B+ FH60-1	SWITCHED SYSTEM POWER SUPPLY: B+
O FH60-3	ACTIVE SECURITY SOUNDER ACTIVATE: ENCODED COMMUNICATION
O FH60-4	RH FRONT TURN SIGNAL ACTIVATE: TO ACTIVATE, FEM SWITCHES CIRCUIT TO GROUND (PULSED)
O FH60-5	LH FRONT TURN SIGNAL ACTIVATE: TO ACTIVATE, FEM SWITCHES CIRCUIT TO GROUND (PULSED)
PG FH60-6	STEERING COLUMN LOCK CONTROL MODULE POWER GROUND SUPPLY: GROUND
PG FH60-11	POWER GROUND: GROUND
O FH60-16	PASSIVE SECURITY SOUNDER ACTIVATE: TO ACTIVATE, FEM SWITCHES CIRCUIT TO B+

Instrument Cluster

Pin	Description and Characteristic
O FC8-1	SECURITY INDICATOR DRIVE: ACTIVE = PULSED GROUND
PG FC8-2	POWER GROUND: GROUND
I FC8-5	KEY-IN AUDIBLE WARNING: B+ WHEN KEY IN
B+ FC8-14	IGNITION SWITCHED POWER SUPPLY (II): B+
B+ FC8-15	BATTERY POWER SUPPLY (LOGIC): B+
SG FC8-32	SIGNAL GROUND: GROUND
D FC9-16	PATS TRANSCEIVER: ENCODED COMMUNICATION
S FC9-25	SCP +
S FC9-26	SCP -
C FC9-28	CAN +
C FC9-29	CAN -
I FC9-31	PATS GROUND: GROUND
D FC9-32	PATS TRANSCEIVER: ENCODED COMMUNICATION

Rear Electronic Module

Pin	Description and Characteristic
O CA63-3	LH REAR TURN SIGNAL ACTIVATE: TO ACTIVATE, REM SWITCHES CIRCUIT TO GROUND (PULSED)
O CA63-4	RH REAR TURN SIGNAL ACTIVATE: TO ACTIVATE, REM SWITCHES CIRCUIT TO GROUND (PULSED)
O CA100-1	STEERING COLUMN LOCK CONTROL MODULE SUPPLY VOLTAGE: B+
B+ CA101-3	BATTERY POWER SUPPLY: B+
O CA101-5	REM SECURITY GROUND SENSE: OPEN CIRCUIT IF REM REMOVED
I CA101-17	LHD - RH REAR DOOR AJAR SWITCH (NORMALLY OPEN): OPEN CIRCUIT / GROUND RHD - LH REAR DOOR AJAR SWITCH (NORMALLY OPEN): OPEN CIRCUIT / GROUND
S CA102-1	SCP +
S CA102-2	SCP -
PG CA102-12	POWER GROUND: GROUND
I CA102-14	TRUNK AJAR SWITCH (NORMALLY OPEN): OPEN CIRCUIT / GROUND
B+ CA103-13	SWITCHED SYSTEM POWER SUPPLY: B+
I CA103-16	LHD - LH REAR DOOR AJAR SWITCH (NORMALLY OPEN): OPEN CIRCUIT / GROUND RHD - RH REAR DOOR AJAR SWITCH (NORMALLY OPEN): OPEN CIRCUIT / GROUND

The following abbreviations are used to represent values for Control Module Pin-Out data

I	Input	PG	Power Ground	C	CAN Network	D	Serial and Encoded Data
O	Output	SS	Sensor / Signal Supply V	S	SCP Network	V	Voltage (DC)
B+	Battery Voltage	SG	Sensor / Signal Ground	D2	D2B Network	PWM	Pulse Width Modulated

CAUTION: The information on this data page is furnished to aid the user in understanding circuit operation. THIS INFORMATION SHOULD BE USED FOR REFERENCE ONLY.

NOTE: The values listed are approximately those that can be expected at the control module connector pins with all circuit connections made and all components connected and fitted.

Fig. 12.3

COMPONENTS

Component	Connector(s)	Connector Description	Location
ACTIVE SECURITY SOUNDER	AT4	3-WAY / BLACK	ENGINE COMPARTMENT, REARWARD OF RH HEADLAMP UNIT
AUDIO UNIT	FC94	20-WAY / BLACK	CENTER CONSOLE
	FC96	ANTENNA CONNECTOR	
	FC108	FIBER OPTIC CONNECTOR	
DOOR LATCH ASSEMBLY - DRIVER	DT5	10-WAY / BLACK	DRIVER DOOR
DOOR LATCH ASSEMBLY - LH REAR	CA81	10-WAY / BLACK	LH REAR DOOR
DOOR LATCH ASSEMBLY - PASSENGER	PT3	10-WAY / BLACK	PASSENGER DOOR
DOOR LATCH ASSEMBLY - RH REAR	CA90	10-WAY / BLACK	RH REAR DOOR
DRIVER DOOR MODULE	CA85	12-WAY / BLACK	DRIVER DOOR
	DD4	26-WAY / NATURAL	
	DT2	20-WAY / BLACK	
FRONT ELECTRONIC MODULE	CA24	26-WAY / NATURAL	LH 'A' POST
	CA31	20-WAY / BLACK	
	FH9	22-WAY / BLACK	
	FH59	12-WAY / BLACK	
	FH60	17-WAY / BLACK	
FRONT POWER DISTRIBUTION FUSE BOX	—	—	ENGINE COMPARTMENT, RH SIDE
HOOD AJAR SWITCH	FH21	2-WAY / BLACK	ENGINE COMPARTMENT, ADJACENT TO RH SUSPENSION TURRET
HORN RELAY	—	—	FRONT POWER DISTRIBUTION FUSE BOX - R12
HORNS	FH29	2-WAY / BLACK	FORWARD OF RADIATOR
IGNITION SWITCH	FC18	7-WAY / BLACK	STEERING COLUMN COWLING
INCLINATION SENSOR	CA173	4-WAY / GREY	LUGGAGE COMPARTMENT, LH REAR
INSTRUMENT CLUSTER	FC8	32-WAY / BLACK	INSTRUMENT PANEL
	FC9	32-WAY / BLACK	
PASSIVE ANTI-THEFT SYSTEM TRANSCEIVER	FC52	4-WAY / GREEN	STEERING COLUMN, IGNITION SWITCH
PASSIVE SECURITY SOUNDER	AT2	1-WAY / BLACK	ENGINE COMPARTMENT, REARWARD OF RH HEADLAMP UNIT
	AT3	1-WAY / BLACK	
REAR ELECTRONIC MODULE	CA63	17-WAY / BLACK	LUGGAGE COMPARTMENT, RH REAR
	CA100	12-WAY / BLACK	
	CA101	20-WAY / BLACK	
	CA102	22-WAY / BLACK	
	CA103	26-WAY / NATURAL	
REMOTE KEYLESS ENTRY MODULE	CA303	4-WAY / BLACK	UNDER CENTER CONSOLE
ROOF CONSOLE	CA250	22-WAY / BLACK	ROOF HEADLINER
SECURITY INDICATOR	SL1	6-WAY / BLACK	INSTRUMENT PANEL GLARE SHIELD, FRONT CENTER
STEERING COLUMN LOCK MODULE	FC59	4-WAY / BLACK	ADJACENT TO STEERING COLUMN LOCK
TRUNK LID LATCH ASSEMBLY	CA26	4-WAY / BLACK	LUGGAGE COMPARTMENT LID

HARNESS IN-LINE CONNECTORS

Connector	Connector Description / Location	Location
DT8	14-WAY / GREY / CABIN HARNESS TO DRIVER DOOR TRIM HARNESS	DRIVER DOOR
DT10	10-WAY / GREY / CABIN HARNESS TO DRIVER DOOR TRIM HARNESS	DRIVER DOOR
FC4	14-WAY / GREEN / FASCIA HARNESS IN-LINE CONNECTOR	BEHIND INSTRUMENT PANEL, LH SIDE
FC23	10-WAY / GREY / CABIN HARNESS TO FASCIA HARNESS	BEHIND INSTRUMENT PANEL, LH SIDE
FC39	10-WAY / GREY / CABIN HARNESS TO FASCIA HARNESS	BEHIND INSTRUMENT PANEL, RH SIDE
FH6	16-WAY GREEN / CABIN HARNESS TO FRONT HARNESS	LH 'A' POST, ADJACENT TO FEM
FH89	4-WAY / GREY / FRONT HARNESS TO ALARM LINK	ADJACENT TO FRONT POWER DISTRIBUTION FUSE BOX
PT1	14-WAY / GREY / CABIN HARNESS TO PASSENGER DOOR TRIM HARNESS	PASSENGER DOOR
SL3	10-WAY / GREY / FASCIA HARNESS TO SOLAR SENSOR LINK	BEHIND INSTRUMENT PANEL, RH SIDE

GROUND S

Ground	Location
CA30	LH LOWER 'A' POST, ADJACENT TO THE FRONT ELECTRONIC MODULE (REARWARD OF FH77)
CA50	RH LOWER 'A' POST, BELOW PRIMARY JUNCTION FUSE BOX
CA141	UNDER LH FRONT SEAT
CA154	UNDER RH FRONT SEAT
CA156	LUGGAGE COMPARTMENT, RH SIDE
CA158	LUGGAGE COMPARTMENT, LH SIDE REAR CORNER
FC38	UNDER CENTER OF INSTRUMENT PANEL, ON TRANSMISSION TUNNEL
FH22	ENGINE COMPARTMENT, BEHIND LH HEADLAMP
FH42	ENGINE COMPARTMENT, BEHIND RH HEADLAMP
FH77	LH LOWER 'A' POST, ADJACENT TO THE FRONT ELECTRONIC MODULE (FORWARD OF CA30)

FOR CONTROL MODULE PIN-OUT INFORMATION, UNFOLD PAGE TO LEFT.

Refer to the front of this book for detailed information and illustrations regarding the location and identification of harnesses, relays, fuses, grounds, control modules and control module pins.

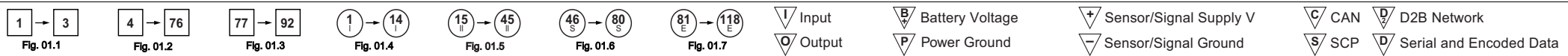
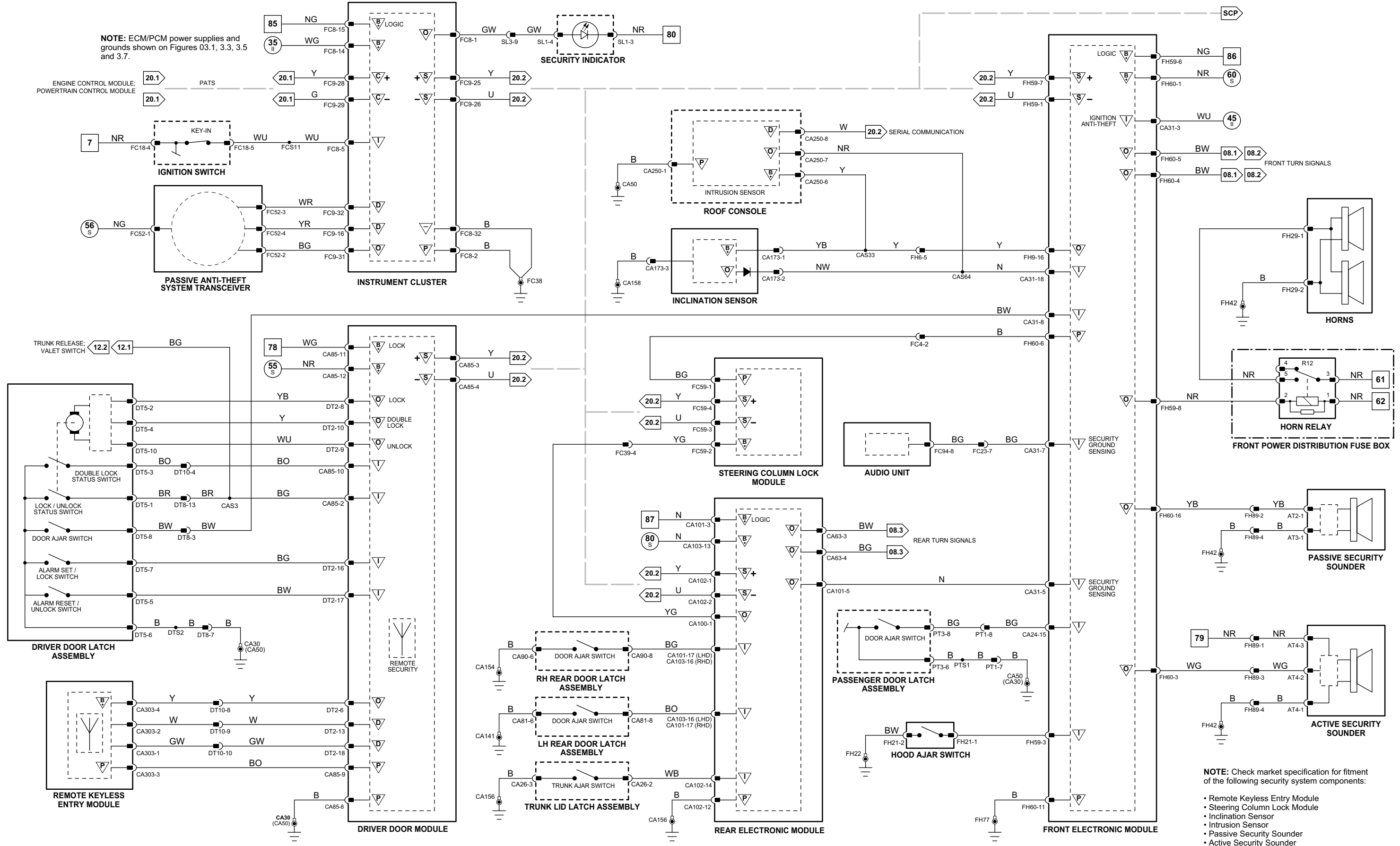

VARIANT: All Vehicles
VIN RANGE: All
DATE OF ISSUE: April 2006

Front Electronic Module

	Pin	Description and Characteristic
I	CA31-2	WIPER MODE SELECT: VARIABLE RESISTANCE
I	CA31-13	WIPER DELAY / WASH: VARIABLE RESISTANCE
SG	CA31-14	WIPE / WASH SWITCH SIGNAL GROUND: GROUND
O	FH9-1	WIPER PARK RELAY ACTIVATE: TO ACTIVATE, FEM SWITCHES CIRCUIT TO GROUND
O	FH9-3	WIPER HIGH / LOW RELAY ACTIVATE: TO ACTIVATE, FEM SWITCHES CIRCUIT TO GROUND
I	FH9-13	WIPER PARK: PARK = GROUND
O	FH9-14	WINDSHIELD WASHER PUMP DRIVE: TO ACTIVATE, FEM SWITCHES CIRCUIT TO B+
I	FH9-15	WASHER FLUID LEVEL SWITCH (NORMALLY OPEN): OPEN CIRCUIT / GROUND
S	FH59-1	SCP -
O	FH59-4	POWER WASH RELAY ACTIVATE: TO ACTIVATE, FEM SWITCHES CIRCUIT TO GROUND
S	FH59-7	SCP +
B+	FH60-1	SWITCHED SYSTEM POWER SUPPLY: B+
PG	FH60-11	POWER GROUND: GROUND

Fig. 13.1

COMPONENTS

Component	Connector(s)	Connector Description	Location
FRONT ELECTRONIC MODULE	CA24	26-WAY / NATURAL	LH 'A' POST
	CA31	20-WAY / BLACK	
	FH9	22-WAY / BLACK	
	FH59	12-WAY / BLACK	
	FH60	17-WAY / BLACK	
FRONT POWER DISTRIBUTION FUSE BOX	—	—	ENGINE COMPARTMENT, RH SIDE
POWER WASH PUMP	FH38	2-WAY / BLACK	ENGINE COMPARTMENT, WASHER FLUID TANK
POWER WASH RELAY	—	—	FRONT POWER DISTRIBUTION FUSE BOX - R18
RAIN SENSING MODULE	CA248	12-WAY / BLACK	LUGGAGE COMPARTMENT, UNDER PARCEL SHELF
RAIN SENSING UNIT	RF14	3-WAY / BLACK	REAR VIEW MIRROR
WASHER FLUID LEVEL SWITCH	FH37	2-WAY / BLACK	WASHER FLUID CONTAINER
WINDSHIELD WASHER PUMP	FH36	5-WAY / GREEN	ENGINE COMPARTMENT, ADJACENT TO WASHER FLUID CONTAINER
WIPE / WASH SWITCH	FC118	6-WAY / BLACK	STEERING COLUMN STALK
WIPER HIGH / LOW RELAY	—	—	FRONT POWER DISTRIBUTION FUSE BOX - R15
WIPER MOTOR ASSEMBLY	FH17	6-WAY / BLACK	ENGINE COMPARTMENT, BULKHEAD
WIPER PARK RELAY	—	—	FRONT POWER DISTRIBUTION FUSE BOX - R16

HARNES IN-LINE CONNECTORS

Connector	Connector Description / Location	Location
FC19	16-WAY / GREEN / CABIN HARNESS TO FASCIA HARNESS	BEHIND INSTRUMENT PANEL, LH SIDE
FH1	22-WAY / DARK GREY / CABIN HARNESS TO FRONT HARNESS	RH 'A' POST, LOWER
RF34	16-WAY / GREEN / CABIN HARNESS TO DOOR HARNESS	'D' POST, UNDER PARCEL SHELF

GROUNDS

Ground	Location
CA116	BEHIND REAR SEAT BACK, RH SIDE
FH22	ENGINE COMPARTMENT, BEHIND LH HEADLAMP
FH42	ENGINE COMPARTMENT, BEHIND RH HEADLAMP
FH77	LH LOWER 'A' POST, ADJACENT TO THE FRONT ELECTRONIC MODULE (FORWARD OF CA30)

FOR CONTROL MODULE PIN-OUT INFORMATION, UNFOLD PAGE TO LEFT.

The following abbreviations are used to represent values for Control Module Pin-Out data

I	Input	PG	Power Ground	C	CAN Network	D	Serial and Encoded Data
O	Output	SS	Sensor / Signal Supply V	S	SCP Network	V	Voltage (DC)
B+	Battery Voltage	SG	Sensor / Signal Ground	D2	D2B Network	PWM	Pulse Width Modulated

CAUTION: The information on this data page is furnished to aid the user in understanding circuit operation. THIS INFORMATION SHOULD BE USED FOR REFERENCE ONLY.

NOTE: The values listed are approximately those that can be expected at the control module connector pins with all circuit connections made and all components connected and fitted.

Refer to the front of this book for detailed information and illustrations regarding the location and identification of harnesses, relays, fuses, grounds, control modules and control module pins.

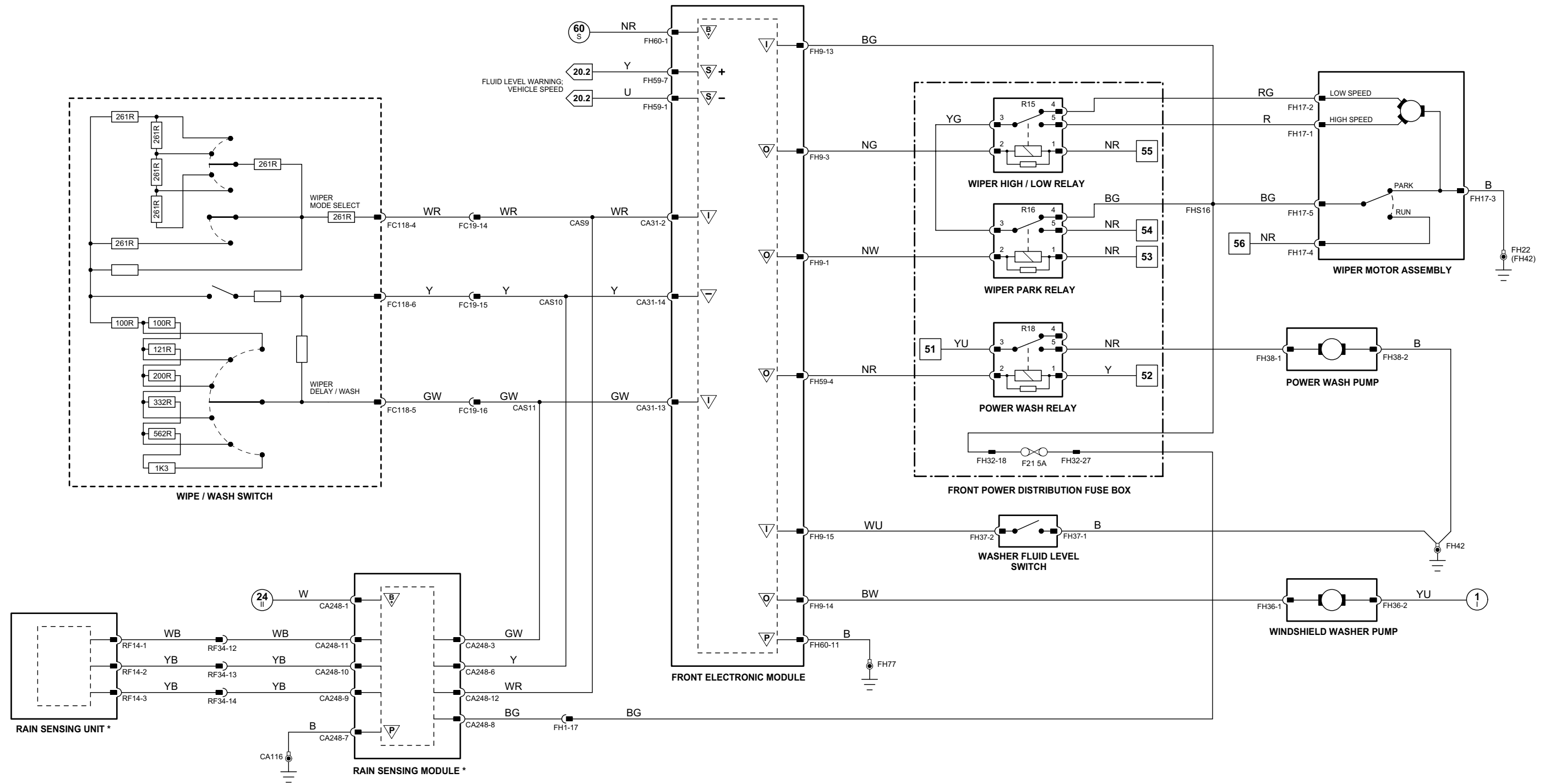

* NOTE: Rain sensing system – rain sensing vehicles only.



VARIANT: All Vehicles
 VIN RANGE: All
 DATE OF ISSUE: April 2006

Driver Door Module

	Pin	Description and Characteristic
S	CA85-3	SCP +
S	CA85-4	SCP -
PG	CA85-8	POWER GROUND: GROUND
B+	CA85-11	BATTERY POWER SUPPLY: B+
B+	CA85-12	SWITCHED SYSTEM POWER SUPPLY: B+
O	DD4-1	POWER WINDOWS ENABLE: TO ACTIVATE, DDM SWITCHES CIRCUIT TO B+
O	DD4-26	GLOBAL CLOSE SIGNAL: 20 ms PULSED SIGNAL
I	DT2-16	DRIVER DOOR ALARM SET / LOCK SWITCH (NORMALLY OPEN): OPEN CIRCUIT / GROUND
I	DT2-17	DRIVER DOOR ALARM RESET / UNLOCK SWITCH (NORMALLY OPEN): OPEN CIRCUIT / GROUND

Rear Electronic Module

	Pin	Description and Characteristic
I	CA100-9	GLOBAL CLOSE SWITCH (NORMALLY OPEN): OPEN CIRCUIT / GROUND
B+	CA101-3	BATTERY POWER SUPPLY: B+
S	CA102-1	SCP +
S	CA102-2	SCP -
PG	CA102-12	POWER GROUND: GROUND
I	CA102-13	BRAKE ON / OFF SWITCH (NORMALLY OPEN): OPEN CIRCUIT / B+

Fig. 14.1

COMPONENTS

Component	Connector(s)	Connector Description	Location
CENTER CONSOLE SWITCH PACK	FC113	8-WAY / BLACK	CENTER CONSOLE
	FC119	8-WAY / BLACK	
	DT5	10-WAY / BLACK	DRIVER DOOR
	DD2	26-WAY / YELLOW	DRIVER DOOR ARM REST
	CA78	5-WAY / GREEN	LH REAR DOOR ARM REST
	PD1	5-WAY / GREEN	PASSENGER DOOR ARM REST
	CA95	5-WAY / GREEN	RH REAR DOOR ARM REST
	CA85	12-WAY / BLACK	DRIVER DOOR
	DD4	26-WAY / NATURAL	
	DT2	20-WAY / BLACK	
REAR ELECTRONIC MODULE	CA63	17-WAY / BLACK	LUGGAGE COMPARTMENT, RH REAR
	CA100	12-WAY / BLACK	
	CA101	20-WAY / BLACK	
	CA102	22-WAY / BLACK	
	CA103	26-WAY / NATURAL	
	CA250	22-WAY / BLACK	ROOF HEADLINER
	CA253	10-WAY / GREY	ABOVE ROOF CONSOLE
	DT4	8-WAY / GREY	DRIVER DOOR
	CA79	8-WAY / GREY	LH REAR DOOR
	PT4	8-WAY / GREY	PASSENGER DOOR
ROOF CONSOLE	CA93	8-WAY / GREY	RH REAR DOOR
	CA250	22-WAY / BLACK	
	CA253	10-WAY / GREY	
	DT4	8-WAY / GREY	
	CA79	8-WAY / GREY	
	PT4	8-WAY / GREY	
SLIDING ROOF CONTROL MODULE	CA253	10-WAY / GREY	ABOVE ROOF CONSOLE
WINDOW MOTOR ASSEMBLY - DRIVER	DT4	8-WAY / GREY	DRIVER DOOR
WINDOW MOTOR ASSEMBLY - LH REAR	CA79	8-WAY / GREY	LH REAR DOOR
WINDOW MOTOR ASSEMBLY - PASSENGER	PT4	8-WAY / GREY	PASSENGER DOOR
WINDOW MOTOR ASSEMBLY - RH REAR	CA93	8-WAY / GREY	RH REAR DOOR

HARNESS IN-LINE CONNECTORS

Connector	Connector Description / Location	Location
DD8	16-WAY / BLUE / CABIN HARNESS TO DRIVER DOOR HARNESS	DRIVER DOOR
DT8	14-WAY / GREY / CABIN HARNESS TO DRIVER DOOR TRIM HARNESS	DRIVER DOOR
FC39	10-WAY / GREY / CABIN HARNESS TO FASCIA HARNESS	BEHIND INSTRUMENT PANEL, RH SIDE
FH1	22-WAY / DARK GREY / CABIN HARNESS TO FRONT HARNESS	RH 'A' POST, LOWER
PD4	10-WAY / GREY / CABIN HARNESS TO PASSENGER DOOR HARNESS	PASSENGER DOOR
PT1	14-WAY / GREY / CABIN HARNESS TO PASSENGER DOOR TRIM HARNESS	PASSENGER DOOR

GROUNDS

Ground	Location
CA30	LH LOWER 'A' POST, ADJACENT TO THE FRONT ELECTRONIC MODULE (REARWARD OF FH77)
CA50	RH LOWER 'A' POST, BELOW PRIMARY JUNCTION FUSE BOX
CA141	UNDER LH FRONT SEAT
CA154	UNDER RH FRONT SEAT
CA156	LUGGAGE COMPARTMENT, RH SIDE
FC38	UNDER CENTER OF INSTRUMENT PANEL, ON TRANSMISSION TUNNEL

FOR CONTROL MODULE PIN-OUT INFORMATION, UNFOLD PAGE TO LEFT.

The following abbreviations are used to represent values for Control Module Pin-Out data

I	Input	PG	Power Ground	C	CAN Network	D	Serial and Encoded Data
O	Output	SS	Sensor / Signal Supply V	S	SCP Network	V	Voltage (DC)
B+	Battery Voltage	SG	Sensor / Signal Ground	D2	D2B Network	PWM	Pulse Width Modulated

CAUTION: The information on this data page is furnished to aid the user in understanding circuit operation. THIS INFORMATION SHOULD BE USED FOR REFERENCE ONLY.

NOTE: The values listed are approximately those that can be expected at the control module connector pins with all circuit connections made and all components connected and fitted.

Refer to the front of this book for detailed information and illustrations regarding the location and identification of harnesses, relays, fuses, grounds, control modules and control module pins.

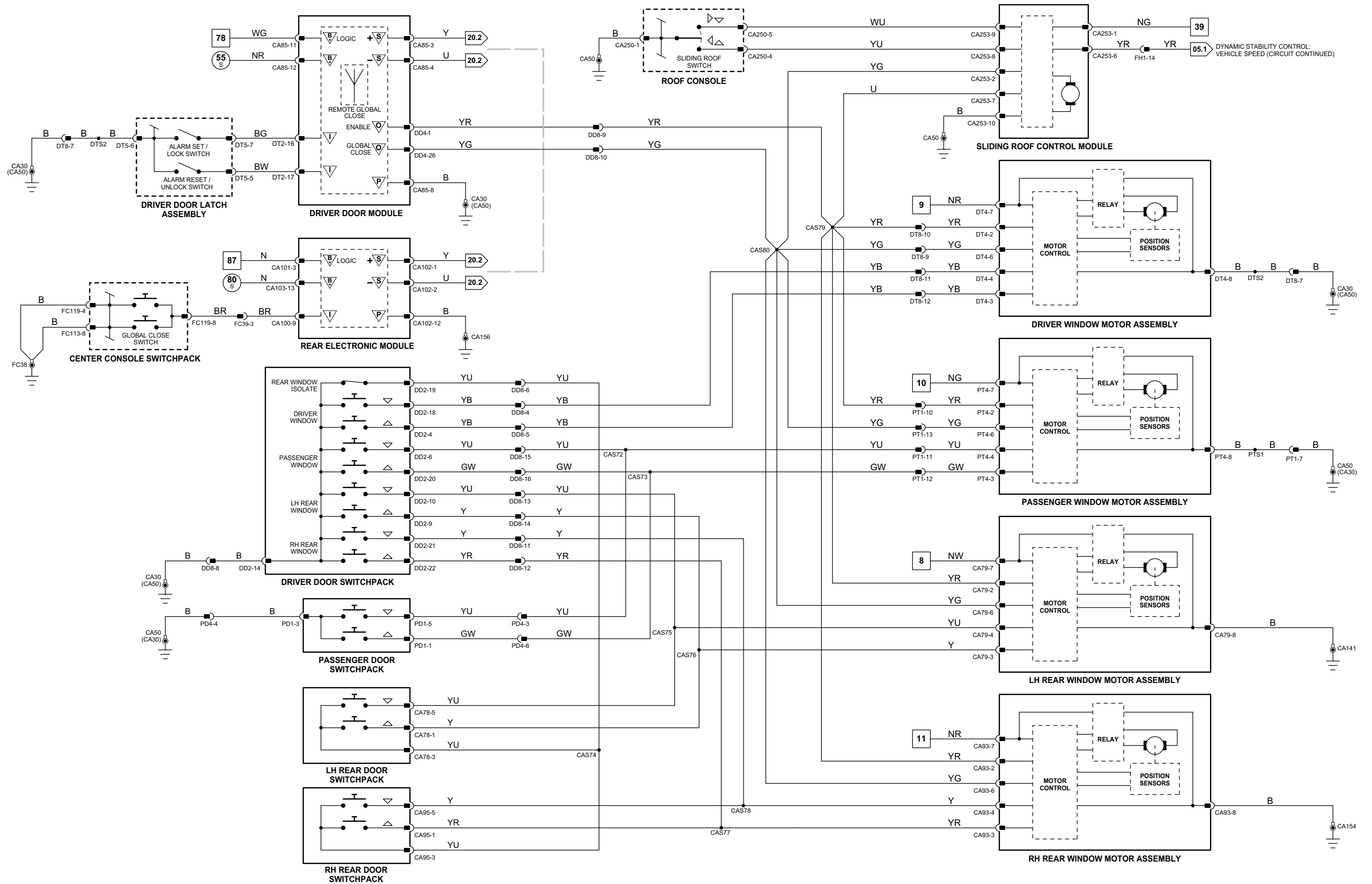

DYNAMIC STABILITY CONTROL: VEHICLE SPEED (CIRCUIT CONTINUED)

1 → 3
Fig. 01.1

4 → 76
Fig. 01.2

77 → 92
Fig. 01.3

1 → 14
Fig. 01.4

15 → 45
Fig. 01.5

46 → 80
Fig. 01.8

81 → 118
Fig. 01.7

Input
Output

Battery Voltage
Power Ground

Sensor/Signal Supply V
Sensor/Signal Ground

CAN
SCP
D2B Network
Serial and Encoded Data

VARIANT: All Vehicles
VIN RANGE: All
DATE OF ISSUE: April 2006

Audio Unit – Standard

	Pin	Description and Characteristic
PG	FC94-1	POWER GROUND: GROUND
B+	FC94-2	IGNITION SWITCHED POWER SUPPLY (I): B+
O	FC94-3	LH REAR AUDIO +
O	FC94-4	LH REAR AUDIO -
O	FC94-5	RH REAR AUDIO +
O	FC94-6	RH REAR AUDIO -
I	FC94-7	TELEPHONE MUTE SIGNAL
O	FC94-8	SECURITY SYSTEM GROUND SENSING: GROUND WHEN AUDIO UNIT INSTALLED
S	FC94-9	SCP +
S	FC94-10	SCP -
B+	FC94-11	BATTERY POWER SUPPLY: B+
O	FC94-13	LH FRONT AUDIO -
O	FC94-14	LH FRONT AUDIO +
O	FC94-15	RH FRONT AUDIO -
O	FC94-16	RH FRONT AUDIO +
I	FC94-17	DIMMER-CONTROLLED ILLUMINATION: PWM, 80 Hz, GROUND = 0% DUTY CYCLE, B+ = 100% DUTY CYCLE
I	FC94-18	STEERING WHEEL SWITCHES: STEPPED RESISTANCE
O	FC94-19	D2B NETWORK WAKE-UP
I	FC96-1	ANTENNA SIGNAL
SG	FC96-2	ANTENNA SHIELD
D2	FC108-1	D2B NETWORK TRANSMIT
D2	FC108-2	D2B NETWORK RECEIVE

Fig. 15.1

COMPONENTS

Component	Connector(s)	Connector Description	Location
AM / FM ANTENNA AMPLIFIER	CA220	NOT AVAILABLE	LH 'C' POST, ADJACENT TO REAR WINDOW
AUDIO UNIT	CA221	3-WAY / BLACK	
	FC94	20-WAY / BLACK	CENTER CONSOLE
	FC96	ANTENNA CONNECTOR	
CD AUTOCHANGER	FC108	FIBER OPTIC CONNECTOR	
	CA267	3-WAY / BLACK	LUGGAGE COMPARTMENT, LH REAR
HEATED REAR WINDOW	RA2	FIBER OPTIC CONNECTOR	
	CA20	2-WAY / GREY	CONNECTOR LOCATED BELOW PARCEL SHELF, LH SIDE
SPEAKER - LH FRONT	DT3 (LHD)	2-WAY / BLACK	LH FRONT DOOR
SPEAKER - LH REAR	PT2 (RHD)	2-WAY / BLACK	
	CA80	2-WAY / BLACK	LH REAR DOOR
SPEAKER - RH FRONT	DT3 (RHD)	2-WAY / BLACK	RH FRONT DOOR
	PT2 (LHD)	2-WAY / BLACK	
SPEAKER - RH REAR	CA92	2-WAY / BLACK	LH REAR DOOR
STEERING WHEEL AUDIO SWITCHES	SQ1	4-WAY / BLACK	STEERING WHEEL

HARNESS IN-LINE CONNECTORS

Connector	Connector Description / Location	Location
DT8	14-WAY / GREY / CABIN HARNESS TO DRIVER DOOR TRIM HARNESS	DRIVER DOOR
FC5	2-WAY / BLACK / FASCIA HARNESS (ANTENNA) TO CABIN HARNESS (ANTENNA)	BEHIND CENTER CONSOLE
FC10	14-WAY / GREEN / FASCIA HARNESS TO FRONT HARNESS	BEHIND INSTRUMENT PANEL, RH SIDE
FC23	10-WAY / GREY / CABIN HARNESS TO FASCIA HARNESS	BEHIND INSTRUMENT PANEL, LH SIDE
FC33	16-WAY / GREEN / CABIN HARNESS TO FASCIA HARNESS	BEHIND INSTRUMENT PANEL, RH SIDE
FC117	10-WAY / BLACK / STEERING WHEEL CASSETTE	STEERING COLUMN
PT1	14-WAY / GREY / CABIN HARNESS TO PASSENGER DOOR TRIM HARNESS	PASSENGER DOOR

GROUNDS

Ground	Location
CA21	LUGGAGE COMPARTMENT, LH SIDE AFT OF WHEEL ARCH
FC38	UNDER CENTER OF INSTRUMENT PANEL, ON TRANSMISSION TUNNEL

FOR CONTROL MODULE PIN-OUT INFORMATION, UNFOLD PAGE TO LEFT.

The following abbreviations are used to represent values for Control Module Pin-Out data

I	Input	PG	Power Ground	C	CAN Network	D	Serial and Encoded Data
O	Output	SS	Sensor / Signal Supply V	S	SCP Network	V	Voltage (DC)
B+	Battery Voltage	SG	Sensor / Signal Ground	D2	D2B Network	PWM	Pulse Width Modulated

CAUTION: The information on this data page is furnished to aid the user in understanding circuit operation. THIS INFORMATION SHOULD BE USED FOR REFERENCE ONLY.

NOTE: The values listed are approximately those that can be expected at the control module connector pins with all circuit connections made and all components connected and fitted.

Refer to the front of this book for detailed information and illustrations regarding the location and identification of harnesses, relays, fuses, grounds, control modules and control module pins.

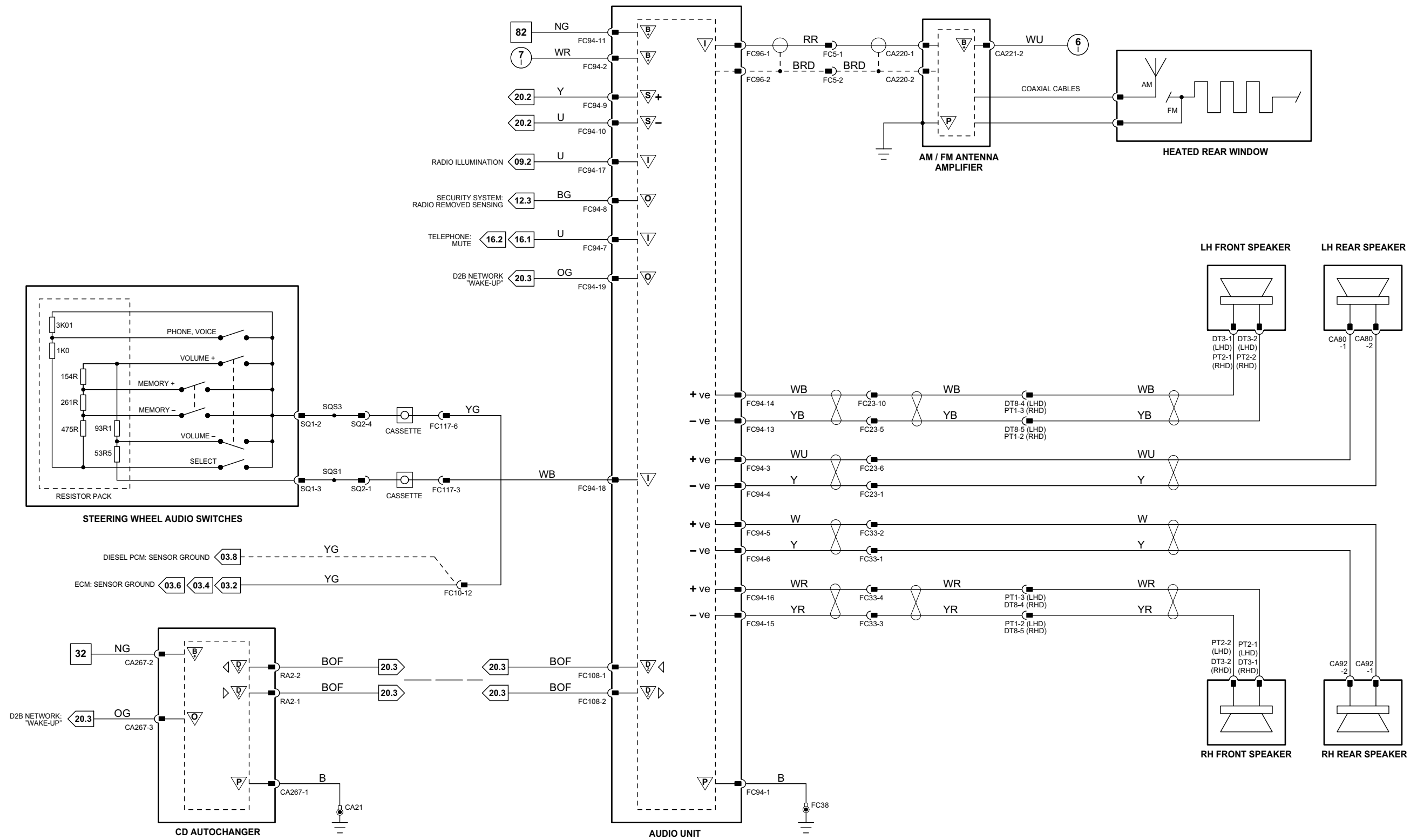

1 → 3 Fig. 01.1
 4 → 76 Fig. 01.2
 77 → 92 Fig. 01.3
 1 → 14 Fig. 01.4
 15 → 45 Fig. 01.5
 46 → 80 Fig. 01.6
 81 → 118 Fig. 01.7
 ▽ Input
 ▽ Battery Voltage
 ▽ Sensor/Signal Supply V
 ▽ CAN
 ▽ D2B Network
 ▽ Output
 ▽ Power Ground
 ▽ Sensor/Signal Ground
 ▽ SCP
 ▽ Serial and Encoded Data

VARIANT: Standard ICE Vehicles
VIN RANGE: All
DATE OF ISSUE: April 2006

Audio Unit – Premium

	Pin	Description and Characteristic
PG	FC94-1	POWER GROUND: GROUND
B+	FC94-2	IGNITION SWITCHED POWER SUPPLY (I): B+
I	FC94-7	TELEPHONE MUTE SIGNAL
O	FC94-8	SECURITY SYSTEM GROUND SENSING: GROUND WHEN AUDIO UNIT INSTALLED
S	FC94-9	SCP +
S	FC94-10	SCP -
B+	FC94-11	BATTERY POWER SUPPLY: B+
I	FC94-17	DIMMER-CONTROLLED ILLUMINATION: PWM, 80 Hz, GROUND = 0% DUTY CYCLE, B+ = 100% DUTY CYCLE
I	FC94-18	STEERING WHEEL SWITCHES: STEPPED RESISTANCE
O	FC94-19	D2B NETWORK WAKE-UP
I	FC96-1	ANTENNA SIGNAL
SG	FC96-2	ANTENNA SHIELD
D2	FC108-1	D2B NETWORK TRANSMIT
D2	FC108-2	D2B NETWORK RECEIVE

Fig. 15.2

COMPONENTS

Component	Connector(s)	Connector Description	Location
AM / FM ANTENNA AMPLIFIER	CA220	NOT AVAILABLE	LH 'C' POST, ADJACENT TO REAR WINDOW
	CA221	3-WAY / BLACK	
AUDIO UNIT	FC94	20-WAY / BLACK	CENTER CONSOLE
	FC96	ANTENNA CONNECTOR	
	FC108	FIBER OPTIC CONNECTOR	
CD AUTOCHANGER	CA267	3-WAY / BLACK	LUGGAGE COMPARTMENT, LH REAR
	RA2	FIBER OPTIC CONNECTOR	
HEATED REAR WINDOW	CA20	2-WAY / GREY	CONNECTOR LOCATED BELOW PARCEL SHELF, LH SIDE
POWER AMPLIFIER	CA263	POWER AMPLIFIER CONNECTOR	LUGGAGE COMPARTMENT, LH REAR
	CA264	POWER AMPLIFIER CONNECTOR	
	RA6	FIBER OPTIC CONNECTOR	
SPEAKER – LH FRONT	CA276	4-WAY / WHITE	LH FRONT DOOR
SPEAKER – LH REAR	CA277	4-WAY / WHITE	LH REAR DOOR
SPEAKER – RH FRONT	CA275	4-WAY / WHITE	RH FRONT DOOR
SPEAKER – RH REAR	CA278	4-WAY / WHITE	RH REAR DOOR
STEERING WHEEL AUDIO SWITCHES	SQ1	4-WAY / BLACK	STEERING WHEEL
SUBWOOFER – LH	CA6	2-WAY / WHITE	PARCEL SHELF, LH SIDE
SUBWOOFER – RH	CA5	2-WAY / WHITE	PARCEL SHELF, RH SIDE

HARNESS IN-LINE CONNECTORS

Connector	Connector Description / Location	Location
FC5	2-WAY / BLACK / FASCIA HARNESS (ANTENNA) TO CABIN HARNESS (ANTENNA)	BEHIND CENTER CONSOLE
FC10	14-WAY / GREEN / FASCIA HARNESS TO FRONT HARNESS	BEHIND INSTRUMENT PANEL, RH SIDE
FC117	10-WAY / BLACK / STEERING WHEEL CASSETTE	STEERING COLUMN

GROUNDS

Ground	Location
CA21	LUGGAGE COMPARTMENT, LH SIDE AFT OF WHEEL ARCH
FC38	UNDER CENTER OF INSTRUMENT PANEL, ON TRANSMISSION TUNNEL

FOR CONTROL MODULE PIN-OUT INFORMATION, UNFOLD PAGE TO LEFT.

The following abbreviations are used to represent values for Control Module Pin-Out data

I	Input	PG	Power Ground	C	CAN Network	D	Serial and Encoded Data
O	Output	SS	Sensor / Signal Supply V	S	SCP Network	V	Voltage (DC)
B+	Battery Voltage	SG	Sensor / Signal Ground	D2	D2B Network	PWM	Pulse Width Modulated

CAUTION: The information on this data page is furnished to aid the user in understanding circuit operation. THIS INFORMATION SHOULD BE USED FOR REFERENCE ONLY.

NOTE: The values listed are approximately those that can be expected at the control module connector pins with all circuit connections made and all components connected and fitted.

Refer to the front of this book for detailed information and illustrations regarding the location and identification of harnesses, relays, fuses, grounds, control modules and control module pins.

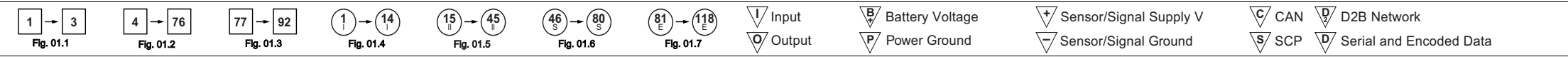
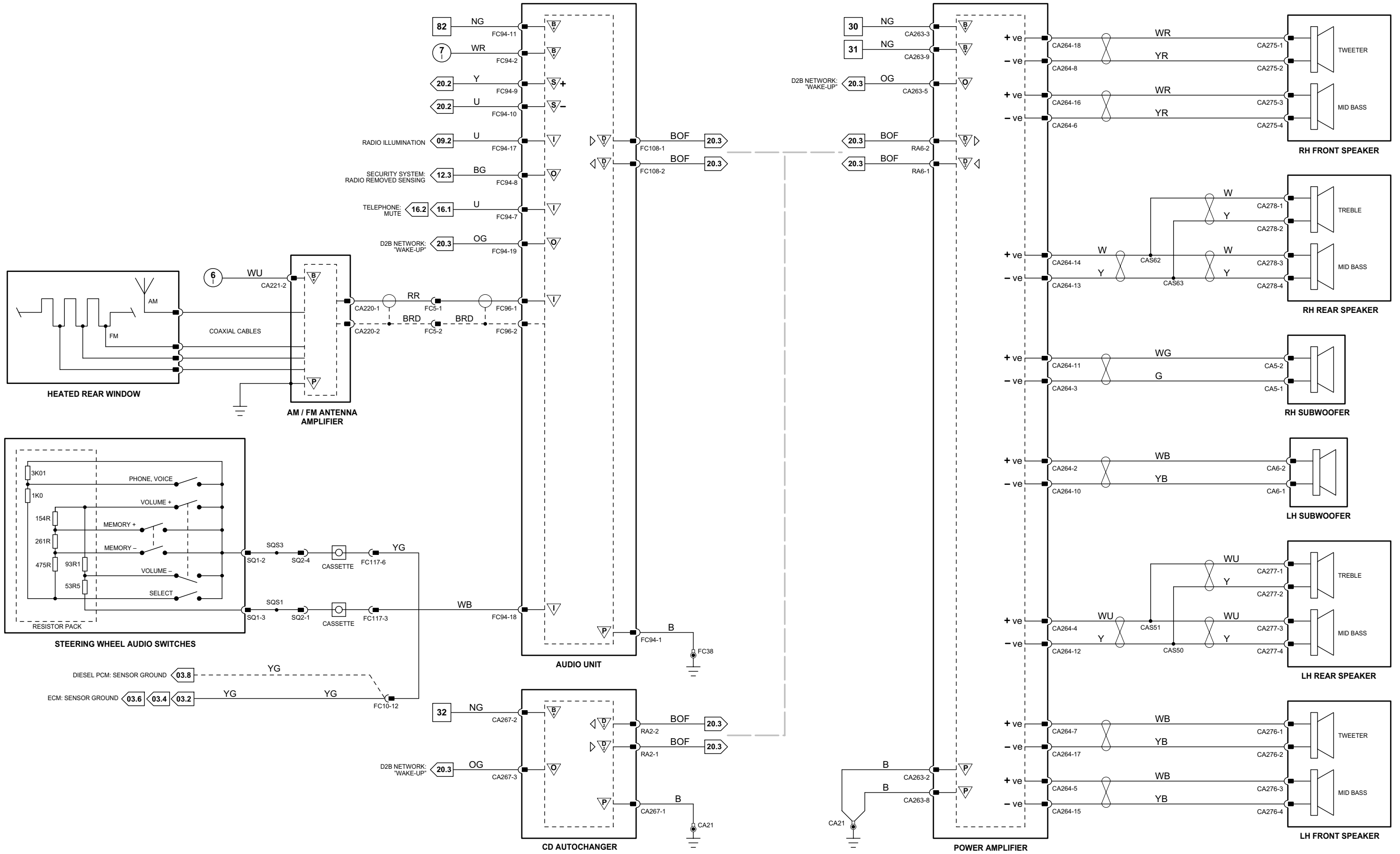

VARIANT: Premium ICE Vehicles
 VIN RANGE: All
 DATE OF ISSUE: April 2006

Audio Unit

Pin	Description and Characteristic
I FC94-7	TELEPHONE MUTE SIGNAL

Cellular Phone Control Module

Pin	Description and Characteristic
O CA261-1	PHONE BATTERY CHARGING SUPPLY
O CA261-2	HANDS FREE AUDIO TO PHONE
O CA261-3	PHONE ON / OFF (RESPONSE TO INCOMING AUDIO)
O CA261-4	MUTE COMMAND
O CA261-6	PHONE BATTERY VOLTAGE
PG CA261-9	POWER GROUND: GROUND
SG CA261-10	ANALOG GROUND: GROUND
SG CA261-11	MICROPHONE SHIELD: GROUND
B+ CA261-12	BATTERY POWER SUPPLY: B+
B+ CA261-13	BATTERY POWER SUPPLY: B+
B+ CA261-14	IGNITION SWITCHED POWER SUPPLY (I): B+
I CA261-17	MICROPHONE +
I CA261-18	MICROPHONE -
D CA261-20	TELEPHONE SERIAL COMMUNICATIONS DATA
SG CA261-21	TELEPHONE SHIELD: GROUND
D CA261-22	TELEPHONE SERIAL COMMUNICATIONS DATA
I CA261-23	D2B NETWORK WAKE-UP
I CA261-25	POWER GROUND: GROUND
I CA261-26	TELEPHONE LOGIC GROUND: GROUND
I CA261-29	IGNITION SWITCHED POWER SUPPLY (II): B+
D2 RA3-1	D2B NETWORK RECEIVE
D2 RA3-2	D2B NETWORK TRANSMIT

Fig. 16.1

COMPONENTS

Component	Connector(s)	Connector Description	Location
AUDIO UNIT	FC94	20-WAY / BLACK	CENTER CONSOLE
	FC96	ANTENNA CONNECTOR	
	FC108	FIBER OPTIC CONNECTOR	
CELLULAR PHONE CONTROL MODULE	CA261	32-WAY / BLACK	LUGGAGE COMPARTMENT, LH REAR
	RA3	FIBER OPTIC CONNECTOR	
	RA3	FIBER OPTIC CONNECTOR	
	CA216	10-WAY / GREY	CENTER CONSOLE
HAND SET RECEIVER	CA176	2-WAY / GREY	LUGGAGE COMPARTMENT, LH REAR
NAVIGATION CONTROL MODULE	CA257	26-WAY / NATURAL	
	CA258	20-WAY / BLACK	
	CA259	12-WAY / BLACK	
	RA5	FIBER OPTIC CONNECTOR	
	CA250	22-WAY / BLACK	ROOF HEADLINER
ROOF CONSOLE	FC92	22-WAY / BLACK	CENTER CONSOLE
TELEMATICS DISPLAY			

HARNES IN-LINE CONNECTORS

Connector	Connector Description / Location	Location
FC23	10-WAY / GREY / CABIN HARNESS TO FASCIA HARNESS	BEHIND INSTRUMENT PANEL, LH SIDE

GROUNDS

Ground	Location
CA21	LUGGAGE COMPARTMENT, LH SIDE AFT OF WHEEL ARCH

FOR CONTROL MODULE PIN-OUT INFORMATION, UNFOLD PAGE TO LEFT.

The following abbreviations are used to represent values for Control Module Pin-Out data

I	Input	PG	Power Ground	C	CAN Network	D	Serial and Encoded Data
O	Output	SS	Sensor / Signal Supply V	S	SCP Network	V	Voltage (DC)
B+	Battery Voltage	SG	Sensor / Signal Ground	D2	D2B Network	PWM	Pulse Width Modulated

CAUTION: The information on this data page is furnished to aid the user in understanding circuit operation. THIS INFORMATION SHOULD BE USED FOR REFERENCE ONLY.

NOTE: The values listed are approximately those that can be expected at the control module connector pins with all circuit connections made and all components connected and fitted.

Refer to the front of this book for detailed information and illustrations regarding the location and identification of harnesses, relays, fuses, grounds, control modules and control module pins.

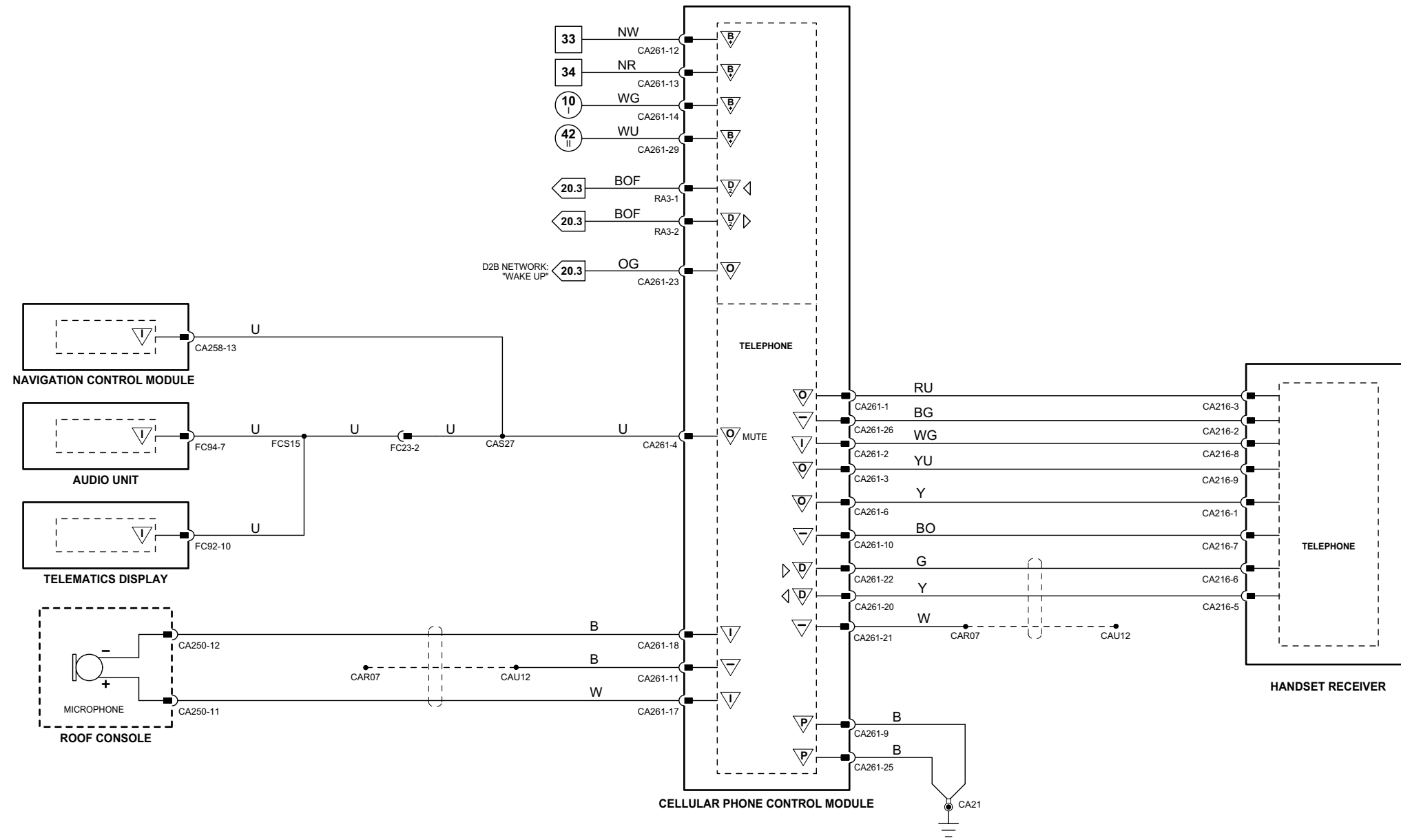

VARIANT: Telephone only Vehicles
 VIN RANGE: All
 DATE OF ISSUE: April 2006

Fig. 16.2

Audio Unit

Pin	Description and Characteristic
I FC94-7	TELEPHONE MUTE SIGNAL

Cellular Phone Control Module

Pin	Description and Characteristic
O CA261-1	PHONE BATTERY CHARGING SUPPLY
O CA261-2	HANDS FREE AUDIO TO PHONE
O CA261-3	PHONE ON / OFF (RESPONSE TO INCOMING AUDIO)
O CA261-4	MUTE COMMAND
I CA261-6	PHONE BATTERY VOLTAGE
PG CA261-9	POWER GROUND: GROUND
SG CA261-10	ANALOG GROUND: GROUND
SG CA261-11	MICROPHONE SHIELD: GROUND
B+ CA261-12	BATTERY POWER SUPPLY: B+
B+ CA261-13	BATTERY POWER SUPPLY: B+
B+ CA261-14	IGNITION SWITCHED POWER SUPPLY (I): B+
I CA261-17	MICROPHONE +
I CA261-18	MICROPHONE -
D CA261-20	TELEPHONE SERIAL COMMUNICATIONS DATA
SG CA261-21	TELEPHONE SHIELD: GROUND
D CA261-22	TELEPHONE SERIAL COMMUNICATIONS DATA
I CA261-23	D2B NETWORK WAKE-UP
I CA261-25	POWER GROUND: GROUND
I CA261-26	TELEPHONE LOGIC GROUND: GROUND
I CA261-29	IGNITION SWITCHED POWER SUPPLY (II): B+
D2 RA3-1	D2B NETWORK RECEIVE
D2 RA3-2	D2B NETWORK TRANSMIT

COMPONENTS

Component	Connector(s)	Connector Description	Location
AUDIO UNIT	FC94	20-WAY / BLACK	CENTER CONSOLE
	FC96	ANTENNA CONNECTOR	
	FC108	FIBER OPTIC CONNECTOR	
CELLULAR PHONE CONTROL MODULE	CA261	32-WAY / BLACK	LUGGAGE COMPARTMENT, LH REAR
	RA3	FIBER OPTIC CONNECTOR	
	CA216	10-WAY / GREY	CENTER CONSOLE
HAND SET RECEIVER	CA176	2-WAY / GREY	LUGGAGE COMPARTMENT, LH REAR
NAVIGATION CONTROL MODULE	CA257	26-WAY / NATURAL	
	CA258	20-WAY / BLACK	
	CA259	12-WAY / BLACK	
	RA5	FIBER OPTIC CONNECTOR	
	CA250	22-WAY / BLACK	ROOF HEADLINER
ROOF CONSOLE	CA250	22-WAY / BLACK	ROOF HEADLINER
STEERING WHEEL AUDIO SWITCHES	SQ1	4-WAY / BLACK	STEERING WHEEL
TELEMATICS DISPLAY	FC92	22-WAY / BLACK	CENTER CONSOLE
TELEPHONE ANTENNA	CA9	ANTENNA CONNECTOR	REAR BUMPER, LH SIDE

HARNESS IN-LINE CONNECTORS

Connector	Connector Description / Location	Location
FC10	14-WAY / GREEN / FASCIA HARNESS TO FRONT HARNESS	BEHIND INSTRUMENT PANEL, RH SIDE
FC23	10-WAY / GREY / CABIN HARNESS TO FASCIA HARNESS	BEHIND INSTRUMENT PANEL, LH SIDE
FC117	10-WAY / BLACK / STEERING WHEEL CASSETTE	STEERING COLUMN

GROUNDS

Ground	Location
CA21	LUGGAGE COMPARTMENT, LH SIDE AFT OF WHEEL ARCH

FOR CONTROL MODULE PIN-OUT INFORMATION, UNFOLD PAGE TO LEFT.

The following abbreviations are used to represent values for Control Module Pin-Out data

I	Input	PG	Power Ground	C	CAN Network	D	Serial and Encoded Data
O	Output	SS	Sensor / Signal Supply V	S	SCP Network	V	Voltage (DC)
B+	Battery Voltage	SG	Sensor / Signal Ground	D2	D2B Network	PWM	Pulse Width Modulated

CAUTION: The information on this data page is furnished to aid the user in understanding circuit operation. THIS INFORMATION SHOULD BE USED FOR REFERENCE ONLY.

NOTE: The values listed are approximately those that can be expected at the control module connector pins with all circuit connections made and all components connected and fitted.

Refer to the front of this book for detailed information and illustrations regarding the location and identification of harnesses, relays, fuses, grounds, control modules and control module pins.

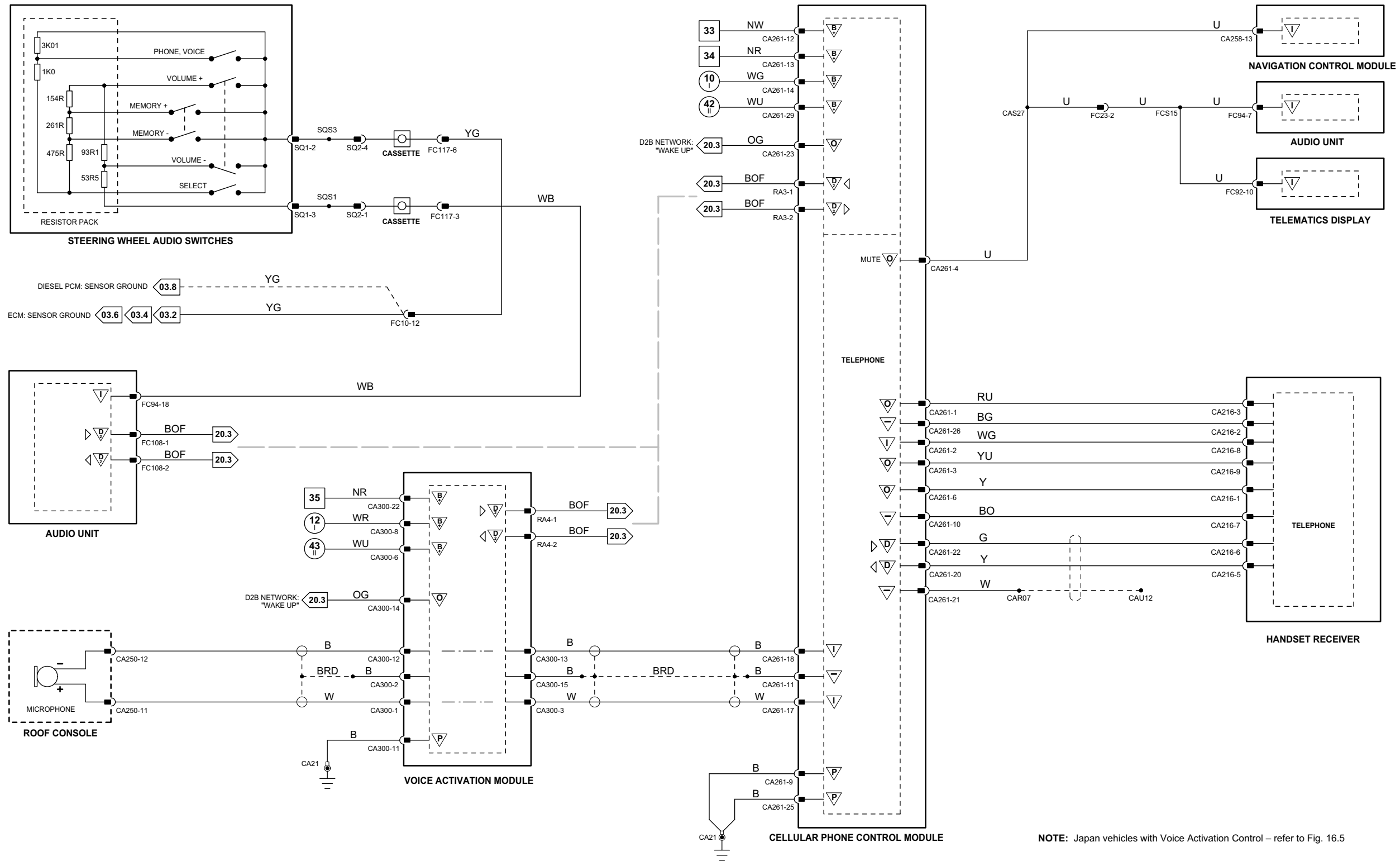

NOTE: Japan vehicles with Voice Activation Control – refer to Fig. 16.5

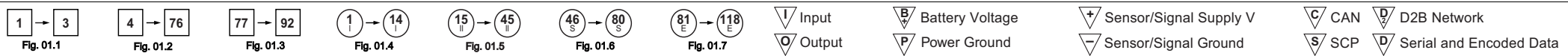

VARIANT: Telephone with Voice Vehicles
 VIN RANGE: All
 DATE OF ISSUE: April 2006

Fig. 16.3**COMPONENTS**

Component	Connector(s)	Connector Description	Location
AUDIO UNIT	FC94	20-WAY / BLACK	CENTER CONSOLE
	FC96	ANTENNA CONNECTOR	
	FC108	FIBER OPTIC CONNECTOR	
ROOF CONSOLE	CA250	22-WAY / BLACK	ROOF HEADLINER
STEERING WHEEL AUDIO SWITCHES	SQ1	4-WAY / BLACK	STEERING WHEEL
VOICE ACTIVATION MODULE	CA300	22-WAY / GREY	LUGGAGE COMPARTMENT, LH REAR
	RA4	FIBER OPTIC CONNECTOR	

HARNES IN-LINE CONNECTORS

Connector	Connector Description / Location	Location
FC10	14-WAY / GREEN / FASCIA HARNESS TO FRONT HARNESS	BEHIND INSTRUMENT PANEL, RH SIDE
FC117	10-WAY / BLACK / STEERING WHEEL CASSETTE	STEERING COLUMN

GROUNDS

Ground	Location
CA21	LUGGAGE COMPARTMENT, LH SIDE AFT OF WHEEL ARCH

Refer to the front of this book for detailed information and illustrations regarding the location and identification of harnesses, relays, fuses, grounds, control modules and control module pins.

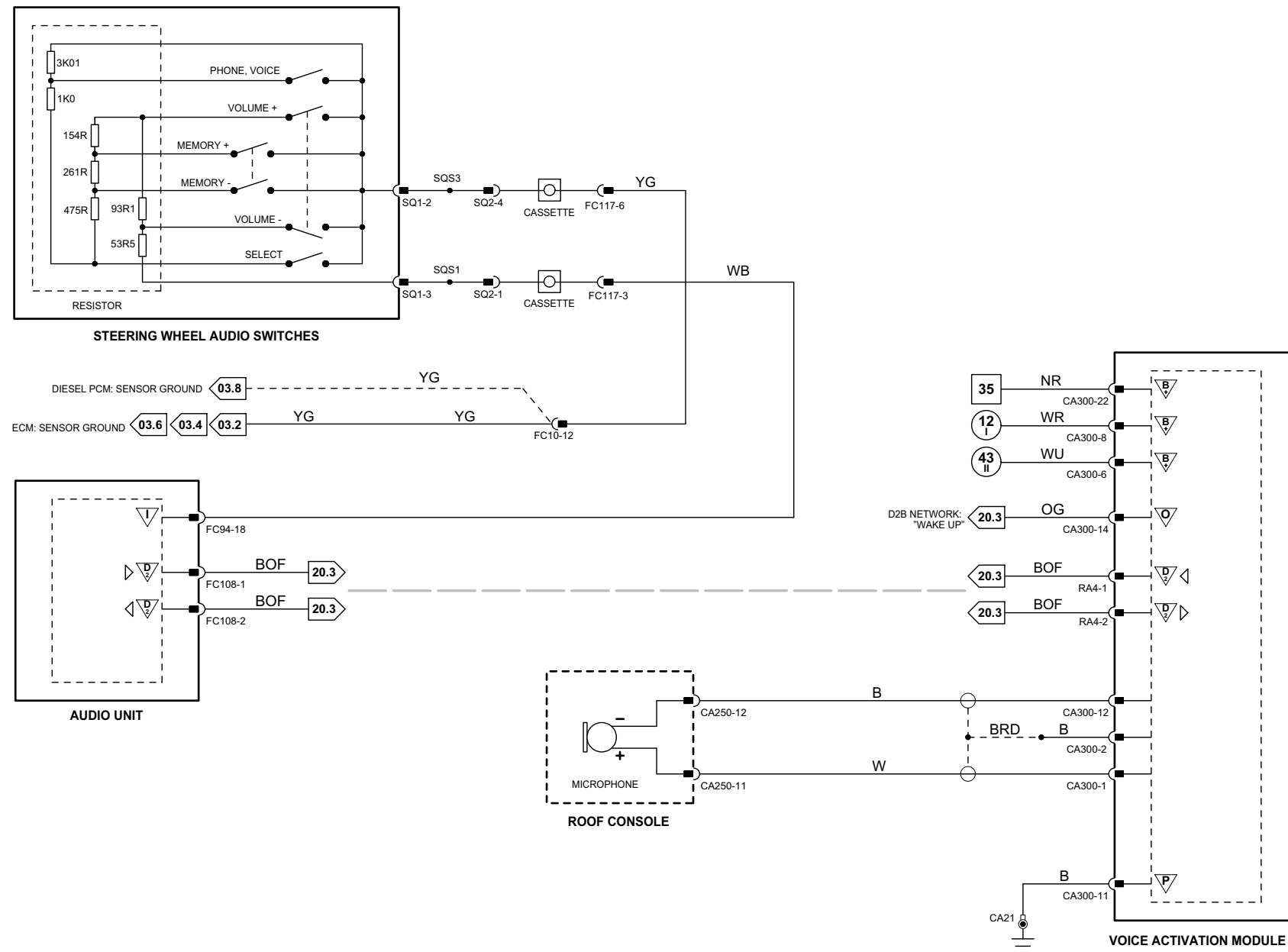

NOTE: Japan vehicles with voice activation control – Refer to Fig. 16.5



VARIANT: Voice Only Vehicles
 VIN RANGE: All
 DATE OF ISSUE: April 2006

Fig. 16.4**COMPONENTS**

Component	Connector(s)	Connector Description	Location
NAVIGATION CONTROL MODULE	CA176	2-WAY / GREY	LUGGAGE COMPARTMENT, LH REAR
	CA257	26-WAY / NATURAL	
	CA258	20-WAY / BLACK	
	CA259	12-WAY / BLACK	
	RA5	FIBER OPTIC CONNECTOR	
NAVIGATION GPS ANTENNA	CA175	2-WAY / GREY	PARCEL SHELF, CENTER
NAVIGATION SCREEN AND TELEMATICS DISPLAY	FC92	22-WAY / BLACK	CENTER CONSOLE
	FC102	2-WAY GREY	
	FC103	2-WAY GREY	
	FC104	2-WAY GREY	
	FC105	2-WAY GREY	

HARNESS IN-LINE CONNECTORS

Connector	Connector Description / Location	Location
FC16	10-WAY / GREY / CABIN HARNESS TO FASCIA HARNESS	BEHIND INSTRUMENT PANEL, LH SIDE
FC19	16-WAY / GREEN / CABIN HARNESS TO FASCIA HARNESS	BEHIND INSTRUMENT PANEL, LH SIDE

GROUNDS

Ground	Location
FC38	UNDER CENTER OF INSTRUMENT PANEL, ON TRANSMISSION TUNNEL

Refer to the front of this book for detailed information and illustrations regarding the location and identification of harnesses, relays, fuses, grounds, control modules and control module pins.

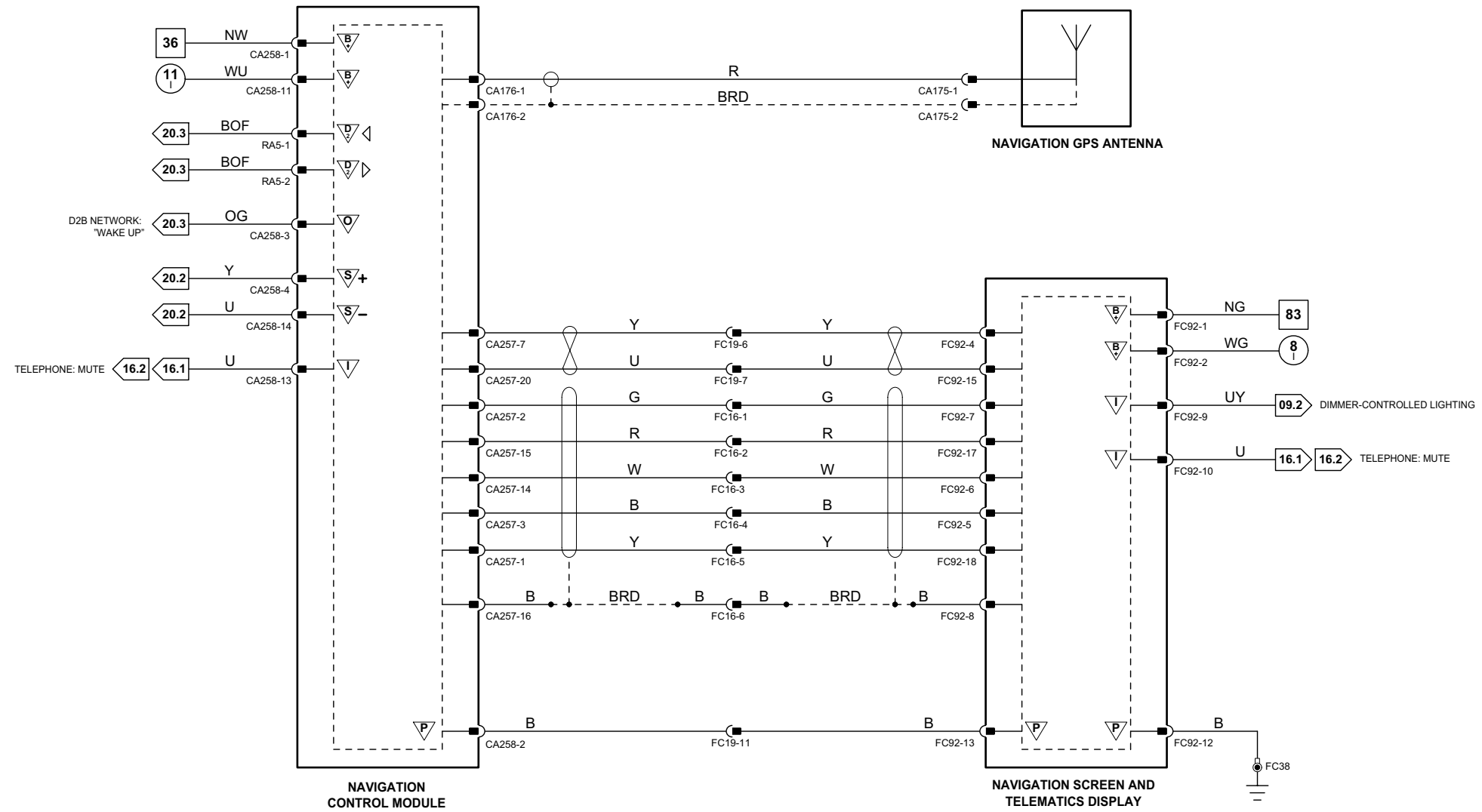

Fig. 16.5**COMPONENTS**

Component	Connector(s)	Connector Description	Location
NAVIGATION CONTROL MODULE	CA176	2-WAY / GREY	LUGGAGE COMPARTMENT, LH REAR
	CA257	26-WAY / NATURAL	
	CA258	20-WAY / BLACK	
	CA259	12-WAY / BLACK	
	RA5	FIBER OPTIC CONNECTOR	
NAVIGATION GPS ANTENNA	CA175	2-WAY / GREY	PARCEL SHELF, CENTER
NAVIGATION SCREEN AND TELEMATICS DISPLAY	FC92	22-WAY / BLACK	CENTER CONSOLE
	FC102	2-WAY GREY	
	FC103	2-WAY GREY	
	FC104	2-WAY GREY	
	FC105	2-WAY GREY	
ROOF CONSOLE	CA250	22-WAY / BLACK	ROOF HEADLINER
TV ANTENNA AND AMPLIFIER 1	CA198	2-WAY / GREY	PARCEL SHELF
TV ANTENNA AND AMPLIFIER 2	CA200	2-WAY / GREY	PARCEL SHELF
TV ANTENNA AND AMPLIFIER 3	CA202	2-WAY / GREY	PARCEL SHELF
TV ANTENNA AND AMPLIFIER 4	CA204	2-WAY / GREY	PARCEL SHELF
VEHICLE INFORMATION ANTENNA	CA208	ANTENNA CONNECTOR	PARCEL SHELF
VEHICLE INFORMATION CONTROL MODULE	CA207	ANTENNA CONNECTOR	LUGGAGE COMPARTMENT, LH SIDE
	CA268	ANTENNA CONNECTOR	
	CA273	10-WAY / BLACK	
VEHICLE INFORMATION SENSOR	FC95	ANTENNA CONNECTOR	INSTRUMENT PANEL

HARNES IN-LINE CONNECTORS

Connector	Connector Description / Location	Location
FC16	10-WAY / GREY / CABIN HARNESS TO FASCIA HARNESS	BEHIND INSTRUMENT PANEL, LH SIDE
FC19	16-WAY / GREEN / CABIN HARNESS TO FASCIA HARNESS	BEHIND INSTRUMENT PANEL, LH SIDE
FC93	2-WAY / BLACK / FASCIA HARNESS (ANTENNA) TO CABIN HARNESS (ANTENNA)	BEHIND INSTRUMENT PANEL
FC98	4-WAY / BLACK / FASCIA HARNESS (ANTENNA) TO CABIN HARNESS (ANTENNA)	BEHIND INSTRUMENT PANEL, LH SIDE
FC99	4-WAY / BLACK / FASCIA HARNESS (ANTENNA) TO CABIN HARNESS (ANTENNA)	BEHIND INSTRUMENT PANEL, RH SIDE

GROUNDS

Ground	Location
CA21	LUGGAGE COMPARTMENT, LH SIDE AFT OF WHEEL ARCH
FC38	UNDER CENTER OF INSTRUMENT PANEL, ON TRANSMISSION TUNNEL

Refer to the front of this book for detailed information and illustrations regarding the location and identification of harnesses, relays, fuses, grounds, control modules and control module pins.

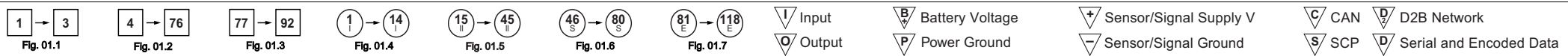
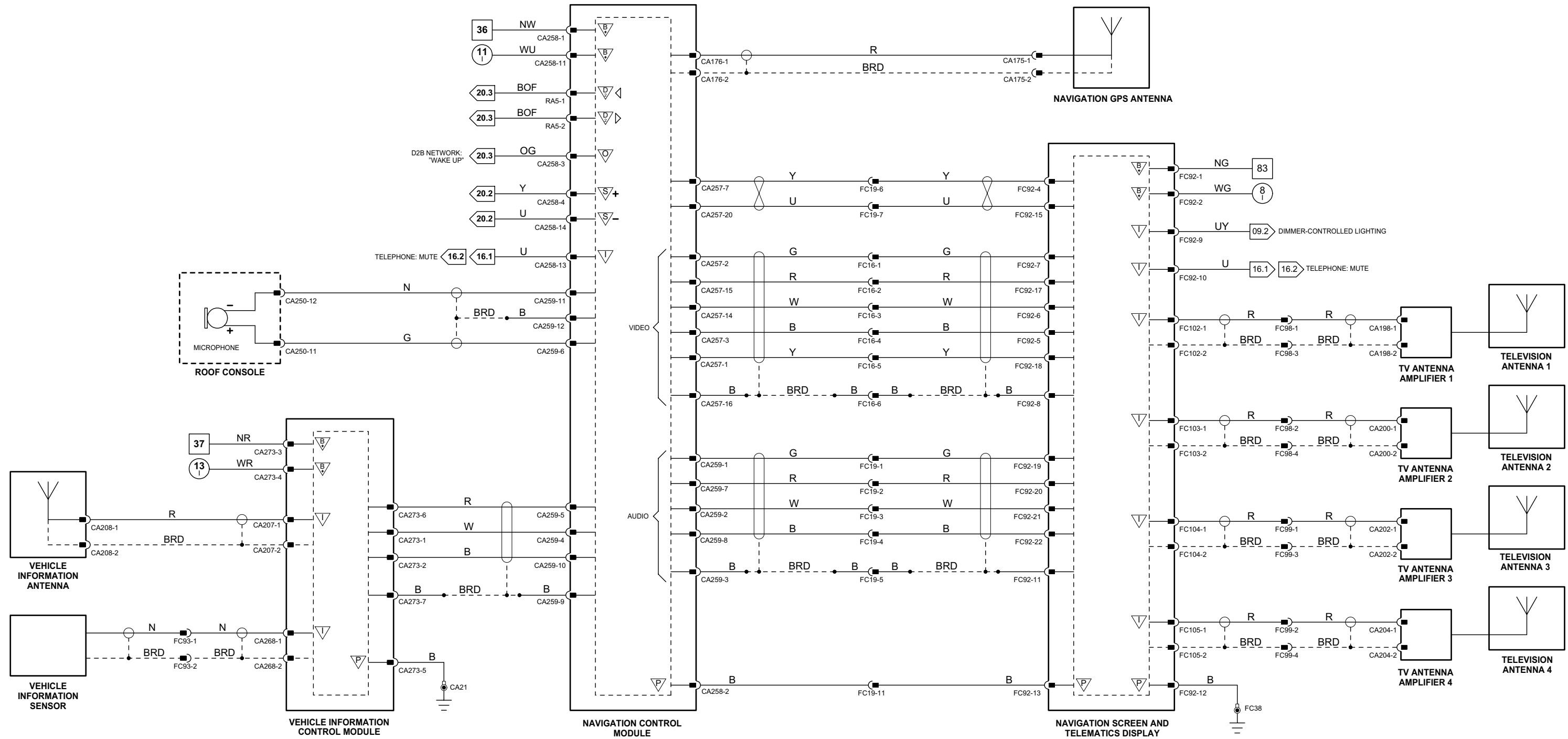

VARIANT: Japan Navigation Vehicles
 VIN RANGE: All
 DATE OF ISSUE: April 2006

Fig. 17.1**COMPONENTS**

Component	Connector(s)	Connector Description	Location
AIR BAG IGNITER – DRIVER, CURTAIN	CA226	2-WAY / YELLOW	HEADLINER, DRIVER SIDE
AIR BAG IGNITERS – DRIVER DUAL	SW11	2-WAY / BLACK	STEERING WHEEL
	SW12	2-WAY / BLACK	
AIR BAG IGNITER – DRIVER, SIDE	DB4	2-WAY / YELLOW	DRIVER SEAT, SET BACK
AIR BAG IGNITER – PASSENGER, CURTAIN	CA288	2-WAY / YELLOW	HEADLINER, PASSENGER SIDE
AIR BAG IGNITER – PASSENGER, SIDE	PB4	2-WAY / YELLOW	PASSENGER SEAT, SEAT BACK
DRIVER SEAT POSITION SWITCH	DM41	2-WAY / BLACK	DRIVER SEAT TRACK, LH SIDE
IMPACT SENSOR – DRIVER REAR SIDE	CA230	2-WAY / BLACK	LH 'D' POST
IMPACT SENSOR – DRIVER SIDE	CA22	2-WAY / BLACK	LH 'B/C' POST
IMPACT SENSOR – FRONT	FH102	2-WAY / BLACK	FRONT CROSS MEMBER, CENTER
IMPACT SENSOR – PASSENGER REAR SIDE	CA246	2-WAY / BLACK	RH 'D' POST
IMPACT SENSOR – PASSENGER SIDE	CA58	2-WAY / BLACK	RH 'B/C' POST
RESTRAINTS CONTROL MODULE	CA114	24-WAY / BLACK	TRANSMISSION TUNNEL, UNDER CENTER CONSOLE
	CA232	40-WAY / BLACK	
SEAT BELT PRETENSIONER IGNITER – CENTER REAR	CA224	2-WAY / YELLOW	SEAT BELT RETRACTOR
SEAT BELT PRETENSIONER IGNITER – DRIVER	DM20	4-WAY / GREY	SEAT BELT BUCKLE
SEAT BELT PRETENSIONER IGNITER – DRIVER SIDE REAR	CA225	2-WAY / YELLOW	SEAT BELT RETRACTOR
SEAT BELT PRETENSIONER IGNITER – PASSENGER	PN15	4-WAY / GREY	SEAT BELT BUCKLE
SEAT BELT PRETENSIONER IGNITER – PASSENGER SIDE REAR	CA223	2-WAY / YELLOW	SEAT BELT RETRACTOR
SEAT BELT SWITCH – DRIVER	DM20	4-WAY / GREY	SEAT BELT BUCKLE
SEAT BELT SWITCH – PASSENGER	PN15	4-WAY / GREY	SEAT BELT BUCKLE

HARNESS IN-LINE CONNECTORS

Connector	Connector Description / Location	Location
DM23	20-WAY / BLACK / CABIN HARNESS TO DRIVER SEAT HARNESS	UNDER DRIVER SEAT
DM40	4-WAY / GREY / DRIVER SEAT ADVANCED RESTRAINT SYSTEM IN-LINE CONNECTOR	UNDER DRIVER SEAT
FC42	4-WAY / GREY / CABIN HARNESS TO FASCIA HARNESS	BEHIND INSTRUMENT PANEL, DRIVER SIDE
FC117	10-WAY / BLACK / STEERING WHEEL CASSETTE	STEERING COLUMN
FH2	16-WAY / GREY / CABIN HARNESS TO FRONT HARNESS	RH 'A' POST, LOWER
PN24	20-WAY / BLACK / CABIN HARNESS TO PASSENGER SEAT HARNESS	UNDER PASSENGER SEAT
PN35	4-WAY / GREY / PASSENGER SEAT ADVANCED RESTRAINT SYSTEM IN-LINE CONNECTOR	UNDER PASSENGER SEAT
SW9	2-WAY / YELLOW / ADVANCED RESTRAINT SYSTEM / STEERING WHEEL CASSETTE	STEERING WHEEL
SW10	2-WAY / YELLOW / ADVANCED RESTRAINT SYSTEM / STEERING WHEEL CASSETTE	STEERING WHEEL

GROUNDS

Ground	Location
CA14	TRANSMISSION TUNNEL, UNDER CENTER CONSOLE
CA141	UNDER LH FRONT SEAT
CA154	UNDER RH FRONT SEAT

Refer to the front of this book for detailed information and illustrations regarding the location and identification of harnesses, relays, fuses, grounds, control modules and control module pins.

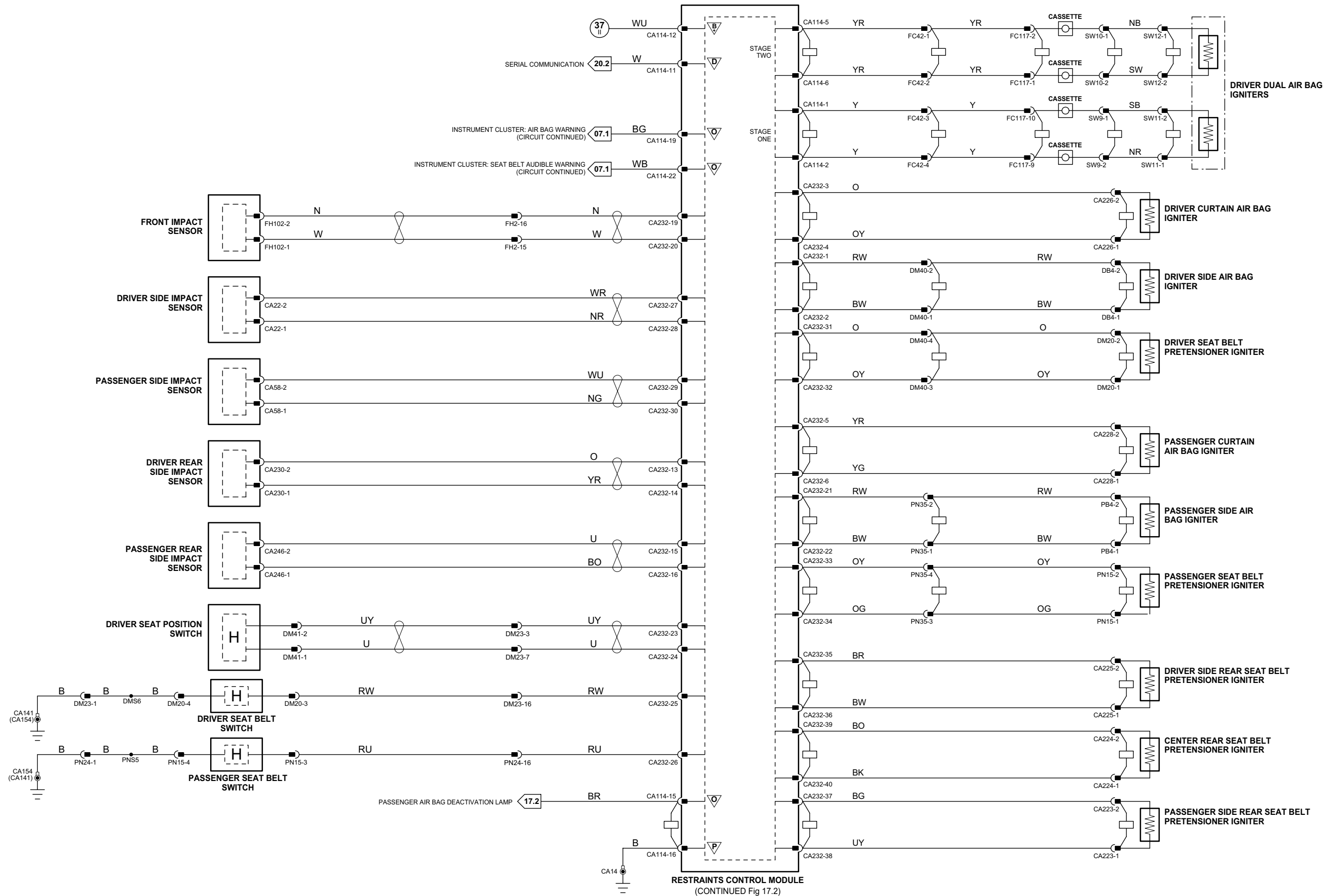

VARIANT: All Vehicles
 VIN RANGE: All
 DATE OF ISSUE: April 2006

Fig. 17.2**COMPONENTS**

Component	Connector(s)	Connector Description	Location
AIR BAG IGNITERS – PASSENGER DUAL	FC32	2-WAY / BROWN	INSTRUMENT PANEL
	FC46	2-WAY / BROWN	
OCCUPANCY SENSING CONTROL MODULE	PN38	26-WAY / WHITE	UNDER PASSENGER SEAT
PASSENGER AIR BAG DEACTIVATED INDICATOR LAMP	FC112	3-WAY / BLACK	PASSENGER AIRBAG 'DOOR'
PASSENGER SEAT WEIGHT PRESSURE SENSOR	PN41	3-WAY / BLACK	PASSENGER SEAT
PASSENGER SEAT WEIGHT SENSING CONTROL MODULE	PN37	10-WAY / BLACK	UNDER PASSENGER SEAT
RESTRAINTS CONTROL MODULE	CA114	24-WAY / BLACK	TRANSMISSION TUNNEL, UNDER CENTER CONSOLE
	CA232	40-WAY / BLACK	
SAFETY BELT TENSION SENSOR	PN42	4-WAY / GREY	UNDER PASSENGER SEAT
SPATIAL SENSOR – CENTER CONSOLE	FC3 (RHD)	2-WAY / GREY	CENTER CONSOLE
	FC114 (LHD)	2-WAY / GREY	
SPATIAL SENSOR – HEADLINER REAR INNER	RF41	2-WAY / BLACK	HEADLINER, ABOVE FRONT PASSENGER
SPATIAL SENSOR – HEADLINER REAR OUTER	RF40	2-WAY / BLACK	HEADLINER, ABOVE FRONT PASSENGER
SPATIAL SENSOR – PASSENGER 'A' POST	CA251	2-WAY / BLACK	PASSENGER SIDE 'A' POST

HARNES IN-LINE CONNECTORS

Connector	Connector Description / Location	Location
FC25	4-WAY / GREY / CABIN HARNESS TO FASCIA HARNESS	BEHIND INSTRUMENT PANEL, PASSENGER SIDE
FC33	16-WAY / GREEN / CABIN HARNESS TO FASCIA HARNESS	BEHIND INSTRUMENT PANEL, RH SIDE
PN24	20-WAY / BLACK / CABIN HARNESS TO PASSENGER SEAT HARNESS	UNDER PASSENGER SEAT
RF34	16-WAY / GREEN / CABIN HARNESS TO DOOR HARNESS	'D' POST, UNDER PARCEL SHELF

GROUNDS

Ground	Location
CA14	TRANSMISSION TUNNEL, UNDER CENTER CONSOLE
CA141	UNDER LH FRONT SEAT
CA154	UNDER RH FRONT SEAT

Refer to the front of this book for detailed information and illustrations regarding the location and identification of harnesses, relays, fuses, grounds, control modules and control module pins.

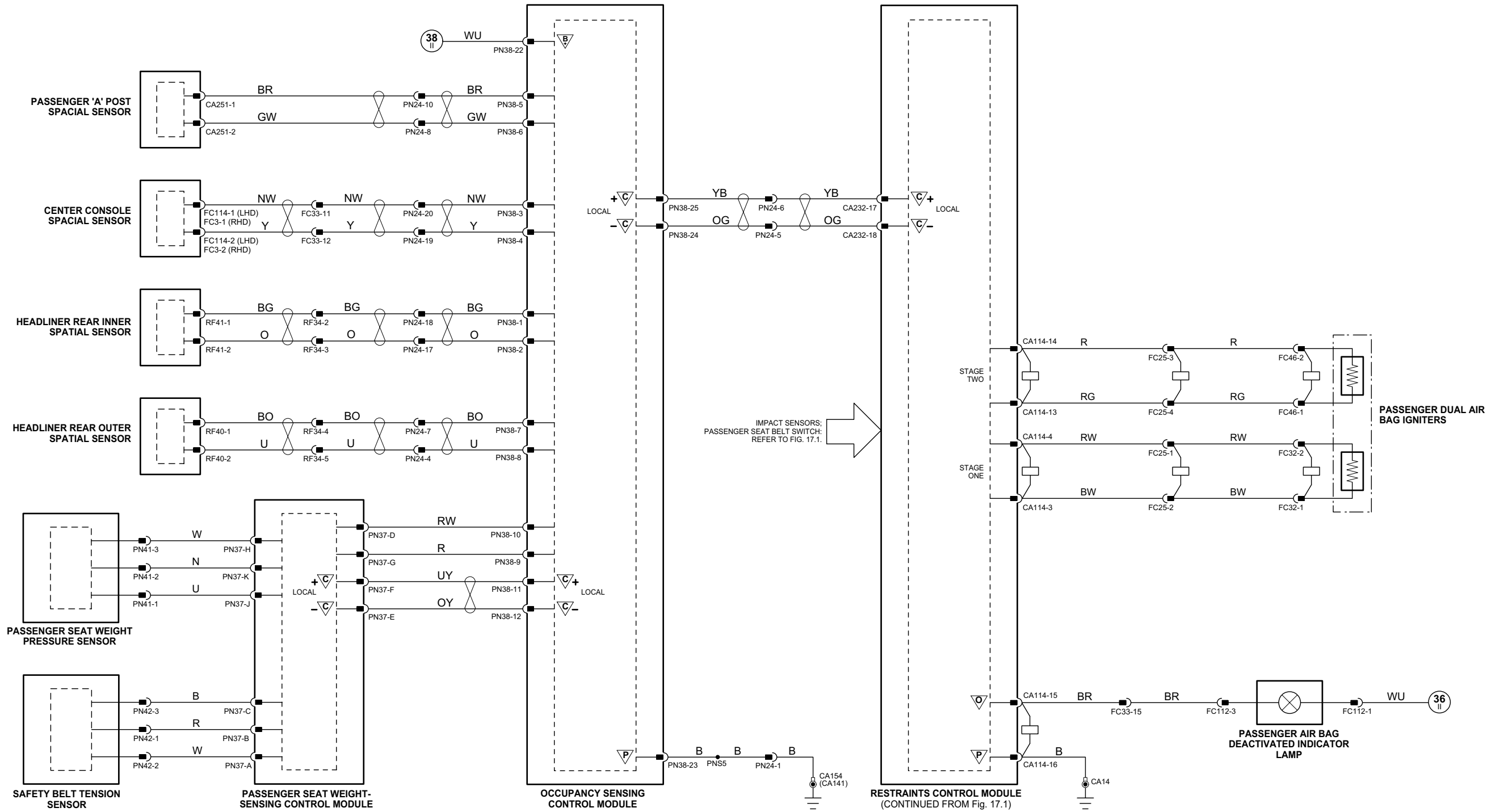

NOTE: RCM power supply shown on Fig. 17.1.

Parking Aid Module

	Pin	Description and Characteristic
B+	CA112-1	IGNITION SWITCHED POWER SUPPLY: B+
O	CA112-2	REAR SOUNDER -
I	CA112-4	PARKING AID SWITCH
I	CA112-5	TRAILER CONNECTED STATUS: GROUND = TRAILER CONNECTED
I	CA112-6	REVERSE LAMPS STATUS: B+ = REVERSE LAMPS ON
O	CA112-10	REAR SOUNDER +
D	CA112-12	SERIAL DATA LINK
O	CA112-13	PARKING AID STATUS LED
I	CA112-15	SPEED SIGNAL
PG	CA112-16	POWER GROUND: GROUND
PG	CA113-1	FRONT SENSORS GROUND: GROUND
O	CA113-2	FRONT SENSORS POWER SUPPLY: B+
O	CA113-3	FRONT SOUNDER OUTPUT
D	CA113-5	FRONT LH SENSOR SIGNAL DATA
D	CA113-6	FRONT LH CENTER SENSOR SIGNAL DATA
D	CA113-7	FRONT RH CENTER SENSOR SIGNAL DATA
D	CA113-8	FRONT RH SENSOR SIGNAL DATA
D	CA115-2	REAR RH CENTER SENSOR SIGNAL DATA
D	CA115-3	REAR LH CENTER SENSOR SIGNAL DATA
D	CA115-4	REAR RH SENSOR SIGNAL DATA
D	CA115-5	REAR LH SENSOR SIGNAL DATA
PG	CA115-8	REAR SENSORS GROUND: GROUND
O	CA115-11	REAR SENSORS POWER SUPPLY: B+

Fig. 18.1

COMPONENTS

Component	Connector(s)	Connector Description	Location
FRONT LH CENTER SENSOR	BF10	3-WAY / BLACK	FRONT BUMPER, LH, CENTER
FRONT LH SENSOR	BF11	3-WAY / BLACK	FRONT BUMPER, LH
FRONT RH CENTER SENSOR	BF9	3-WAY / BLACK	FRONT BUMPER, RH CENTER
FRONT RH SENSOR	BF8	3-WAY / BLACK	FRONT BUMPER, RH
PARKING AID MODULE	CA112	12-WAY / BLACK	LUGGAGE COMPARTMENT, LH REAR
	CA113	12-WAY / UNKNOWN	
	CA115	16-WAY / BLACK	
PARKING AID SOUNDER, FRONT (INSTRUMENT CLUSTER)	FC8	32-WAY / BLACK	INSTRUMENT CLUSTER
PARKING AID SOUNDER, REAR	CA32	2-WAY / BLACK	PARCEL SHELF
PARKING AID SWITCH (ROOF CONSOLE)	CA250	22-WAY / BLACK	ROOF CONSOLE
REAR LH CENTER SENSOR	BR3	3-WAY / BLACK	REAR BUMPER, LH, CENTER
REAR LH SENSOR	BR2	3-WAY / BLACK	REAR BUMPER, LH
REAR RH CENTER SENSOR	BR4	3-WAY / BLACK	REAR BUMPER, RH CENTER
REAR RH SENSOR	BR5	3-WAY / BLACK	REAR BUMPER, RH

HARNESS IN-LINE CONNECTORS

Connector	Connector Description / Location	Location
BF1	12-WAY / BLACK / FRONT HARNESS TO FRONT BUMPER HARNESS	BEHIND FRONT BUMPER, LH SIDE
BR1	10-WAY / GREY / CABIN HARNESS TO REAR BUMPER HARNESS	BEHIND REAR BUMPER, RH SIDE
FC19	16-WAY / GREEN / CABIN HARNESS TO FASCIA HARNESS	BEHIND INSTRUMENT PANEL, LH SIDE
FH3	16-WAY / BLUE / CABIN HARNESS TO FRONT HARNESS	LH 'A' POST

GROUNDS

Ground	Location
CA50	RH LOWER 'A' POST, BELOW PRIMARY JUNCTION FUSE BOX
CA158	LUGGAGE COMPARTMENT, LH SIDE REAR CORNER
FC38	UNDER CENTER OF INSTRUMENT PANEL, ON TRANSMISSION TUNNEL

FOR CONTROL MODULE PIN-OUT INFORMATION, UNFOLD PAGE TO LEFT, UNFOLD PAGE TO LEFT.

The following abbreviations are used to represent values for Control Module Pin-Out data

I	Input	PG	Power Ground	C	CAN Network	D	Serial and Encoded Data
O	Output	SS	Sensor / Signal Supply V	S	SCP Network	V	Voltage (DC)
B+	Battery Voltage	SG	Sensor / Signal Ground	D2	D2B Network	PWM	Pulse Width Modulated

CAUTION: The information on this data page is furnished to aid the user in understanding circuit operation. THIS INFORMATION SHOULD BE USED FOR REFERENCE ONLY.

NOTE: The values listed are approximately those that can be expected at the control module connector pins with all circuit connections made and all components connected and fitted.

Refer to the front of this book for detailed information and illustrations regarding the location and identification of harnesses, relays, fuses, grounds, control modules and control module pins.

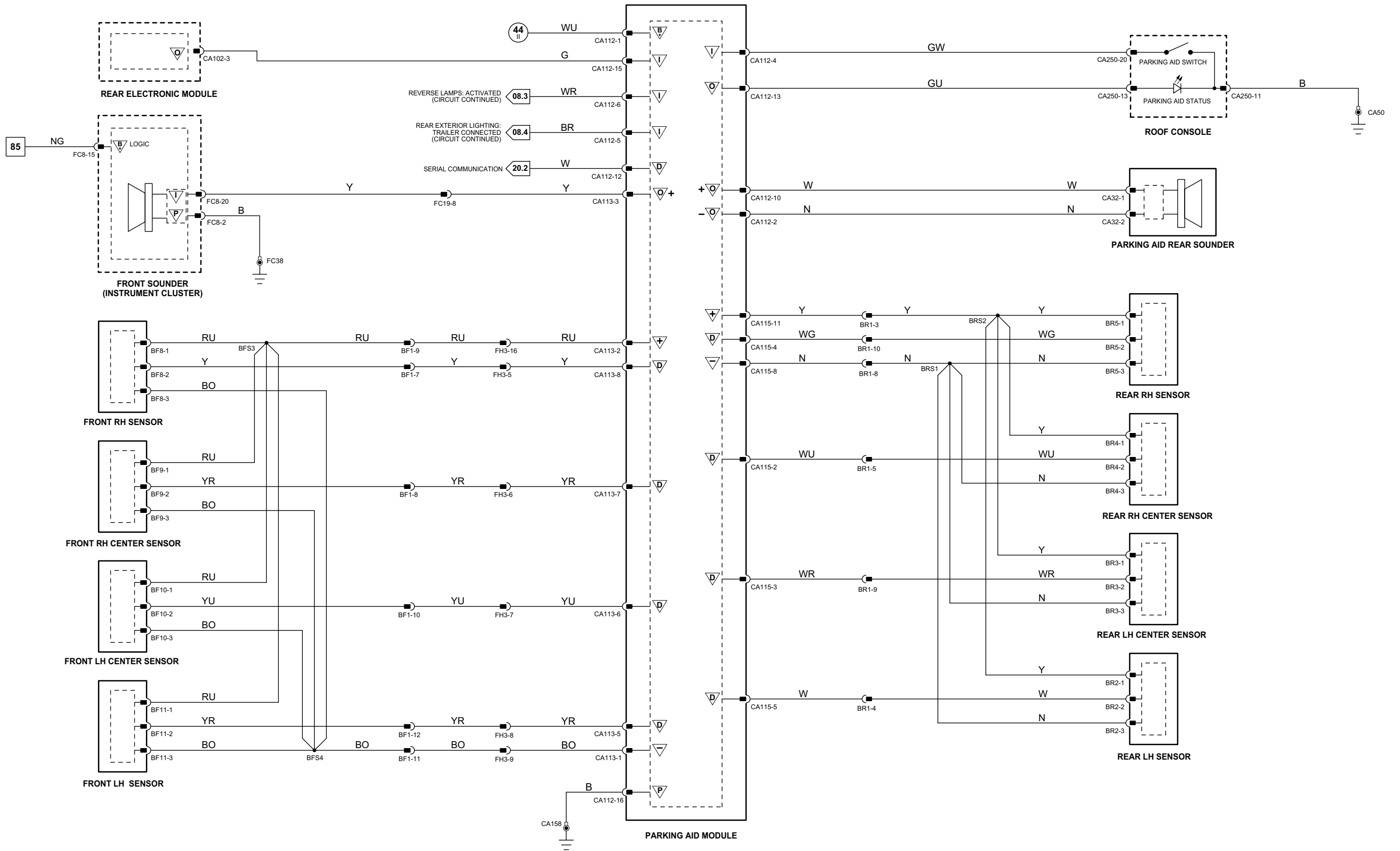

1 → 3
Fig. 01.1

4 → 76
Fig. 01.2

77 → 92
Fig. 01.3

1 → 14
Fig. 01.4

15 → 45
Fig. 01.5

46 → 80
Fig. 01.6

81 → 118
Fig. 01.7

Input
Output

Battery Voltage
Power Ground

Sensor/Signal Supply V
Sensor/Signal Ground

CAN
SCP

D2B Network
Serial and Encoded Data

VARIANT: Parking Aid Vehicles
VIN RANGE: All
DATE OF ISSUE: April 2006

Front Electronic Module

	Pin	Description and Characteristic
S	FH59-1	SCP -
B+	FH59-6	BATTERY POWER SUPPLY (LOGIC): B+
S	FH59-7	SCP +
O	FH59-8	HORN RELAY ACTIVATE: TO ACTIVATE, FEM SWITCHES CIRCUIT TO GROUND
B+	FH60-1	SWITCHED SYSTEM POWER SUPPLY: B+
PG	FH60-11	POWER GROUND: GROUND

Instrument Cluster

	Pin	Description and Characteristic
SG	FC8-32	SIGNAL GROUND: GROUND
I	FC8-9	HORN SWITCH SIGNAL: ACTIVATE = MOMENTARY GROUND
B+	FC8-15	BATTERY POWER SUPPLY (LOGIC): B+
S	FC9-26	SCP -
S	FC9-25	SCP +

Fig. 19.1

COMPONENTS

Component	Connector(s)	Connector Description	Location
ACCESSORY CONNECTOR	CA13	3-WAY / BLACK	ADJACENT TO REAR ELECTRONIC CONTROL MODULE
ACCESSORY RELAY	—	—	PRIMARY JUNCTION FUSE BOX - R1
CIGAR LIGHTER	CA109	3-WAY / BLACK	CENTER CONSOLE
CIGAR LIGHTER / POWER POINT RELAY	—	—	REAR POWER DISTRIBUTION FUSE BOX - R10
ELECTRONIC ROAD PRICING MODULE	SL5	NOT AVAILABLE	INSTRUMENT PANEL
	SL6	NOT AVAILABLE	INSTRUMENT PANEL
FRONT ELECTRONIC MODULE	CA24	26-WAY / NATURAL	LH 'A' POST
	CA31	20-WAY / BLACK	
	FH9	22-WAY / BLACK	
	FH59	12-WAY / BLACK	
	FH60	17-WAY / BLACK	
FRONT POWER DISTRIBUTION FUSE BOX	—	—	ENGINE COMPARTMENT, RH SIDE
HORN RELAY	—	—	FRONT POWER DISTRIBUTION FUSE BOX - R12
HORNS	FH29	2-WAY / BLACK	FORWARD OF RADIATOR
INSTRUMENT CLUSTER	FC8	32-WAY / BLACK	INSTRUMENT CLUSTER
	FC9	32-WAY / BLACK	
POWER POINT	CA237	3-WAY / BROWN	ADJACENT TO CIGAR LIGHTER
PRIMARY JUNCTION FUSE BOX	CA2	26-WAY / BLACK	RH 'A' POST
	CA56	8-WAY / BLACK	
	FC37	26-WAY / BLACK	
	FH7	6-WAY / BLACK	
	FH53	10-WAY / BLACK	
REAR POWER DISTRIBUTION FUSE BOX	—	—	LUGGAGE COMPARTMENT
ROOF CONSOLE	CA250	22-WAY / BLACK	ROOF HEADLINER
STEERING WHEEL HORN SWITCH	SQ2	6-WAY / BLACK	STEERING WHEEL
SUN SHADE MOTOR	CA254	4-WAY / BLACK	LH 'D' POST, ADJACENT TO SEAT BELT RETRACTOR

HARNESS IN-LINE CONNECTORS

Connector	Connector Description / Location	Location
FC10	14-WAY / GREEN / FASCIA HARNESS TO FRONT HARNESS	BEHIND INSTRUMENT PANEL, RH SIDE
FC117	10-WAY / BLACK / STEERING WHEEL CASSETTE	STEERING COLUMN
SL3	10-WAY / GREY / FASCIA HARNESS TO SOLAR SENSOR LINK	BEHIND INSTRUMENT PANEL, RH SIDE

GROUNDS

Ground	Location
CA21	LUGGAGE COMPARTMENT, LH SIDE AFT OF WHEEL ARCH
CA50	RH LOWER 'A' POST, BELOW PRIMARY JUNCTION FUSE BOX
CA141	UNDER LH FRONT SEAT
CA154	UNDER RH FRONT SEAT
CA156	LUGGAGE COMPARTMENT, RH SIDE
FC38	UNDER CENTER OF INSTRUMENT PANEL, ON TRANSMISSION TUNNEL
FH42	ENGINE COMPARTMENT, BEHIND RH HEADLAMP
FH77	LH LOWER 'A' POST, ADJACENT TO THE FRONT ELECTRONIC MODULE (FORWARD OF CA30)

FOR CONTROL MODULE PIN-OUT INFORMATION, UNFOLD PAGE TO LEFT.

The following abbreviations are used to represent values for Control Module Pin-Out data

I	Input	PG	Power Ground	C	CAN Network	D	Serial and Encoded Data
O	Output	SS	Sensor / Signal Supply V	S	SCP Network	V	Voltage (DC)
B+	Battery Voltage	SG	Sensor / Signal Ground	D2	D2B Network	PWM	Pulse Width Modulated

CAUTION: The information on this data page is furnished to aid the user in understanding circuit operation. THIS INFORMATION SHOULD BE USED FOR REFERENCE ONLY.

NOTE: The values listed are approximately those that can be expected at the control module connector pins with all circuit connections made and all components connected and fitted.

Refer to the front of this book for detailed information and illustrations regarding the location and identification of harnesses, relays, fuses, grounds, control modules and control module pins.

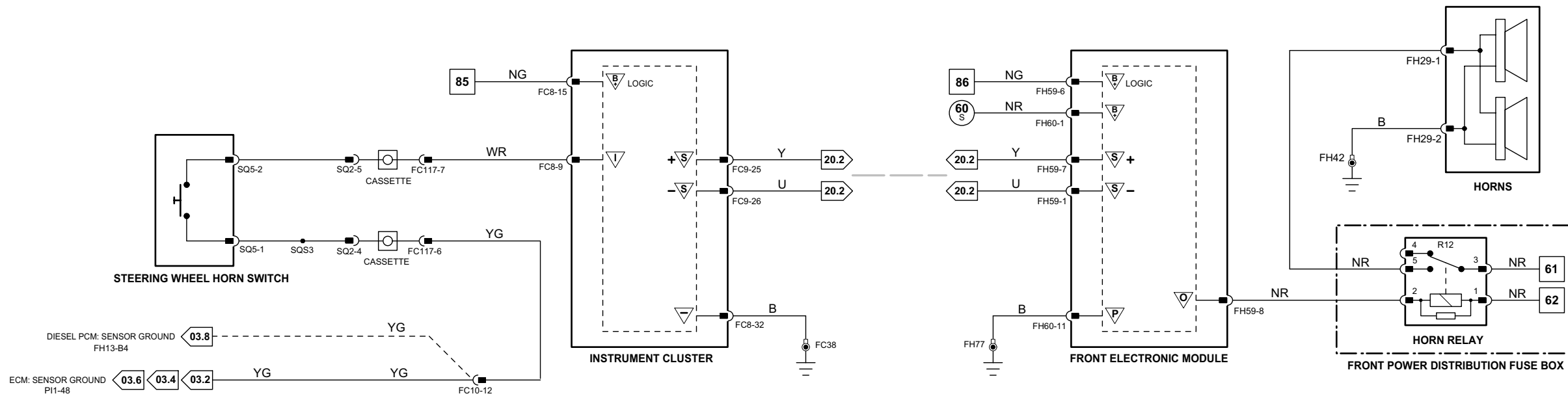

HORNS

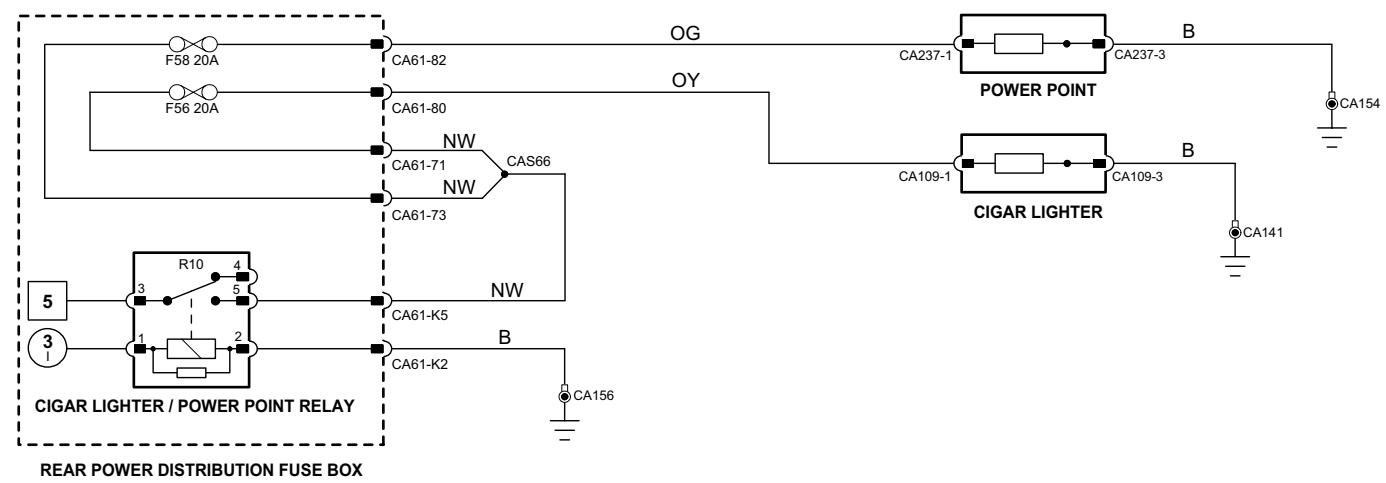

CIGAR LIGHTER; POWER POINT

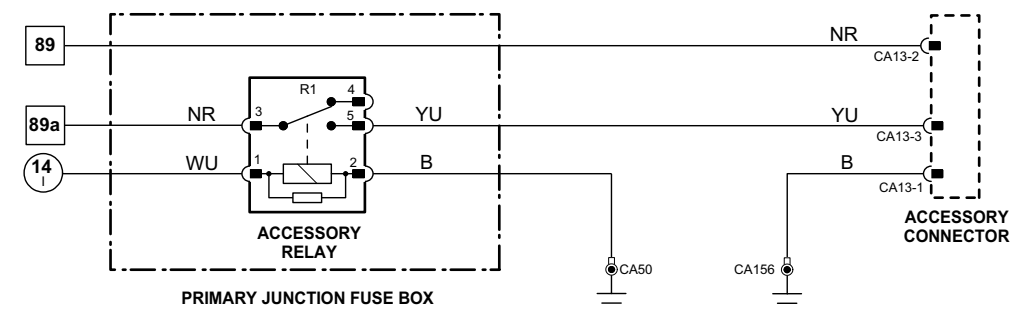

ACCESSORY CONNECTOR

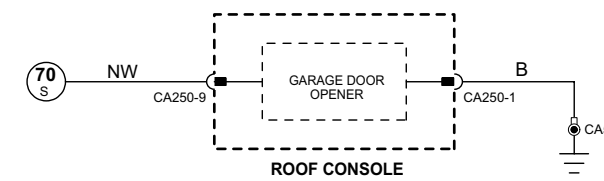

GARAGE DOOR OPENER

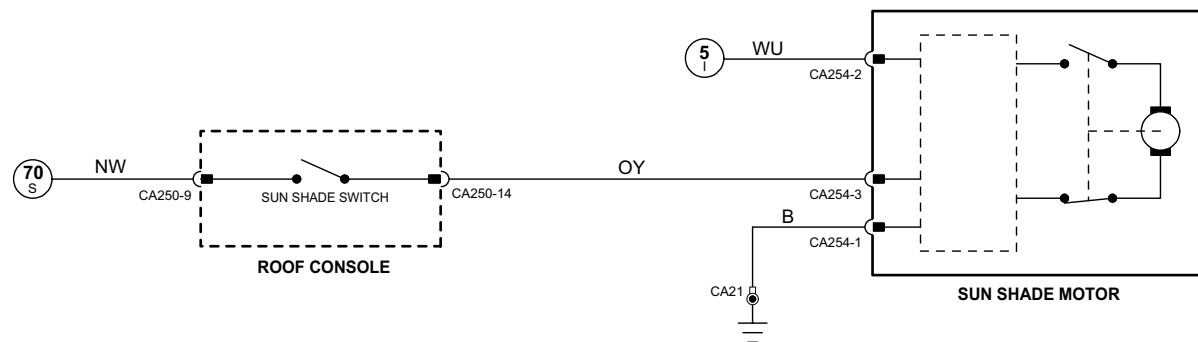

SUN SHADE

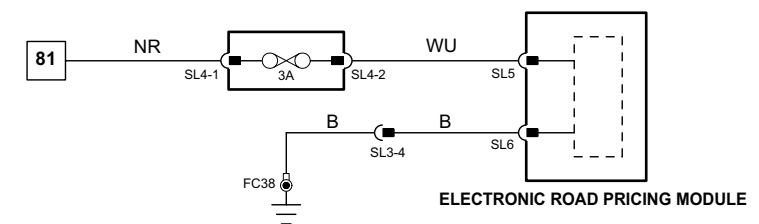

ELECTRONIC ROAD PRICING

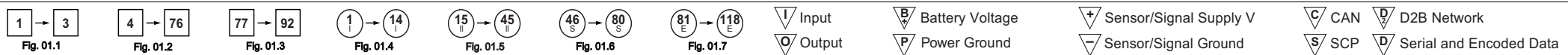

VARIANT: All Vehicles
VIN RANGE: All
DATE OF ISSUE: April 2006

Fig. 20.1**COMPONENTS**

Component	Connector(s)	Connector Description	Location
AIR CONDITIONING CONTROL MODULE – PANEL	FC27	26-WAY / GREY	CENTER CONSOLE
	FC28	22-WAY / GREY	
AIR CONDITIONING CONTROL MODULE – REMOTE	FC40	26-WAY / GREY	BEHIND INSTRUMENT PANEL, PASSENGER SIDE
	FC41	22-WAY / GREY	
DATA LINK CONNECTOR	FC1	DATA LINK CONNECTOR	BELOW INSTRUMENT PANEL, LH SIDE
DYNAMIC STABILITY CONTROL MODULE	FH103	47-WAY / BLACK	ENGINE COMPARTMENT, RH FRONT
ENGINE CONTROL MODULE	FH300	58-WAY / BLACK	FRONT BULKHEAD, PASSENGER SIDE
	PI300	96-WAY / BLACK	FRONT BULKHEAD, PASSENGER SIDE
FUEL-FIRED AUXILIARY HEATER MODULE (DIESEL 2.7V6)	FH24	8-WAY / BLACK	BELOW LH HEADLAMP ASSEMBLY
	FH25	2-WAY / BLACK	
HEADLAMP LEVELING CONTROL MODULE	FH12	26-WAY / BLACK	RH 'A' POST, ABOVE PRIMARY JUNCTION FUSE BOX
INSTRUMENT CLUSTER	FC8	32-WAY / BLACK	INSTRUMENT CLUSTER
	FC9	32-WAY / BLACK	
J-GATE MODULE	CA245	16-WAY / BLACK	J-GATE ASSEMBLY
PARKING BRAKE MODULE	CA265	14-WAY / GREY	LUGGAGE COMPARTMENT, RH REAR
	CA266	24-WAY / BLACK	
POWERTRAIN CONTROL MODULE (DIESEL 2.7V6)	C98	48-WAY / BROWN	FRONT BULKHEAD, PASSENGER SIDE
	C99	48-WAY / GREY	
	FH13	48-WAY / BLACK	
SPEED CONTROL MODULE	FC6	30-WAY YELLOW	BEHIND INSTRUMENT PANEL, DRIVER SIDE
TRANSMISSION CONTROL MODULE	GB2	16-WAY / BLACK	TRANSMISSION CONTROL VALVE ASSEMBLY

HARNES IN-LINE CONNECTORS

Connector	Connector Description / Location	Location
FC39	10-WAY / GREY / CABIN HARNESS TO FASCIA HARNESS	BEHIND INSTRUMENT PANEL, RH SIDE
FH1	22-WAY / DARK GREY / CABIN HARNESS TO FRONT HARNESS	RH 'A' POST, LOWER
GB1	16-WAY / GREY / ENGINE HARNESS TO TRANSMISSION HARNESS	ADJACENT TO TRANSMISSION BELL HOUSING
PI41	42-WAY / BLACK / ENGINE HARNESS TO VEHICLE HARNESSES	ENGINE COMPARTMENT, BULKHEAD, PASSENGER SIDE

GROUNDS

Ground	Location
FC38	UNDER CENTER OF INSTRUMENT PANEL, ON TRANSMISSION TUNNEL

Refer to the front of this book for detailed information and illustrations regarding the location and identification of harnesses, relays, fuses, grounds, control modules and control module pins.

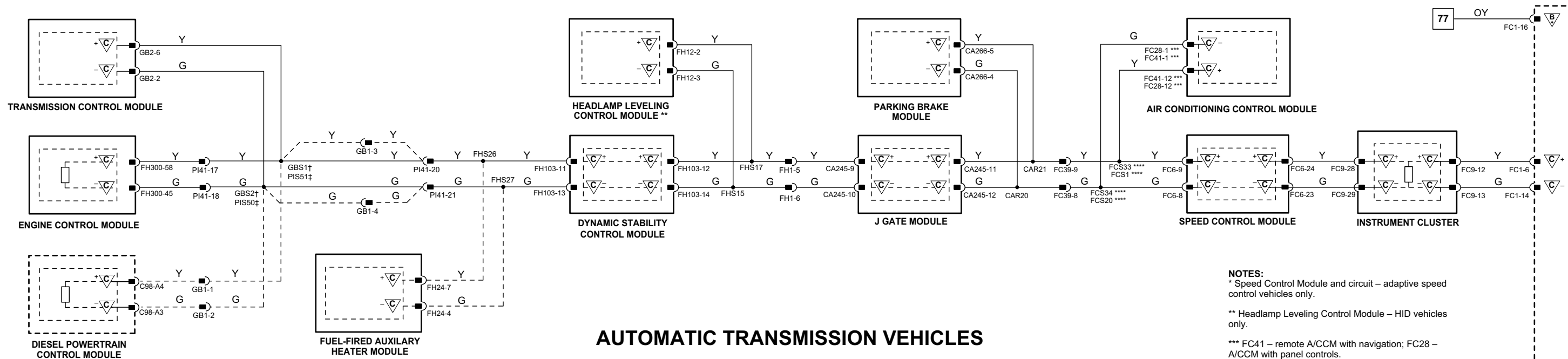

AUTOMATIC TRANSMISSION VEHICLES

NOTES:
 * Speed Control Module and circuit – adaptive speed control vehicles only.
 ** Headlamp Leveling Control Module – HID vehicles only.
 *** FC41 – remote A/CCM with navigation; FC28 – A/CCM with panel controls.
 **** FCS33 and FCS34 – A/CCM with panel controls; FCS1 and FCS20 – remote A/CCM with navigation.
 † GBS1 and GBS2 - Diesel.
 ‡ PIS50 and PIS51 - Gasoline.

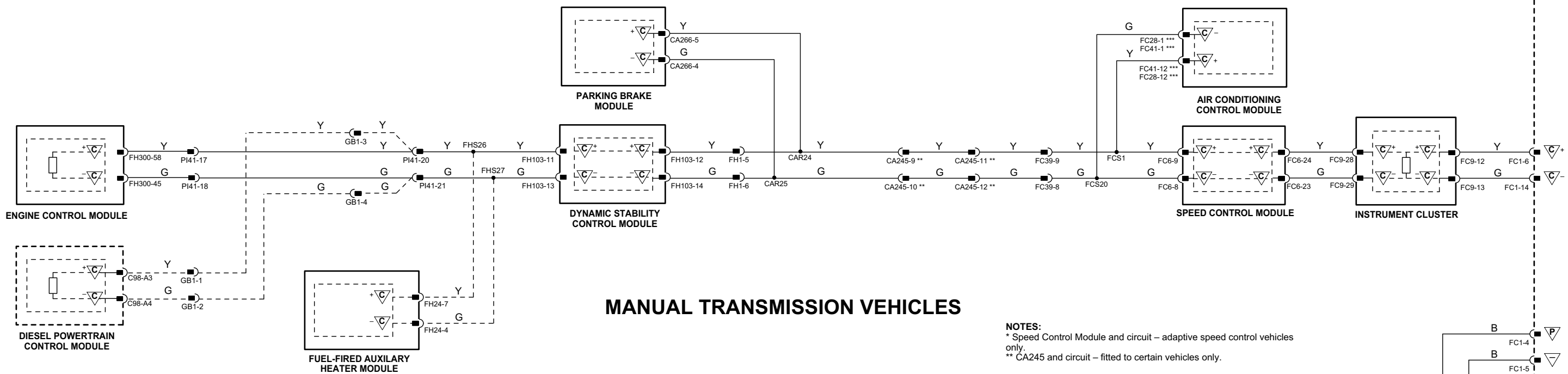

MANUAL TRANSMISSION VEHICLES

NOTES:
 * Speed Control Module and circuit – adaptive speed control vehicles only.
 ** CA245 and circuit – fitted to certain vehicles only.

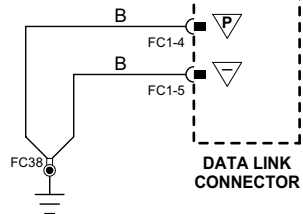

1 → 3 Fig. 01.1	4 → 76 Fig. 01.2	77 → 92 Fig. 01.3	1 → 14 Fig. 01.4	15 → 45 Fig. 01.5	46 → 80 Fig. 01.8	81 → 118 Fig. 01.7	Input	Battery Voltage	Sensor/Signal Supply V	CAN	D2B Network
							Output	Power Ground	Sensor/Signal Ground	SCP	Serial and Encoded Data

VARIANT: All Vehicles
VIN RANGE: All
DATE OF ISSUE: April 2006

Fig. 20.2**COMPONENTS**

Component	Connector(s)	Connector Description	Location
ADAPTIVE DAMPING CONTROL MODULE	CA11	16-WAY / BLUE	LUGGAGE COMPARTMENT, REAR
	CA12	16-WAY / GREY	
AUDIO UNIT	FC94	20-WAY / BLACK	CENTER CONSOLE
	FC96	ANTENNA CONNECTOR	
	FC108	FIBER OPTIC CONNECTOR	
DATA LINK CONNECTOR	FC1	DATA LINK CONNECTOR	BELOW INSTRUMENT PANEL, LH SIDE
DRIVER DOOR MODULE	CA85	12-WAY / BLACK	DRIVER DOOR
	DD4	26-WAY / NATURAL	
	DT2	20-WAY / BLACK	
DRIVER SEAT MODULE	DM33	26-WAY / BLACK	UNDER DRIVER SEAT
	DM34	22-WAY / BLACK	
	DM35	6-WAY / BLACK	
	DM36	4-WAY / BLACK	
	DM37	4-WAY / BLACK	
	DM38	6-WAY / BLACK	
FRONT ELECTRONIC MODULE	CA24	26-WAY / NATURAL	LH 'A' POST
	CA31	20-WAY / BLACK	
	FH9	22-WAY / BLACK	
	FH59	12-WAY / BLACK	
	FH60	17-WAY / BLACK	
HEADLAMP LEVELING CONTROL MODULE	FH12	26-WAY / BLACK	RH 'A' POST, ABOVE PRIMARY JUNCTION FUSE BOX
INSTRUMENT CLUSTER	FC8	32-WAY / BLACK	INSTRUMENT CLUSTER
	FC9	32-WAY / BLACK	
NAVIGATION CONTROL MODULE	CA176	2-WAY / GREY	LUGGAGE COMPARTMENT, LH REAR
	CA257	26-WAY / NATURAL	
	CA258	20-WAY / BLACK	
	CA259	12-WAY / BLACK	
	RA5	FIBER OPTIC CONNECTOR	
PARKING AID MODULE	CA112	26-WAY / BLACK	LUGGAGE COMPARTMENT, LH REAR
REAR ELECTRONIC MODULE	CA63	17-WAY / BLACK	LUGGAGE COMPARTMENT, RH REAR
	CA100	12-WAY / BLACK	
	CA101	20-WAY / BLACK	
	CA102	22-WAY / BLACK	
	CA103	26-WAY / NATURAL	
RESTRAINTS CONTROL MODULE	CA114	24-WAY / BLACK	TRANSMISSION TUNNEL, UNDER CENTER CONSOLE
	CA232	40-WAY / BLACK	
ROOF CONSOLE	CA250	22-WAY / BLACK	ROOF HEADLINER
STEERING COLUMN LOCK MODULE	FC59	4-WAY / BLACK	ADJACENT TO STEERING COLUMN LOCK

HARNES IN-LINE CONNECTORS

Connector	Connector Description / Location	Location
DM23	20-WAY / BLACK / CABIN HARNESS TO DRIVER SEAT HARNESS	UNDER DRIVER SEAT
FC17	16-WAY / BLUE / CABIN HARNESS TO FASCIA HARNESS	BEHIND INSTRUMENT PANEL, PASSENGER SIDE
FC33	16-WAY / GREEN / CABIN HARNESS TO FASCIA HARNESS	BEHIND INSTRUMENT PANEL, RH SIDE
FH6	16-WAY GREEN / CABIN HARNESS TO FRONT HARNESS	LH 'A' POST, ADJACENT TO FEM

GROUNDS

Ground	Location
FC38	UNDER CENTER OF INSTRUMENT PANEL, ON TRANSMISSION TUNNEL

Refer to the front of this book for detailed information and illustrations regarding the location and identification of harnesses, relays, fuses, grounds, control modules and control module pins.

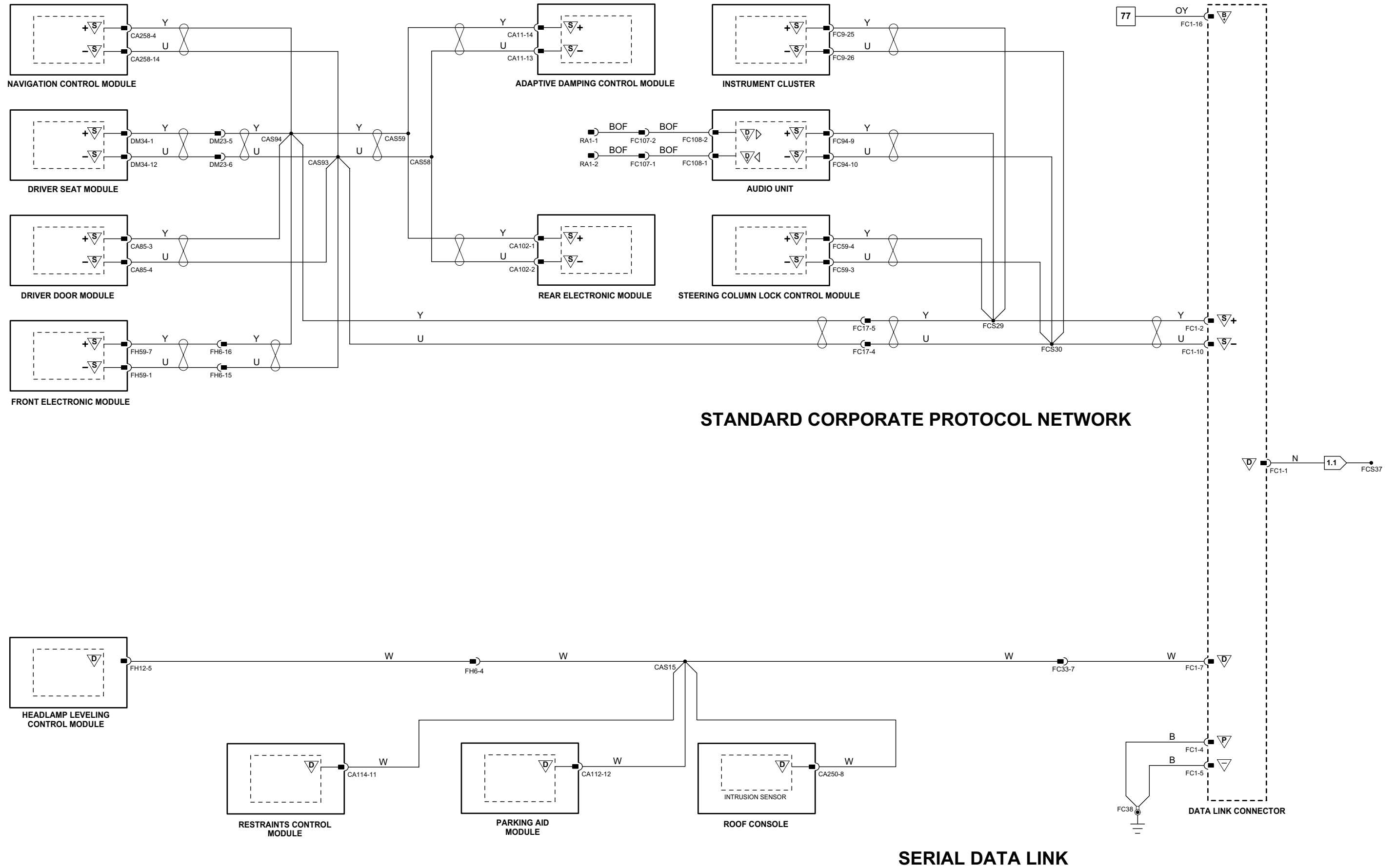

1 → 3
Fig. 01.1

4 → 76
Fig. 01.2

77 → 92
Fig. 01.3

1 → 14
Fig. 01.4

15 → 45
Fig. 01.5

46 → 80
Fig. 01.8

81 → 118
Fig. 01.7

Input
Output

B Battery Voltage
P Power Ground

∇ Sensor/Signal Supply V
∇ Sensor/Signal Ground

∇ CAN
∇ SCP

∇ D2B Network
∇ Serial and Encoded Data

VARIANT: All Vehicles
VIN RANGE: All
DATE OF ISSUE: April 2006

Fig. 20.3**COMPONENTS**

Component	Connector(s)	Connector Description	Location
AUDIO UNIT	FC94	20-WAY / BLACK	CENTER CONSOLE
	FC96	ANTENNA CONNECTOR	
	FC108	FIBER OPTIC CONNECTOR	
CD AUTOCHANGER	CA267	3-WAY / BLACK	LUGGAGE COMPARTMENT, LH REAR
	RA2	FIBER OPTIC CONNECTOR	
CELLULAR PHONE CONTROL MODULE	CA209	2-WAY / BLACK	LUGGAGE COMPARTMENT, LH REAR
	CA210	2-WAY / BLACK	
	CA211	2-WAY / BLACK	
	CA261	32-WAY / BLACK	
	RA3	FIBER OPTIC CONNECTOR	
	CA176	2-WAY / GREY	
NAVIGATION CONTROL MODULE	CA257	26-WAY / NATURAL	LUGGAGE COMPARTMENT, LH REAR
	CA258	20-WAY / BLACK	
	CA259	12-WAY / BLACK	
	RA5	FIBER OPTIC CONNECTOR	
	CA263	POWER AMPLIFIER CONNECTOR	
	CA264	POWER AMPLIFIER CONNECTOR	
POWER AMPLIFIER	RA6	FIBER OPTIC CONNECTOR	LUGGAGE COMPARTMENT, LH REAR
	CA300	22-WAY / GREY	
VOICE ACTIVATION MODULE	CA300	22-WAY / GREY	LUGGAGE COMPARTMENT, LH REAR
	RA4	FIBER OPTIC CONNECTOR	

HARNESS IN-LINE CONNECTORS

Connector	Connector Description / Location	Location
FC23	10-WAY / GREY / CABIN HARNESS TO FASCIA HARNESS	BEHIND INSTRUMENT PANEL, LH SIDE
FC107	2-WAY / BLACK / FIBER OPTIC IN-LINE CONNECTOR	UNDER CENTER CONSOLE
RA1	2-WAY / FIBER OPTIC / FIBER OPTIC IN-LINE CONNECTOR	LUGGAGE COMPARTMENT, LH SIDE
RA10	2-WAY / FIBER OPTIC / FIBER OPTIC IN-LINE CONNECTOR	LUGGAGE COMPARTMENT, LH SIDE

Refer to the front of this book for detailed information and illustrations regarding the location and identification of harnesses, relays, fuses, grounds, control modules and control module pins.

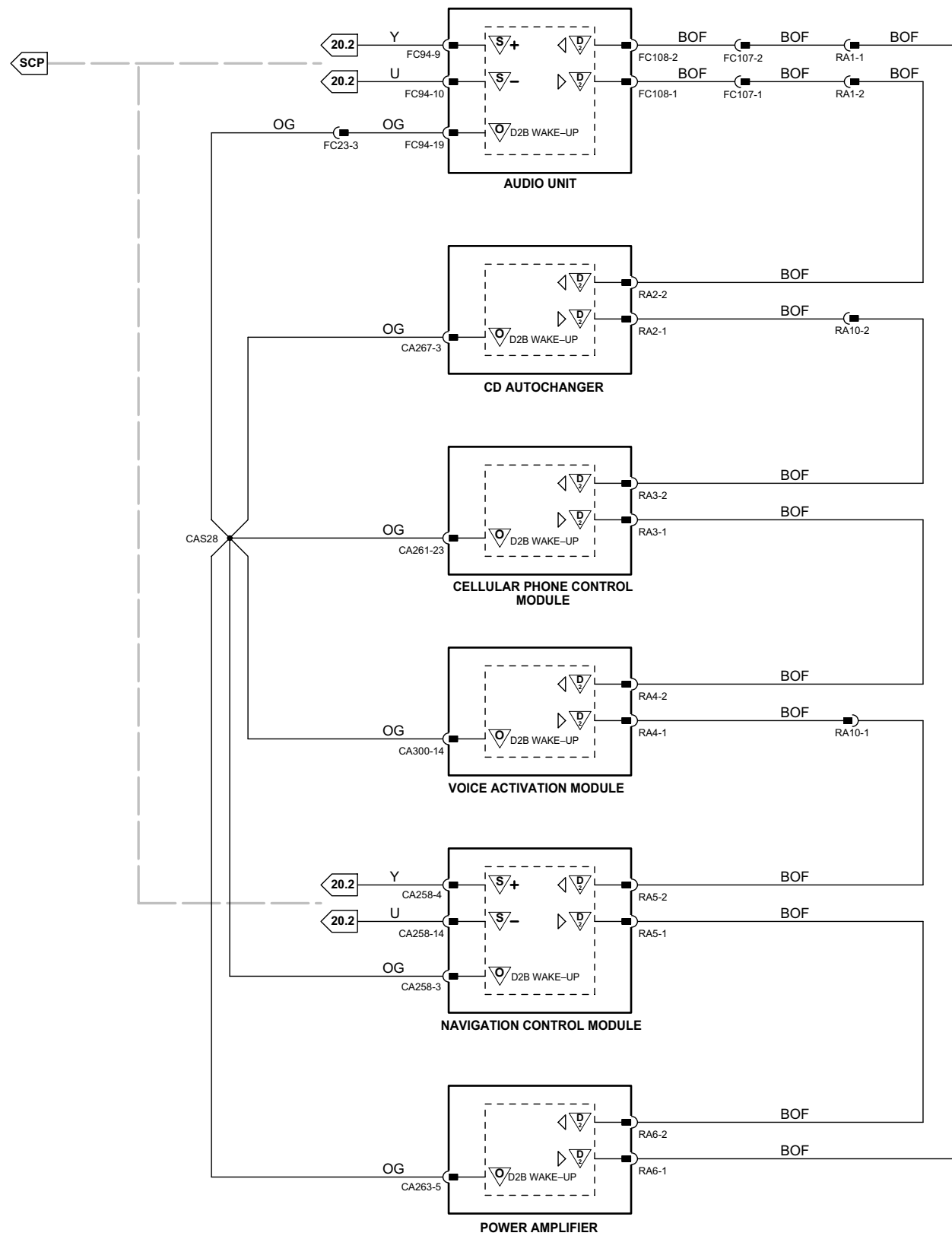

D2B NETWORK WAKE-UP; 6-MODULE NETWORK

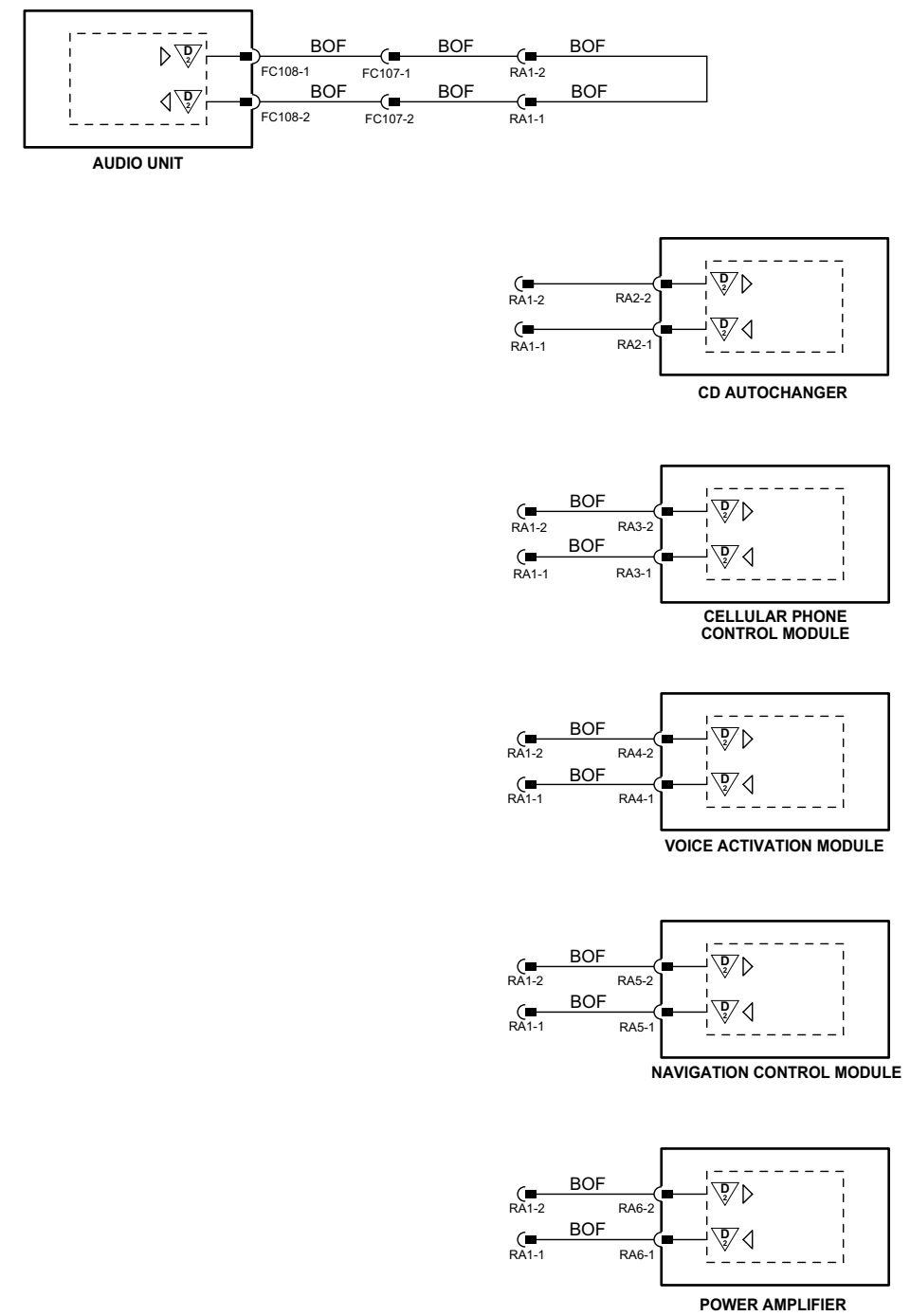

2-MODULE NETWORKS

NOTES:
 Figures 20.3, 20.4, 20.5 and 20.6 show all possible combinations of D2B networks.
 D2B network diagnostics via SCP – Refer to Fig. 20.2.

Fig. 20.4**COMPONENTS**

Component	Connector(s)	Connector Description	Location
AUDIO UNIT	FC94	20-WAY / BLACK	CENTER CONSOLE
	FC96	ANTENNA CONNECTOR	
CD AUTOCHANGER	FC108	FIBER OPTIC CONNECTOR	LUGGAGE COMPARTMENT, LH REAR
	CA267	3-WAY / BLACK	
CELLULAR PHONE CONTROL MODULE	RA2	FIBER OPTIC CONNECTOR	LUGGAGE COMPARTMENT, LH REAR
	CA209	2-WAY / BLACK	
	CA210	2-WAY / BLACK	
	CA211	2-WAY / BLACK	
	CA261	32-WAY / BLACK	
NAVIGATION CONTROL MODULE	RA3	FIBER OPTIC CONNECTOR	LUGGAGE COMPARTMENT, LH REAR
	CA176	2-WAY / GREY	
	CA257	26-WAY / NATURAL	
	CA258	20-WAY / BLACK	
	CA259	12-WAY / BLACK	
POWER AMPLIFIER	RA5	FIBER OPTIC CONNECTOR	LUGGAGE COMPARTMENT, LH REAR
	CA263	POWER AMPLIFIER CONNECTOR	
	CA264	POWER AMPLIFIER CONNECTOR	
VOICE ACTIVATION MODULE	RA6	FIBER OPTIC CONNECTOR	LUGGAGE COMPARTMENT, LH REAR
	CA300	22-WAY / GREY	
	RA4	FIBER OPTIC CONNECTOR	

HARNESS IN-LINE CONNECTORS

Connector	Connector Description / Location	Location
FC107	2-WAY / BLACK / FIBER OPTIC IN-LINE CONNECTOR	UNDER CENTER CONSOLE
RA1	2-WAY / FIBER OPTIC / FIBER OPTIC IN-LINE CONNECTOR	LUGGAGE COMPARTMENT, LH SIDE
RA10	2-WAY / FIBER OPTIC / FIBER OPTIC IN-LINE CONNECTOR	LUGGAGE COMPARTMENT, LH SIDE

Refer to the front of this book for detailed information and illustrations regarding the location and identification of harnesses, relays, fuses, grounds, control modules and control module pins.

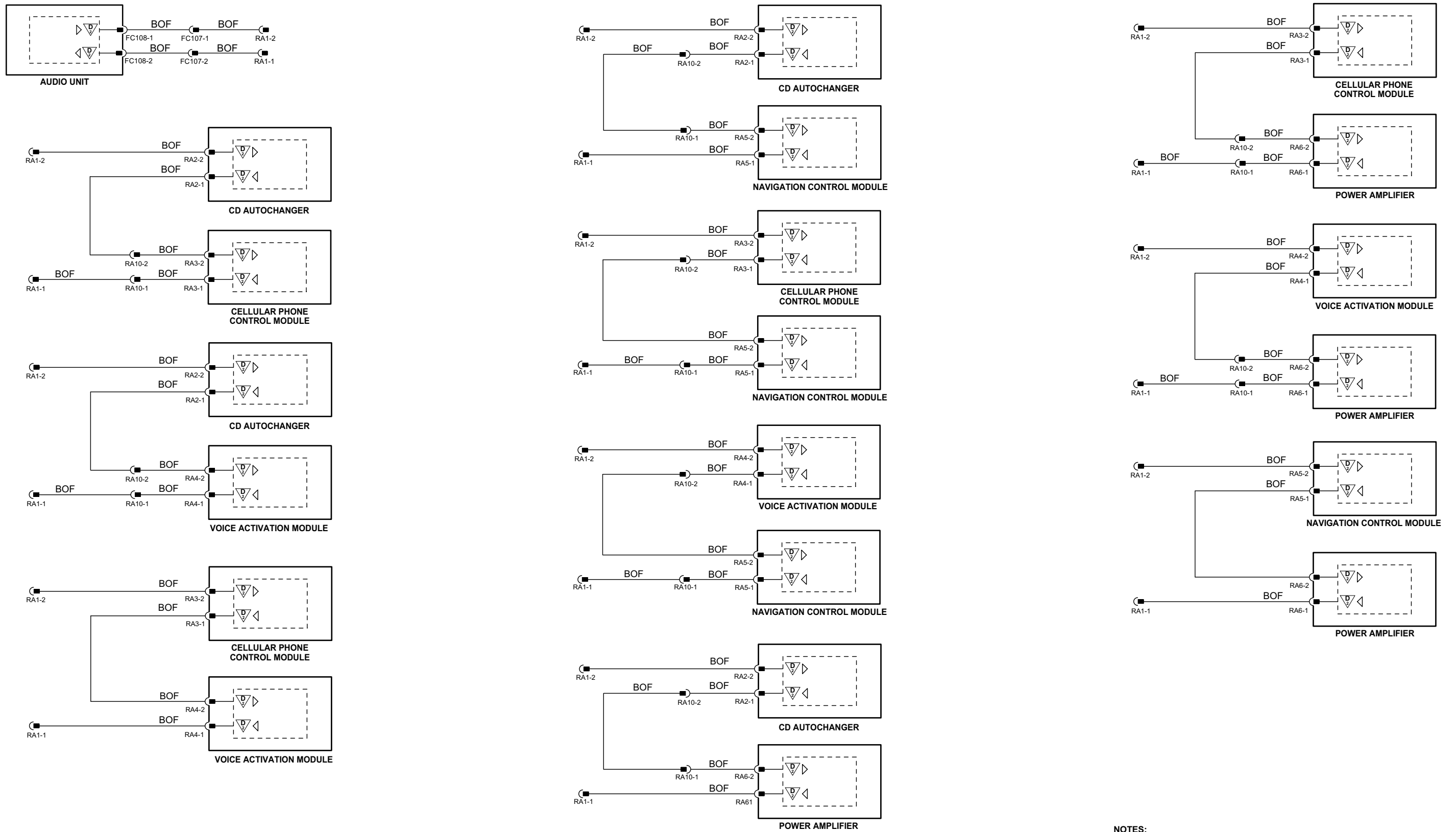

3-MODULE NETWORKS

NOTES:

Figures 20.3, 20.4, 20.5 and 20.6 show all possible combinations of D2B networks. D2B network diagnostics via SCP - Refer to Fig. 20.2.



VARIANT: All Vehicles
VIN RANGE: All
DATE OF ISSUE: April 2006

Fig. 20.5**COMPONENTS**

Component	Connector(s)	Connector Description	Location
AUDIO UNIT	FC94	20-WAY / BLACK	CENTER CONSOLE
	FC96	ANTENNA CONNECTOR	
CD AUTOCHANGER	FC108	FIBER OPTIC CONNECTOR	LUGGAGE COMPARTMENT, LH REAR
	CA267	3-WAY / BLACK	
CELLULAR PHONE CONTROL MODULE	RA2	FIBER OPTIC CONNECTOR	LUGGAGE COMPARTMENT, LH REAR
	CA209	2-WAY / BLACK	
	CA210	2-WAY / BLACK	
	CA211	2-WAY / BLACK	
	CA261	32-WAY / BLACK	
NAVIGATION CONTROL MODULE	RA3	FIBER OPTIC CONNECTOR	LUGGAGE COMPARTMENT, LH REAR
	CA176	2-WAY / GREY	
	CA257	26-WAY / NATURAL	
	CA258	20-WAY / BLACK	
	CA259	12-WAY / BLACK	
POWER AMPLIFIER	RA5	FIBER OPTIC CONNECTOR	LUGGAGE COMPARTMENT, LH REAR
	CA263	POWER AMPLIFIER CONNECTOR	
	CA264	POWER AMPLIFIER CONNECTOR	
VOICE ACTIVATION MODULE	RA6	FIBER OPTIC CONNECTOR	LUGGAGE COMPARTMENT, LH REAR
	CA300	22-WAY / GREY	
	RA4	FIBER OPTIC CONNECTOR	

HARNESS IN-LINE CONNECTORS

Connector	Connector Description / Location	Location
FC107	2-WAY / BLACK / FIBER OPTIC IN-LINE CONNECTOR	UNDER CENTER CONSOLE
RA1	2-WAY / FIBER OPTIC / FIBER OPTIC IN-LINE CONNECTOR	LUGGAGE COMPARTMENT, LH SIDE
RA10	2-WAY / FIBER OPTIC / FIBER OPTIC IN-LINE CONNECTOR	LUGGAGE COMPARTMENT, LH SIDE

Refer to the front of this book for detailed information and illustrations regarding the location and identification of harnesses, relays, fuses, grounds, control modules and control module pins.

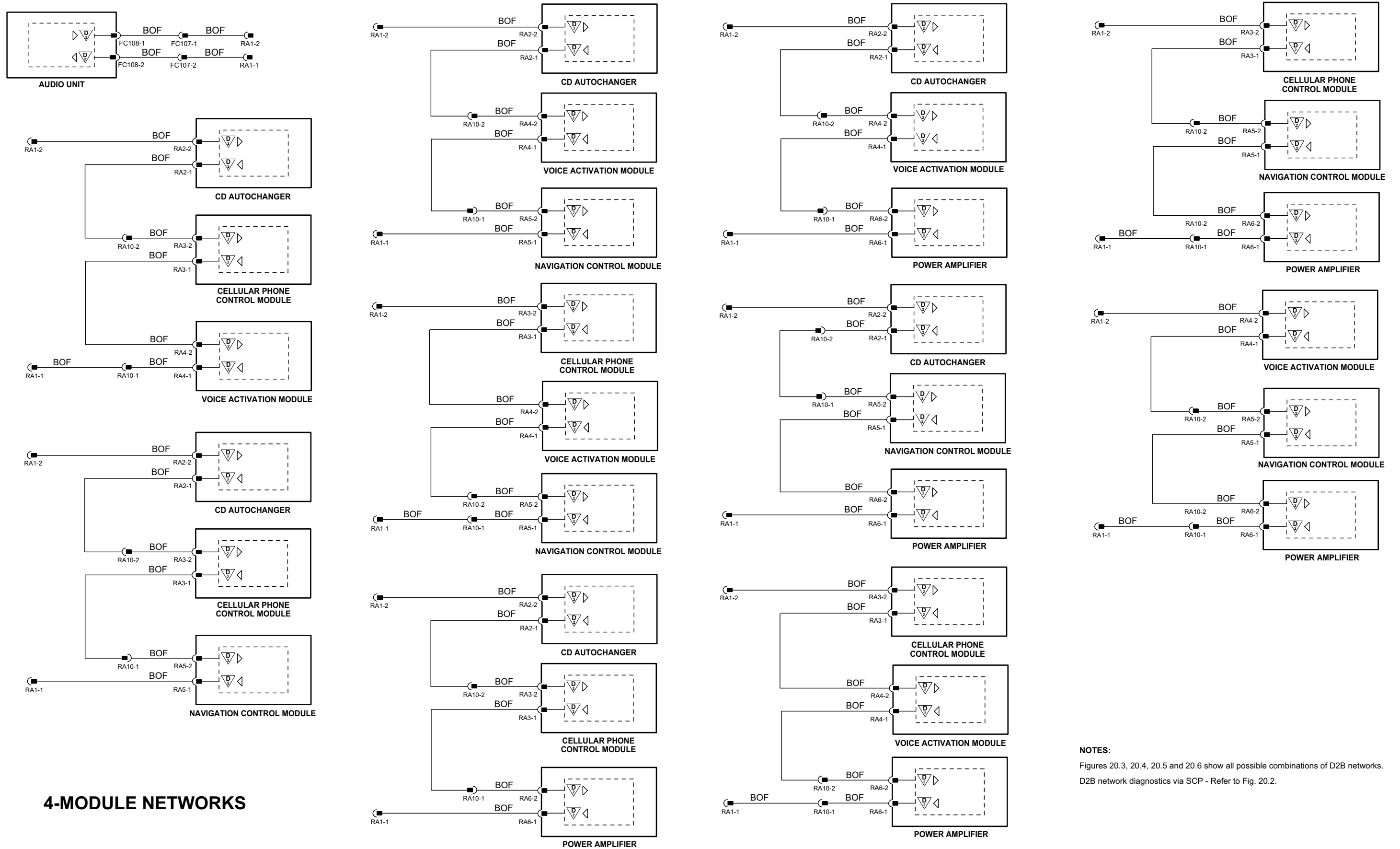

4-MODULE NETWORKS

NOTES:
 Figures 20.3, 20.4, 20.5 and 20.6 show all possible combinations of D2B networks.
 D2B network diagnostics via SCP - Refer to Fig. 20.2.

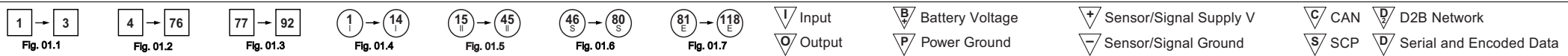

VARIANT: All Vehicles
VIN RANGE: All
DATE OF ISSUE: April 2006

Fig. 20.6**COMPONENTS**

Component	Connector(s)	Connector Description	Location
AUDIO UNIT	FC94	20-WAY / BLACK	CENTER CONSOLE
	FC96	ANTENNA CONNECTOR	
	FC108	FIBER OPTIC CONNECTOR	
CD AUTOCHANGER	CA267	3-WAY / BLACK	LUGGAGE COMPARTMENT, LH REAR
	RA2	FIBER OPTIC CONNECTOR	
CELLULAR PHONE CONTROL MODULE	CA209	2-WAY / BLACK	LUGGAGE COMPARTMENT, LH REAR
	CA210	2-WAY / BLACK	
	CA211	2-WAY / BLACK	
	CA261	32-WAY / BLACK	
	RA3	FIBER OPTIC CONNECTOR	
NAVIGATION CONTROL MODULE	CA176	2-WAY / GREY	LUGGAGE COMPARTMENT, LH REAR
	CA257	26-WAY / NATURAL	
	CA258	20-WAY / BLACK	
	CA259	12-WAY / BLACK	
	RA5	FIBER OPTIC CONNECTOR	
POWER AMPLIFIER	CA263	POWER AMPLIFIER CONNECTOR	LUGGAGE COMPARTMENT, LH REAR
	CA264	POWER AMPLIFIER CONNECTOR	
	RA6	FIBER OPTIC CONNECTOR	
VOICE ACTIVATION MODULE	CA300	22-WAY / GREY	LUGGAGE COMPARTMENT, LH REAR
	RA4	FIBER OPTIC CONNECTOR	

HARNESS IN-LINE CONNECTORS

Connector	Connector Description / Location	Location
FC107	2-WAY / BLACK / FIBER OPTIC IN-LINE CONNECTOR	UNDER CENTER CONSOLE
RA1	2-WAY / FIBER OPTIC / FIBER OPTIC IN-LINE CONNECTOR	LUGGAGE COMPARTMENT, LH SIDE
RA10	2-WAY / FIBER OPTIC / FIBER OPTIC IN-LINE CONNECTOR	LUGGAGE COMPARTMENT, LH SIDE

Refer to the front of this book for detailed information and illustrations regarding the location and identification of harnesses, relays, fuses, grounds, control modules and control module pins.

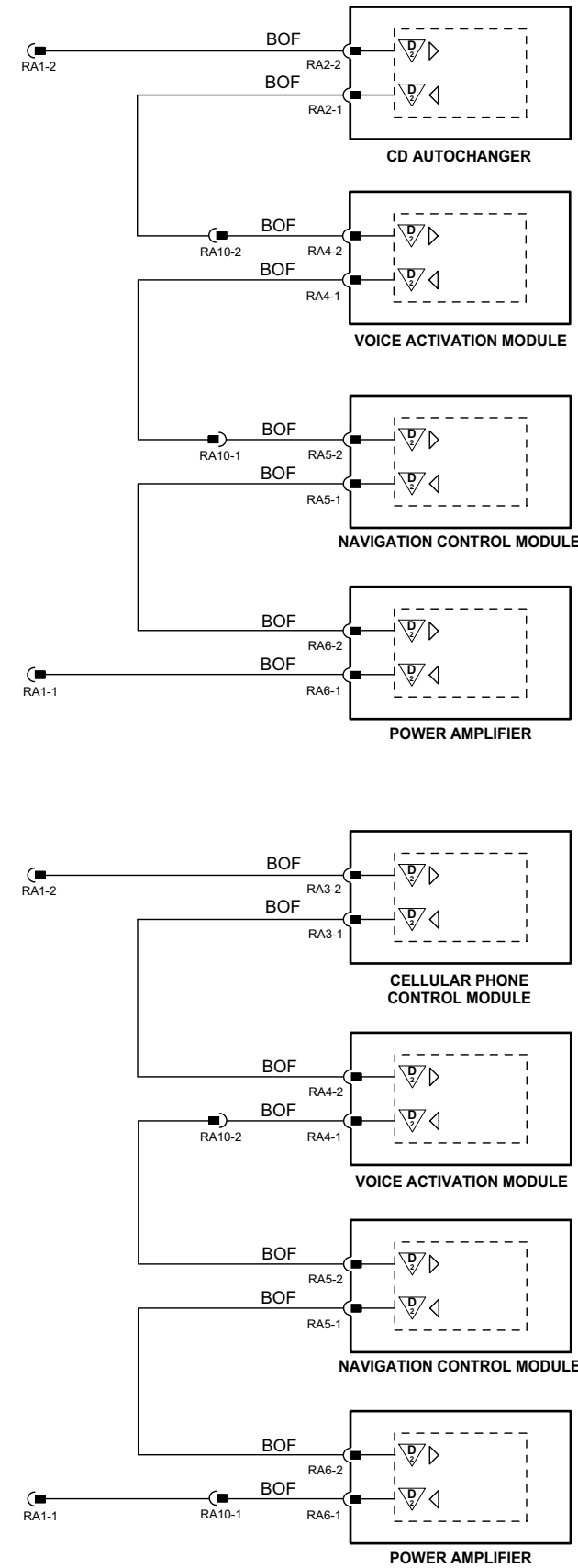
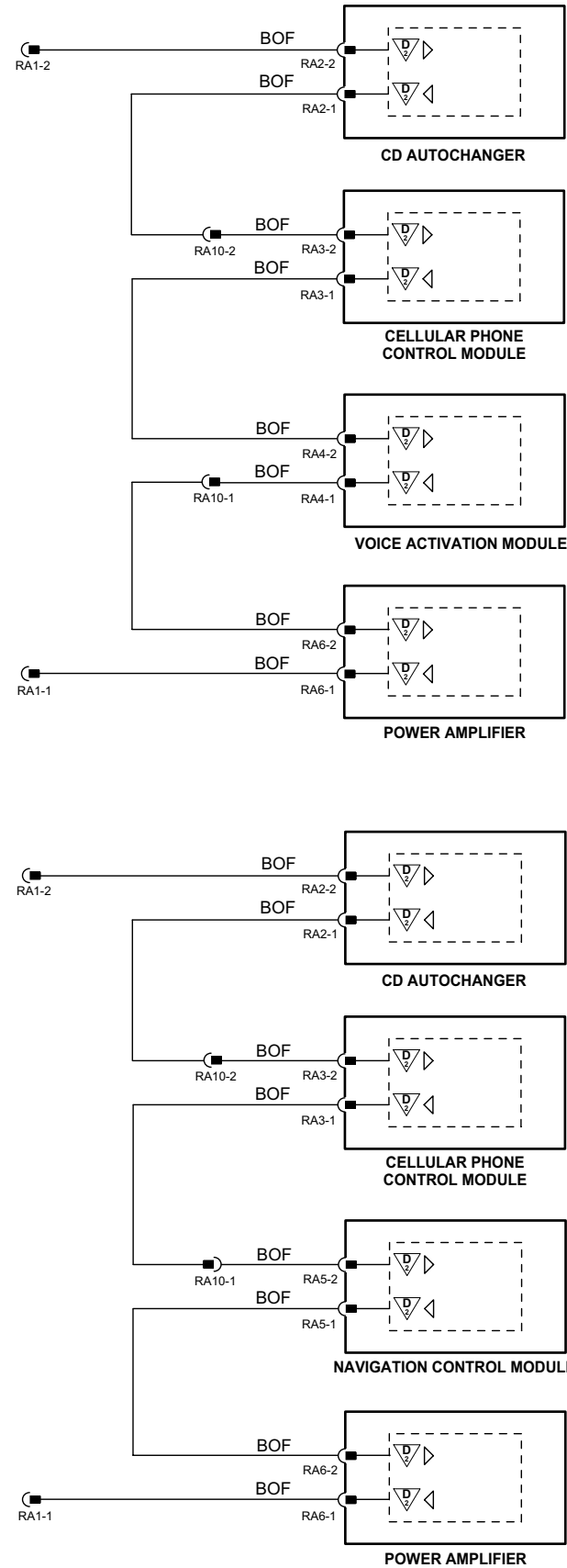
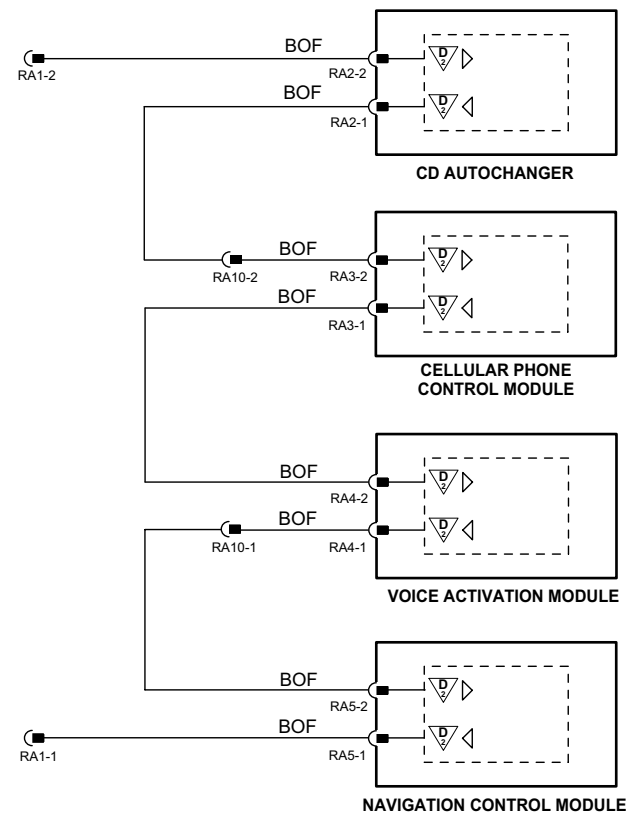
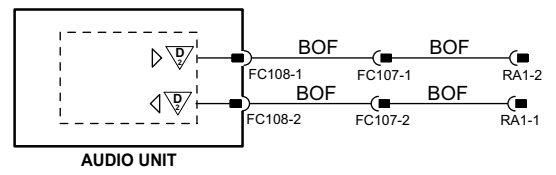

NOTES:
 Figures 20.3, 20.4, 20.5 and 20.6 show all possible combinations of D2B networks.
 D2B network diagnostics via SCP - Refer to Fig. 20.2.

A		BLOWER MOTOR	Fig. 06.1
ACCESSORY CONNECTOR	Fig. 19.1	BLOWER MOTOR RELAY	Fig. 06.1
ACCESSORY RELAY	Fig. 19.1	BRAKE CANCEL SWITCH	Fig. 03.2
ACT SENSOR (DIESEL 2.7V6)	Fig. 03.7	Fig. 03.4
ACTIVE SECURITY SOUNDER	Fig. 12.3	Fig. 03.6
ADAPTIVE DAMPING CONTROL MODULE	Fig. 05.4	Fig. 03.8
.	Fig. 20.2	BRAKE FLUID RESERVOIR	Fig. 05.1
AIR BAG IGNITERS – EXCEPT PASSENGER DUAL	Fig. 17.1	BRAKE ON / OFF SWITCH	Fig. 03.1
AIR BAG IGNITERS – PASSENGER DUAL	Fig. 17.2	Fig. 03.3
AIR CONDITIONING ACTUATORS	Fig. 06.1	Fig. 03.5
AIR CONDITIONING COMPRESSOR CLUTCH	Fig. 03.2	Fig. 03.7
.	Fig. 03.4	Fig. 08.3
.	Fig. 03.6	Fig. 08.4
AIR CONDITIONING COMPRESSOR CLUTCH (DIESEL 2.7V6)	Fig. 03.8	C	
AIR CONDITIONING COMPRESSOR CLUTCH RELAY	Fig. 03.2	CATALYTIC CONVERTER TEMPERATURE SENSORS (DIESEL 2.7V6)	Fig. 03.8
.	Fig. 03.4	CD AUTOCHANGER	Fig. 15.1
.	Fig. 03.6	Fig. 15.2
AIR CONDITIONING COMPRESSOR CLUTCH RELAY (DIESEL 2.7V6)	Fig. 03.8	Fig. 20.3
AIR CONDITIONING CONTROL MODULE – PANEL	Fig. 06.1	Fig. 20.4
.	Fig. 09.2	Fig. 20.5
.	Fig. 10.2	Fig. 20.6
.	Fig. 20.1	CELLULAR PHONE CONTROL MODULE	Fig. 16.1
AIR CONDITIONING CONTROL MODULE – REMOTE	Fig. 06.1	Fig. 16.2
.	Fig. 10.2	Fig. 20.3
.	Fig. 20.1	Fig. 20.4
AIR CONDITIONING PRESSURE SENSOR	Fig. 03.2	Fig. 20.5
.	Fig. 03.4	Fig. 20.6
.	Fig. 03.6	CENTER CONSOLE SWITCH PACK	Fig. 05.1
AIR CONDITIONING PRESSURE SENSOR (DIESEL 2.7V6)	Fig. 03.8	Fig. 08.1
AIR CONDITIONING TEMPERATURE SENSORS	Fig. 06.1	Fig. 08.2
AM / FM ANTENNA AMPLIFIER	Fig. 15.1	Fig. 08.3
.	Fig. 15.2	Fig. 09.2
APP SENSOR	Fig. 03.1	Fig. 11.6
.	Fig. 03.3	Fig. 12.1
.	Fig. 03.5	Fig. 12.2
.	Fig. 03.9	Fig. 14.1
APP SENSOR (DIESEL 2.7V6)	Fig. 03.7	CIGAR LIGHTER	Fig. 09.2
AUDIO UNIT	Fig. 09.2	Fig. 19.1
.	Fig. 12.3	CIGAR LIGHTER / POWER POINT RELAY	Fig. 19.1
.	Fig. 15.1	CKP SENSOR	Fig. 03.1
.	Fig. 15.2	Fig. 03.3
.	Fig. 16.1	Fig. 03.5
.	Fig. 16.2	CKP SENSOR (DIESEL 2.7V6)	Fig. 03.7
.	Fig. 16.3	CLUTCH CANCEL SWITCH	Fig. 03.2
.	Fig. 20.2	Fig. 04.2
.	Fig. 20.3	CLUTCH PEDAL POSITION SENSOR	Fig. 04.2
.	Fig. 20.4	Fig. 05.2
.	Fig. 20.5	CMP SENSOR (DIESEL 2.7V6)	Fig. 03.7
.	Fig. 20.6	CMP SENSORS	Fig. 03.1
AUXILIARY COOLANT PUMP	Fig. 06.1	Fig. 03.3
AUXILIARY COOLANT PUMP RELAY	Fig. 06.1	Fig. 03.5
AUXILIARY LIGHTING SWITCH	Fig. 07.1	COLUMN AND PEDAL ADJUST SWITCH	Fig. 10.1
.	Fig. 08.1	COOLANT CONTROL VALVE	Fig. 06.1
.	Fig. 08.2	COOLING FAN MODULE	Fig. 03.2
.	Fig. 08.3	Fig. 03.4
.	Fig. 08.5	Fig. 03.6
.	Fig. 09.2	COOLING FAN MODULE (DIESEL 2.7V6)	Fig. 03.8
B		COURTESY LAMPS	Fig. 09.1
BATTERY	Fig. 01.1	D	
.	Fig. 02.1	DAMPER SOLENOIDS	Fig. 05.4
.	Fig. 02.2	DATA LINK CONNECTOR	Fig. 20.1
.	Fig. 02.3	Fig. 20.2
.	Fig. 08.4		

DOOR LATCH ASSEMBLY – DRIVER	Fig. 09.1	EMS CONTROL RELAY	Fig. 01.7
.....	Fig. 10.1	Fig. 01.8
.....	Fig. 12.1	ENGINE CONTROL MODULE	Fig. 01.7
.....	Fig. 12.2	Fig. 02.1
.....	Fig. 12.3	Fig. 02.2
.....	Fig. 14.1	Fig. 03.1
DOOR LATCH ASSEMBLY – LH REAR	Fig. 09.1	Fig. 03.2
.....	Fig. 12.1	Fig. 03.3
.....	Fig. 12.2	Fig. 03.4
.....	Fig. 12.3	Fig. 03.5
DOOR LATCH ASSEMBLY – PASSENGER	Fig. 09.1	Fig. 03.6
.....	Fig. 12.1	Fig. 03.9
.....	Fig. 12.2	Fig. 04.2
.....	Fig. 12.3	Fig. 05.3
DOOR LATCH ASSEMBLY – RH REAR	Fig. 09.1	Fig. 20.1
.....	Fig. 12.1	ENGINE COOLANT LEVEL SENSOR	Fig. 07.1
.....	Fig. 12.2	EOT SENSOR	Fig. 03.1
.....	Fig. 12.3	Fig. 03.3
DOOR MIRRORS	Fig. 10.2	Fig. 03.5
.....	Fig. 10.3	EOT SENSOR (DIESEL 2.7V6)	Fig. 03.7
DOOR SWITCH PACK – DRIVER	Fig. 09.2	EVAP CANISTER PURGE VALVE	Fig. 03.1
.....	Fig. 10.1	Fig. 03.3
.....	Fig. 10.2	Fig. 03.5
.....	Fig. 10.3	EXTERNAL TRUNK RELEASE SWITCH	Fig. 12.1
.....	Fig. 11.1	Fig. 12.2
.....	Fig. 14.1		
DOOR SWITCH PACK – LH REAR	Fig. 14.1	F	
DOOR SWITCH PACK – PASSENGER	Fig. 14.1	FASCIA LAMPS	Fig. 09.1
DOOR SWITCH PACK – RH REAR	Fig. 14.1	FPDB MEGAFUSE	Fig. 02.1
DOSING PUMP (DIESEL 2.7V6)	Fig. 03.8	Fig. 02.2
DPF PRESSURE SENSOR (DIESEL 2.7V6)	Fig. 03.7	FPDB MEGAFUSE (DIESEL 2.7V6)	Fig. 02.3
DPF TEMPERATURE SENSOR (DIESEL 2.7V6)	Fig. 03.8	FRONT ELECTRONIC MODULE	Fig. 01.6
DRIVER DOOR MODULE	Fig. 09.1	Fig. 05.2
.....	Fig. 10.1	Fig. 07.1
.....	Fig. 10.2	Fig. 08.1
.....	Fig. 10.3	Fig. 08.2
.....	Fig. 11.1	Fig. 09.1
.....	Fig. 12.1	Fig. 09.2
.....	Fig. 12.2	Fig. 10.1
.....	Fig. 12.3	Fig. 10.2
.....	Fig. 14.1	Fig. 12.1
.....	Fig. 20.2	Fig. 12.2
DRIVER SEAT MODULE	Fig. 11.1	Fig. 12.3
.....	Fig. 11.2	Fig. 13.1
.....	Fig. 20.2	Fig. 19.1
DRIVER SEAT POSITION SWITCH	Fig. 17.1	Fig. 20.2
DSC VACUUM SENSOR	Fig. 05.1	FRONT FOG LAMP RELAY	Fig. 08.1
DYNAMIC STABILITY CONTROL MODULE	Fig. 05.1	Fig. 08.2
.....	Fig. 05.3	FRONT FOG LAMPS	Fig. 08.1
.....	Fig. 05.4	Fig. 08.2
.....	Fig. 20.1	FRONT POWER DISTRIBUTION FUSE BOX	Fig. 01.1
		Fig. 01.2
E		Fig. 01.5
ECT SENSOR	Fig. 03.1	Fig. 01.7
.....	Fig. 03.3	Fig. 01.8
.....	Fig. 03.5	Fig. 02.1
ECT SENSOR (DIESEL 2.7V6)	Fig. 03.7	Fig. 02.2
EFT SENSOR	Fig. 03.1	Fig. 03.2
.....	Fig. 03.3	Fig. 03.4
.....	Fig. 03.5	Fig. 03.6
EFT SENSOR (DIESEL 2.7V6)	Fig. 03.7	Fig. 03.9
EGR THROTTLE BODY (DIESEL 2.7V6)	Fig. 03.7	Fig. 06.1
EGR VALVE	Fig. 03.5	Fig. 08.1
EGR VALVES (DIESEL 2.7V6)	Fig. 03.7	Fig. 08.2
ELECTROCHROMIC REAR VIEW MIRROR		Fig. 12.3
AND COMPASS	Fig. 10.3	Fig. 13.1
ELECTRONIC ROAD PRICING MODULE	Fig. 19.1	Fig. 19.1

FRONT POWER DISTRIBUTION FUSE BOX (DIESEL 2.7V6)	Fig. 02.3	HORNS	Fig. 12.3
.....	Fig. 03.8	Fig. 19.1
FRP SENSOR (DIESEL 2.7V6)	Fig. 03.7	HUMIDITY SENSOR	Fig. 06.1
FUEL FLAP AND TRUNK RELEASE SWITCH PACK	Fig. 05.3	I	
.....	Fig. 09.2	IGNITION CAPACITOR	Fig. 03.2
.....	Fig. 12.1	Fig. 03.4
.....	Fig. 12.2	IGNITION COIL RELAY	Fig. 03.6
FUEL FLAP RELAY	Fig. 12.1	Fig. 01.7
.....	Fig. 12.2	IGNITION MODULES AND COILS	Fig. 03.2
FUEL FLAP RELEASE SOLENOID	Fig. 12.1	Fig. 03.4
.....	Fig. 12.2	Fig. 03.6
FUEL INJECTORS	Fig. 03.2	IGNITION SWITCH	Fig. 01.1
.....	Fig. 03.4	Fig. 01.4
.....	Fig. 03.6	Fig. 01.5
FUEL INJECTORS (DIESEL 2.7V6)	Fig. 03.8	Fig. 02.1
FUEL LEVEL SENSORS	Fig. 07.1	Fig. 02.2
FUEL LIFT PUMP (DIESEL 2.7V6)	Fig. 03.8	Fig. 04.1
FUEL LIFT PUMP RELAY (DIESEL 2.7V6)	Fig. 03.8	Fig. 07.1
FUEL LOW LEVEL SWITCH (DIESEL)	Fig. 07.1	Fig. 12.3
FUEL PUMP	Fig. 03.2	IGNITION SWITCH (DIESEL 2.7V6)	Fig. 02.3
.....	Fig. 03.4	IMPACT SENSORS	Fig. 17.1
.....	Fig. 03.6	IMT SOLENOID VALVES	Fig. 03.1
FUEL PUMP (DIESEL 2.7V6)	Fig. 03.8	INCLINATION SENSOR	Fig. 12.3
FUEL PUMP MODULE	Fig. 03.6	INERTIA SWITCH	Fig. 01.5
FUEL PUMP RELAY	Fig. 03.2	INLET PORT SOLENOID (DIESEL 2.7V6)	Fig. 03.7
.....	Fig. 03.4	INSTRUMENT CLUSTER	Fig. 02.1
.....	Fig. 03.6	Fig. 02.2
FUEL TANK CONNECTOR (DIESEL 2.7V6)	Fig. 03.8	Fig. 05.3
FUEL-FIRED AUXILIARY HEATER MODULE (DIESEL 2.7V6)	Fig. 03.8	Fig. 05.4
.....	Fig. 20.1	Fig. 07.1
		Fig. 08.1
		Fig. 08.2
		Fig. 08.3
		Fig. 09.1
		Fig. 09.2
		Fig. 10.1
		Fig. 10.2
		Fig. 12.3
		Fig. 19.1
		Fig. 20.1
		Fig. 20.2
G		INSTRUMENT CLUSTER (DIESEL 2.7V6)	Fig. 02.3
GENERATOR	Fig. 02.1	INTERCOOLER PUMP	Fig. 03.6
.....	Fig. 02.2	INTERCOOLER PUMP RELAY	Fig. 01.7
GENERATOR (DIESEL 2.7V6)	Fig. 02.3	IP SENSOR	Fig. 03.1
GLOVE BOX LAMP	Fig. 09.1	Fig. 03.3
GLOW PLUG CONTROL MODULE	Fig. 03.8	Fig. 03.5
GLOW PLUG MIDIFUSE	Fig. 02.3	J	
GLOW PLUGS	Fig. 03.8	J-GATE MODULE	Fig. 04.1
		Fig. 09.2
		Fig. 20.1
H		K	
HAND SET RECEIVER	Fig. 16.1	KNOCK SENSORS	Fig. 03.1
.....	Fig. 16.2	Fig. 03.3
HEADLAMP LEVELING ACTUATORS	Fig. 08.5	Fig. 03.5
HEADLAMP LEVELING CONTROL MODULE	Fig. 08.5	KNOCK SENSORS (DIESEL 2.7V6)	Fig. 03.7
.....	Fig. 20.1	L	
.....	Fig. 20.2	LATERAL ACCELEROMETER	Fig. 05.4
HEADLAMP UNITS (HID)	Fig. 08.2	LEAK DETECTION UNIT (NAS ONLY)	Fig. 03.2
.....	Fig. 08.5	Fig. 03.4
HEADLAMP UNITS (NOT HID)	Fig. 08.1	Fig. 03.6
HEATED REAR WINDOW	Fig. 10.2	LH WINDSHIELD HEATER	Fig. 06.1
.....	Fig. 15.1	LH WINDSHIELD HEATER RELAY	Fig. 06.1
.....	Fig. 15.2		
HEATED REAR WINDOW RELAY	Fig. 10.2		
HID RELAYS	Fig. 08.2		
HIGH-MOUNTED STOP LAMP	Fig. 08.3		
.....	Fig. 08.4		
HO2 SENSORS	Fig. 03.1		
.....	Fig. 03.3		
.....	Fig. 03.5		
HO2S RELAY	Fig. 01.7		
HOOD AJAR SWITCH	Fig. 12.3		
HORN RELAY	Fig. 12.3		
.....	Fig. 19.1		

LICENSE PLATE LAMPS	Fig. 08.3	PASSIVE SECURITY SOUNDER	Fig. 12.3
.....	Fig. 08.4	PEDAL ADJUST MOTOR	Fig. 10.1
LUMBAR PUMP – DRIVER	Fig. 11.1	POWER AMPLIFIER	Fig. 15.2
.....	Fig. 11.2	Fig. 20.3
.....	Fig. 11.3	Fig. 20.4
LUMBAR PUMP – PASSENGER	Fig. 11.4	Fig. 20.5
.....	Fig. 11.5	Fig. 20.6
LUMBAR SOLENOIDS – DRIVER	Fig. 11.2	POWER POINT	Fig. 19.1
LUMBAR SOLENOIDS – PASSENGER	Fig. 11.5	POWER WASH PUMP	Fig. 13.1
M		POWER WASH RELAY	Fig. 13.1
MAF SENSOR	Fig. 03.1	POWERTRAIN CONTROL MODULE (DIESEL 2.7V6)	Fig. 01.8
.....	Fig. 03.3	Fig. 02.3
.....	Fig. 03.5	Fig. 03.7
MAF SENSORS (DIESEL 2.7V6)	Fig. 03.7	Fig. 03.8
MAIN LIGHTING SWITCH (COLUMN SWITCHGEAR)	Fig. 08.1	Fig. 04.2
.....	Fig. 08.2	Fig. 20.1
.....	Fig. 08.3	PRIMARY JUNCTION FUSE BOX	Fig. 01.3
.....	Fig. 09.2	Fig. 01.4
MAP LAMPS	Fig. 09.1	Fig. 01.5
MAP SENSOR	Fig. 03.1	Fig. 01.6
.....	Fig. 03.3	Fig. 02.1
MAP SENSOR (DIESEL 2.7V6)	Fig. 03.7	Fig. 02.2
MEGAFUSES	Fig. 01.1	Fig. 09.2
		Fig. 19.1
N		PRIMARY JUNCTION FUSE BOX (DIESEL 2.7V6)	Fig. 02.3
NAVIGATION CONTROL MODULE	Fig. 16.1	R	
.....	Fig. 16.2	RAIN SENSING MODULE	Fig. 13.1
.....	Fig. 16.4	RAIN SENSING UNIT	Fig. 13.1
.....	Fig. 16.5	REAR ELECTRONIC MODULE	Fig. 01.6
.....	Fig. 20.2	Fig. 03.2
.....	Fig. 20.3	Fig. 03.4
.....	Fig. 20.4	Fig. 03.6
.....	Fig. 20.5	Fig. 05.4
.....	Fig. 20.6	Fig. 07.1
NAVIGATION GPS ANTENNA	Fig. 16.4	Fig. 08.3
.....	Fig. 16.5	Fig. 08.4
NAVIGATION SCREEN AND TELEMATICS DISPLAY	Fig. 16.4	Fig. 09.1
.....	Fig. 16.5	Fig. 10.2
NEUTRAL SWITCH	Fig. 04.2	Fig. 10.3
.....	Fig. 05.2	Fig. 12.1
		Fig. 12.2
O		Fig. 12.3
OCCUPANCY SENSING CONTROL MODULE	Fig. 17.2	Fig. 14.1
OIL PRESSURE SWITCH	Fig. 07.1	Fig. 20.2
P		REAR ELECTRONIC MODULE (DIESEL 2.7V6)	Fig. 03.8
PARKING AID MODULE	Fig. 18.1	REAR POWER DISTRIBUTION FUSE BOX	Fig. 01.1
.....	Fig. 20.2	Fig. 01.2
PARKING AID SENSORS	Fig. 18.1	Fig. 01.3
PARKING AID SOUNDERS	Fig. 18.1	Fig. 01.4
PARKING AID SWITCH	Fig. 18.1	Fig. 01.5
PARKING BRAKE MODULE	Fig. 01.5	Fig. 01.6
.....	Fig. 04.2	Fig. 03.2
.....	Fig. 05.2	Fig. 03.4
.....	Fig. 20.1	Fig. 03.6
PARKING BRAKE MOTOR	Fig. 05.2	Fig. 05.2
PARKING BRAKE SWITCH	Fig. 05.2	Fig. 06.1
PASSENGER AIR BAG DEACTIVATED INDICATOR LAMP	Fig. 17.2	Fig. 10.2
PASSENGER SEAT WEIGHT PRESSURE SENSOR	Fig. 17.2	Fig. 12.1
PASSENGER SEAT WEIGHT SENSING CONTROL MODULE	Fig. 17.2	Fig. 12.2
PASSIVE ANTI-THEFT SYSTEM TRANSCEIVER	Fig. 02.1	Fig. 19.1
.....	Fig. 02.2	REAR POWER DISTRIBUTION FUSE BOX (DIESEL 2.7V6)	Fig. 03.8
.....	Fig. 12.3	REMOTE KEYLESS ENTRY MODULE	Fig. 12.1
PASSIVE ANTI-THEFT SYSTEM TRANSCEIVER (DIESEL 2.7V6)	Fig. 02.3	Fig. 12.3
		RESTRAINTS CONTROL MODULE	Fig. 17.1
		Fig. 17.2
		Fig. 20.2

REVERSE SWITCH	Fig. 04.2	STEERING WHEEL AUDIO SWITCHES	Fig. 15.1
.....	Fig. 08.3	Fig. 15.2
RIDE HEIGHT SENSORS	Fig. 08.5	Fig. 16.2
ROOF CONSOLE	Fig. 09.1	Fig. 16.3
.....	Fig. 09.2	STEERING WHEEL HORN SWITCH	Fig. 19.1
.....	Fig. 12.3	STEERING WHEEL LIGHTING	Fig. 09.2
.....	Fig. 14.1	STEERING WHEEL SPEED CONTROL SWITCHES	Fig. 03.2
.....	Fig. 16.1	Fig. 03.4
.....	Fig. 16.2	Fig. 03.6
.....	Fig. 16.3	Fig. 03.8
.....	Fig. 16.5	Fig. 05.3
.....	Fig. 19.1	SUBWOOFERS	Fig. 15.2
.....	Fig. 20.2	SUN SHADE MOTOR	Fig. 19.1
ROTARY ELECTRONIC ACTUATORS (DIESEL 2.7V6)	Fig. 03.7	SUN VISOR LAMPS	Fig. 09.1
S		SWITCHED SYSTEM POWER RELAYS	Fig. 01.6
SAFETY BELT PRETENSIONER IGNITERS	Fig. 17.1	T	
SAFETY BELT SWITCHES	Fig. 17.1	TAIL LAMP UNITS	Fig. 08.3
SAFETY BELT TENSION SENSOR	Fig. 17.2	Fig. 08.4
SAI MAP SENSOR (NAS ONLY)	Fig. 03.9	TELEMATICS DISPLAY	Fig. 09.2
SAI PUMP (NAS ONLY)	Fig. 03.9	Fig. 16.1
SAI RELAY (NAS ONLY)	Fig. 03.9	Fig. 16.2
SEAT BACK HEATERS	Fig. 11.6	TELEPHONE ANTENNA	Fig. 16.2
SEAT CUSHION HEATERS	Fig. 11.6	THR SENSOR	Fig. 03.5
SEAT HEATER MODULES	Fig. 11.6	THROTTLE BODY	Fig. 03.1
SEAT MOTORS AND POSITION SENSORS – DRIVER	Fig. 11.1	Fig. 03.3
.....	Fig. 11.2	THROTTLE MOTOR	Fig. 03.1
.....	Fig. 11.3	Fig. 03.3
SEAT MOTORS AND POSITION SENSORS –		Fig. 03.5
PASSENGER	Fig. 11.5	TMAP SENSOR	Fig. 03.5
SEAT MOTORS – PASSENGER	Fig. 11.4	TP SENSOR	Fig. 03.1
SEAT SWITCH PACK – DRIVER	Fig. 11.1	Fig. 03.3
.....	Fig. 11.2	Fig. 03.5
.....	Fig. 11.3	TRAILER TOWING CONNECTORS	Fig. 08.4
SEAT SWITCH PACK – PASSENGER	Fig. 11.4	TRAILER TOWING CONTROL MODULE	Fig. 08.4
.....	Fig. 11.5	TRAILER TOWING JUNCTION BOX	Fig. 08.4
SECURITY INDICATOR	Fig. 12.3	TRAILER TOWING RELAY	Fig. 08.4
SIDE MARKER LAMPS	Fig. 08.3	TRANSIT ISOLATION RELAY	Fig. 01.1
.....	Fig. 08.4	TRANSMISSION CAPACITORS	Fig. 04.1
SIDE MARKERS	Fig. 08.1	TRANSMISSION CONTROL MODULE	Fig. 02.1
.....	Fig. 08.2	Fig. 02.2
SLIDING ROOF CONTROL MODULE	Fig. 14.1	Fig. 04.1
SOLAR SENSOR	Fig. 06.1	Fig. 05.3
.....	Fig. 08.1	Fig. 20.1
.....	Fig. 08.2	TRANSMISSION CONTROL MODULE (DIESEL 2.7V6)	Fig. 02.3
SPATIAL SENSORS	Fig. 17.2	TRIP CYCLE SWITCH (COLUMN SWITCHGEAR)	Fig. 07.1
SPEAKERS	Fig. 15.1	TRUNK AJAR SWITCH	Fig. 09.1
.....	Fig. 15.2	Fig. 12.1
SPEED CONTROL MODULE	Fig. 05.3	TRUNK LAMP – LH	Fig. 09.1
.....	Fig. 20.1	TRUNK LID LAMP	Fig. 09.1
SPEED CONTROL SENSOR	Fig. 05.3	TRUNK LID LATCH ASSEMBLY	Fig. 12.2
STARTER MEGAFUSE	Fig. 02.1	Fig. 12.3
.....	Fig. 02.2	TRUNK RELEASE SOLENOID	Fig. 12.1
STARTER MEGAFUSE (DIESEL 2.7V6)	Fig. 02.3	TURN REPEATERS	Fig. 08.1
STARTER MOTOR	Fig. 02.1	Fig. 08.2
.....	Fig. 02.2	TV ANTENNAS AND AMPLIFIERS	Fig. 16.5
STARTER MOTOR (DIESEL 2.7V6)	Fig. 02.3	V	
STARTER RELAY	Fig. 02.1	VACUUM SOLENOID	Fig. 03.9
.....	Fig. 02.2	VALET SWITCH	Fig. 12.1
STARTER RELAY (DIESEL 2.7V6)	Fig. 02.3	Fig. 12.2
STEERING ANGLE SENSOR	Fig. 05.1	VARIABLE ASSIST STEERING ACTUATOR	Fig. 05.2
STEERING COLUMN LOCK MODULE	Fig. 12.3	VEHICLE INFORMATION ANTENNA	Fig. 16.5
.....	Fig. 20.2	VEHICLE INFORMATION CONTROL MODULE	Fig. 16.5
STEERING COLUMN MOTOR, SOLENOIDS		VEHICLE INFORMATION SENSOR	Fig. 16.5
AND POSITION SENSORS	Fig. 10.1	VERTICAL ACCELEROMETERS	Fig. 05.4

VOICE ACTIVATION MODULE	Fig. 16.3
.....	Fig. 20.3
.....	Fig. 20.4
.....	Fig. 20.5
.....	Fig. 20.6
VVT SOLENOID VALVES.....	Fig. 03.1
.....	Fig. 03.3
.....	Fig. 03.5

W

WASHER FLUID LEVEL SWITCH	Fig. 07.1
.....	Fig. 13.1
WHEEL SPEED SENSORS	Fig. 05.1
WINDOW MOTOR ASSEMBLIES	Fig. 14.1
WINDOW SWITCHES.....	Fig. 09.2
WINDSHIELD WASHER PUMP	Fig. 13.1
WIPE / WASH SWITCH	Fig. 13.1
WIPER HIGH / LOW RELAY.....	Fig. 13.1
WIPER MOTOR ASSEMBLY	Fig. 13.1
WIPER PARK HEATER OR RH WINDSHIELD HEATER ..	Fig. 06.1
WIPER PARK HEATER / RH WINDSHIELD HEATER RELAY.....	Fig. 06.1
WIPER PARK RELAY.....	Fig. 13.1

Y

YAW RATE AND LATERAL ACCELERATION SENSORS CLUSTER.....	Fig. 05.1
---	-----------

