



BY APPOINTMENT TO
HER MAJESTY QUEEN ELIZABETH II
MANUFACTURERS OF DAIMLER AND JAGUAR CARS
JAGUAR CARS LIMITED COVENTRY



BY APPOINTMENT TO
HER MAJESTY QUEEN ELIZABETH
THE QUEEN MOTHER
MANUFACTURERS OF DAIMLER AND JAGUAR CARS
JAGUAR CARS LIMITED COVENTRY



BY APPOINTMENT TO
HIS ROYAL HIGHNESS THE PRINCE OF WALES
MANUFACTURERS OF DAIMLER AND JAGUAR CARS
JAGUAR CARS LIMITED COVENTRY

X-TYPE

Sedan and Sports Brake Electrical Guide

2.0 L, 2.5 L and 3.0 L Gasoline; 2.0 L Diesel
Model Years: Sedan 2004.25, Sports Brake 2004.5

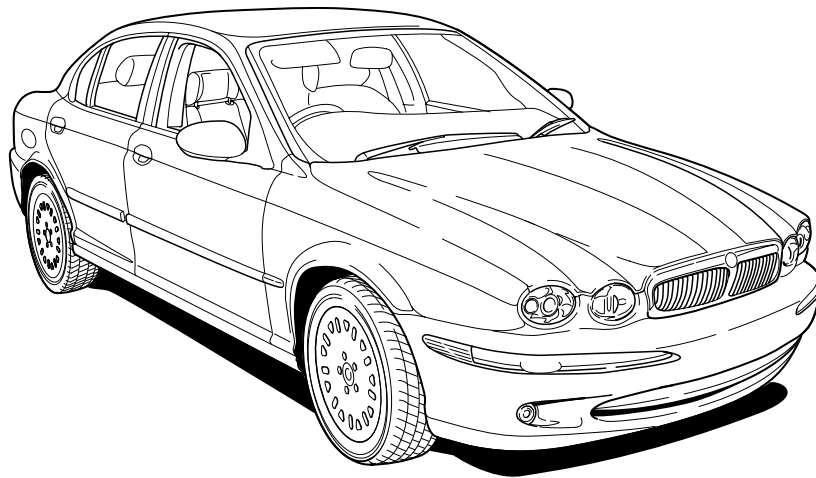

PROVISIONAL

Published by Parts and Service Communications
Jaguar Cars Limited

Publication Part Number – JTP 977





Table of Contents 1

Table of Contents: Figures 2 – 3

Abbreviations and Acronyms 4

Introduction 5

Symbols and Codes 6 – 9

Network Configuration 10

Relay and Fuse Location 11 – 12

Fuse Box Connectors 13

Major Harnesses and Fuse Box Location 14 – 15

Harness In-Line Connector Location 16 – 18

Ground Point Location 19

Control Module Location 20 – 21

Electrical Guide Figures follows after page 21
(pages are numbered by Figure number)



FIGURES

Fig.	Description	Variant
01	Power Distribution	
01.1	Main Power Distribution	All Vehicles
01.2	Battery Power Distribution: Part 1	All Vehicles
01.3	Battery Power Distribution: Part 2	All Vehicles
01.4	Ignition Switched Power Distribution: I (Accessory)	All Vehicles
01.5	Ignition Switched Power Distribution: II (Run) – Part 1	All Vehicles
01.6	Ignition Switched Power Distribution: II (Run) – Part 2	All Vehicles
01.7	Ignition Switched Power Distribution: Battery Saver	All Vehicles
01.8	EMS Switched Power Distribution: Gasoline Engines	Gasoline Engine Vehicles
01.9	EMS Switched Power Distribution: Diesel Engine	Diesel Engine Vehicles
02	Battery; Starter; Generator	
02.1	Battery; Starter; Generator: 2.5 L & 3.0 L	2.5 L & 3.0 L Vehicles
02.2	Battery; Starter; Generator: 2.0 L	2.0 L Gasoline Engine Vehicles
02.3	Battery; Starter; Generator: 2.0 L D	2.0 L Diesel Engine Vehicles
03	Engine Management	
03.1	Engine Management: 2.5 L & 3.0 L – Part 1	2.5 L & 3.0 L Vehicles
03.2	Engine Management: 2.5 L & 3.0 L – Part 2	2.5 L & 3.0 L Vehicles
03.3	Engine Management: 2.0 L – Part 1	2.0 L Gasoline Engine Vehicles
03.4	Engine Management: 2.0 L – Part 2	2.0 L Gasoline Engine Vehicles
03.5	Engine Management: 2.0 L D – Part 1	2.0 L Diesel Engine Vehicles
03.6	Engine Management: 2.0 L D – Part 2	2.0 L Diesel Engine Vehicles
04	Transmission	
04.1	Automatic Transmission: 16-Bit TCM	16-Bit TCM Vehicles
04.2	Automatic Transmission: 32-Bit TCM	32-Bit TCM Vehicles
05	Braking	
05.1	Anti-Lock Braking	ABS Vehicles
05.2	Traction Control	ABS / TC Vehicles
05.3	Dynamic Stability Control	DSC Vehicles
06	Climate Control	
06.1	Manual Climate Control	Manual Climate Control Vehicles
06.2	Automatic Climate Control	Automatic Climate Control Vehicles
06.3	Glass Heaters	All Vehicles
07	Instrumentation	
07.1	Instrument Cluster	All Vehicles
07.2	Audible Warnings	All Vehicles
08	Exterior Lighting	
08.1	Exterior Lighting: Front – Auto Headlamps	Auto Headlamp Vehicles
08.2	Exterior Lighting: Front – Non Autolamps	Non Autolamp Vehicles;
	Exterior Lighting: Front – Daytime Running Lamps	Daytime Running Lamp Vehicles
08.3	Exterior Lighting: Rear – Sedan	Sedan Vehicles
08.4	Exterior Lighting: Rear – Sports Brake (SB)	SB Vehicles
08.5	Exterior Lighting: Rear – Sedan European Trailer Towing	Euro. Sedan Trailer Towing Vehicles
08.6	Exterior Lighting: Rear – Sedan U.K. Trailer Towing	U.K. Sedan Trailer Towing Vehicles
08.7	Exterior Lighting: Rear – Sedan NAS Trailer Towing	NAS Sedan Trailer Towing Vehicles
08.8	Exterior Lighting: Rear – SB European Trailer Towing	Euro. SB Trailer Towing Vehicles
08.9	Exterior Lighting: Rear – SB U.K. Trailer Towing	U.K. SB Trailer Towing Vehicles
08.10	Exterior Lighting: Rear – SB NAS Trailer Towing	NAS SB Trailer Towing Vehicles
08.11	Headlamp Leveling (H/L)	H/L & HID Headlamp Vehicles
09	Interior Lighting	
09.1	Interior Lighting	All Vehicles
09.2	Dimmer-Controlled Lighting	All Vehicles

**FIGURES**

Fig.	Description	Variant
10	Steering; Mirrors; Heaters	
10.1	Variable Assist Steering; Electrochromic Rear View Mirror	All Vehicles
10.2	Door Mirrors: Movement; Fold-Back – Non Memory	Non Memory Vehicles
10.3	Door Mirrors: Movement; Fold-Back – Memory	Memory Vehicles
11	Seat Systems	
11.1	Powered Seat: Driver – Memory	Memory Vehicles
11.2	Powered Seat: Passenger – Memory	Memory Vehicles
11.3	Powered Seats: 8-Way Movement	8-Way Powered Seat Vehicles
11.4	Powered Seats: 2-Way Movement	2-Way Powered Seat Vehicles
11.5	Seat Heaters: Memory	Memory Vehicles
11.6	Seat Heaters: Non Memory	Heated Seat Vehicles
12	Door Locking; Security	
12.1	Central Door Locking: Sedan – Double Locking	Double Locking Sedan Vehicles
12.2	Central Door Locking: Sedan – Non Double Locking	Non Double Locking Sedan Vehicles
12.3	Central Door Locking: Sports Brake	Sports Brake Vehicles
12.4	Security: Sedan	Sedan Vehicles
12.5	Security: Sports Brake	Sports Brake Vehicles
13	Wash / Wipe	
13.1	Wash / Wipe: Front	Non Rain Sensing Vehicles
13.2	Wash / Wipe: Front with Rain Sensing	Rain Sensing Vehicles
13.3	Wash / Wipe: Rear	Sports Brake Vehicles
14	Powered Windows; Sliding Roof	
14.1	Powered Windows	All Vehicles
14.2	Sliding Roof	Sliding Roof Vehicles
15	In-Car Entertainment	
15.1	In-Car Entertainment – Standard	Standard ICE Vehicles
15.2	In-Car Entertainment – Premium	Premium ICE Vehicles
16	Telematics	
16.1	Telephone: ROW	ROW Vehicles
16.2	Telephone: NAS	NAS Vehicles
16.3	Telephone with Voice Control: ROW	ROW Voice Vehicles
16.4	Telephone with Voice Control: NAS	NAS Voice Vehicles
16.5	Navigation System	NAV Vehicles (except Japan)
16.6	Navigation System: Japan	Japan Vehicles
17	Occupant Protection	
17.1	Advanced Restraint System: Sedan	Sedan Vehicles
17.2	Advanced Restraint System: Sports Brake	Sports Brake Vehicles
18	Driver Assist	
18.1	Parking Aid	Parking Aid Vehicles
19	Ancillaries	
19.1	Ancillaries: Horn; Cigar Lighter; Accessory Connectors;	All Vehicles
	Garage Door Opener	
20	Vehicle Multiplex Systems	
20.1	Controller Area Network: LHD	LHD Vehicles
20.2	Controller Area Network: RHD	RHD Vehicles
20.3	Standard Corporate Protocol Network; Serial Data Link	All Vehicles
20.4	D2B Network	All Vehicles



The following abbreviations and acronyms are used throughout this Electrical Guide:

A/C	Air Conditioning
APP SENSOR	Accelerator Pedal Position Sensor
APP1	Accelerator Pedal Position Sensor Element 1
APP2	Accelerator Pedal Position Sensor Element 2
B+	Battery Voltage
BANK 1	RH Cylinder Bank (Cylinders 1, 3, 5, 7)
BANK 2	LH Cylinder Bank (Cylinders 2, 4, 6, 8)
CAN	Controller Area Network
CHT SENSOR	Cylinder Head Temperature Sensor
CKP SENSOR	Crankshaft Position Sensor
CMP SENSOR / 1	Camshaft Position Sensor / RH Bank
CMP SENSOR / 2	Camshaft Position Sensor / LH Bank
D2B	D2B Network
DSC	Dynamic Stability Control
ECT SENSOR	Engine Coolant Temperature Sensor
EFT SENSOR	Engine Fuel Temperature Sensor
EGR VALVE	Exhaust Gas Recirculation Valve
EGT SENSOR	Exhaust Gas Temperature Sensor
EMS	Engine Management System
EOT SENSOR	Engine Oil Temperature Sensor
EVAP CANISTER CLOSE VALVE	Evaporative Emission Canister Close Valve
EVAP CANISTER PURGE VALVE	Evaporative Emission Canister Purge Valve
FTP SENSOR	Fuel Tank Pressure Sensor
GPS	Global Positioning System
HID	High Intensity Discharge
HO2 SENSOR 1 / 1	Heated Oxygen Sensor – RH Bank / Upstream
HO2 SENSOR 1 / 2	Heated Oxygen Sensor – RH Bank / Downstream
HO2 SENSOR 2 / 1	Heated Oxygen Sensor – LH Bank / Upstream
HO2 SENSOR 2 / 2	Heated Oxygen Sensor – LH Bank / Downstream
IAT SENSOR	Intake Air Temperature Sensor
ICE	In-Car Entertainment System
IMT VALVE / 1	Intake Manifold Tuning Valve / Bottom
IMT VALVE / 2	Intake Manifold Tuning Valve / Top
IP SENSOR	Injection Pressure Sensor
KS / 1	Knock Sensor / RH Bank
KS / 2	Knock Sensor / LH Bank
LH	Left Hand
LHD	Left Hand Drive
MAF SENSOR	Mass Air Flow Sensor
MAP SENSOR	Manifold Absolute Pressure Sensor
N/A	Normally Aspirated
NAS	North American Specification
PATS	Passive Anti-Theft System
PWM	Pulse Width Modulated
RH	Right Hand
RHD	Right Hand Drive
ROW	Rest of World
SB	Sports Brake
SCP	Standard Corporate Protocol Network
T-MAP SENSOR	Temperature Manifold Absolute Pressure Sensor
TP SENSOR	Throttle Position Sensor
TP1	Throttle Position Sensor Element 1
TP2	Throttle Position Sensor Element 2
TURN	Turn Signal
TV	Television
V6	V6 Engine
V8	V8 Engine
VVT VALVE / 1	Variable Valve Timing Valve / Bank 1
VVT VALVE / 2	Variable Valve Timing Valve / Bank 2
+ve	Positive
-ve	Negative



Provisional Electrical Guide Format

This Provisional Electrical Guide is an abridged version made up of two sections. The first section provides general information for and about the use of the book, and information and illustrations to aid in the location and identification of components.

The Figure section illustrates detailed electrical circuit information for each system on the vehicle. Each Figure is identified by a Figure Number (i.e. Fig. 01.1) and Title. The data that would normally accompany each Figure is not included in this provisional version.

It is recommended that the user read through the front section of the book to develop a familiarity with the layout of the book and with the system of symbols and abbreviations used. The Table of Contents should help to guide the user.

Vehicle Identification Numbers (VIN)

VIN ranges are presented throughout the book in the following manner:

→ VIN 123456 indicates “up to VIN 123456”; VIN 123456 → indicates “from VIN 123456 on”.

Jaguar 2004 Model Year X-TYPE Electrical System Architecture

Power Supplies

The Jaguar 2004 Model year X-TYPE electrical system is a supply-side switched system. The ignition switch directly carries much of the ignition switched power supply load. Power supply is provided via three methods: direct battery power supply, ignition switched power supply, and “Battery Saver Power Supply”. The “Battery Saver Power Supply” circuit is controlled via the GEM (General Electronic Module). Refer to Figure 01.7 for circuit activation details.

Fuse Boxes

The electrical harness incorporates two serviceable power distribution fuse boxes: the Power Distribution Fuse Box located in the engine compartment and the Passenger Junction Fuse Box located in the left-hand ‘A’ Post. All fuses and relays (except the trailer towing accessory kit and two Diesel vehicle relays) are located in the two fuse boxes.

Vehicle Networks

The X-TYPE employs three different networks: a CAN (Controller Area Network) for high-speed power train communications, an SCP (Standard Corporate Protocol) network for slower speed body systems communications, and a D2B (Optical) Network for very high-speed “real-time” audio data transfer. The D2B Network is a fiber optic network with a gateway to the remaining vehicle networks via the Audio Unit. Technician access to the three networks and the Serial Data Link is via the Data Link Connector.

Ground Studs

Circuit ground connections are made at body studs located throughout the vehicle. There are no separate power and logic grounding systems; however, there are a certain number of components that use unique ground points.



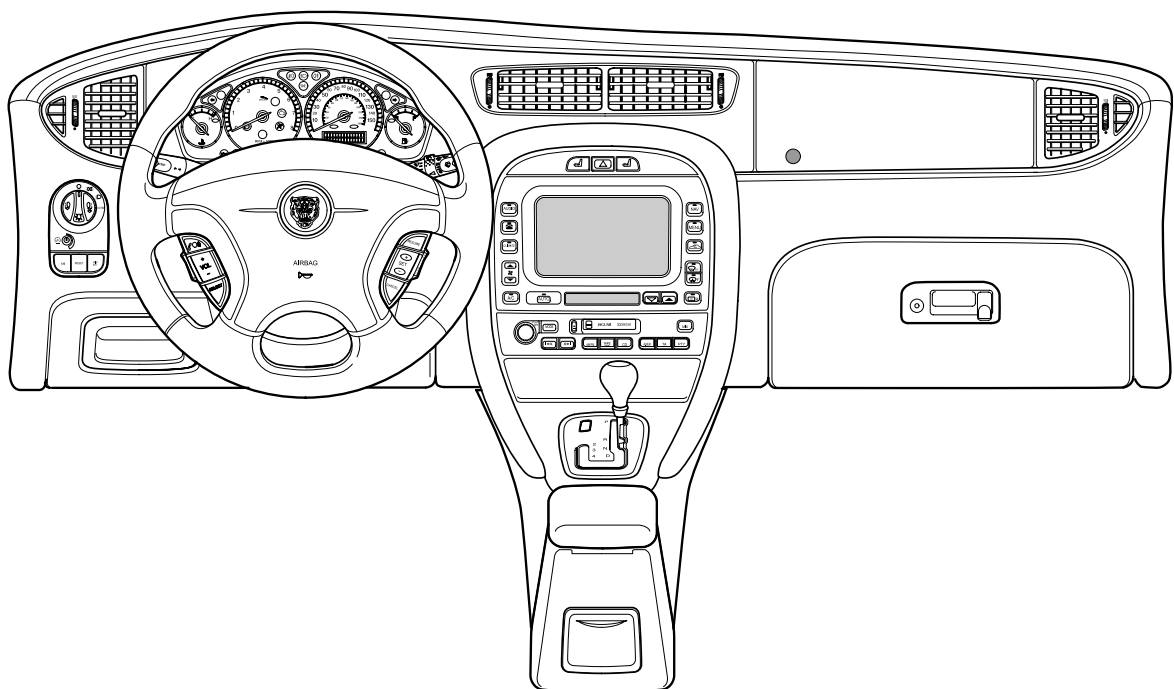





X-TYPE INSTRUMENT PANEL















NOTE: In the examples on this page, an 'X' is used where a number would appear on an actual Figure.

Reference Symbols

-  Battery power supply
-  Ignition switched auxiliary power supply (key I)
-  Ignition switched power supply (key II, III)
-  Ignition switched Battery Saver power supply
-  Engine Management System power supply
-  Figure number reference
-  Controller Area Network
-  Standard Corporate Protocol network
-  D2B network













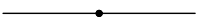
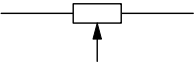
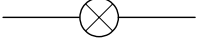
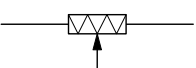
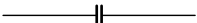

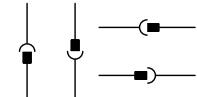

Control Module Pin Symbols

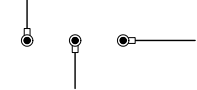
-  Input
-  Output
-  Battery voltage
-  Power ground
-  Sensor/signal supply V *
-  Sensor/signal ground **
-  CAN network
-  SCP network
-  D2B network
-  Serial and encoded data

* May also indicate Reference Voltage.

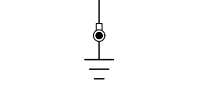
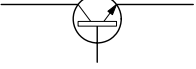
** May also indicate Reference Ground or Logic Ground.
Refer to Control Module Pin-Out Information.

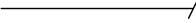
Wiring Symbols

- | | | | |
|----------------------------|---|--|----------------------|
| Splice |  |  | Motor |
| Simplified splice |  |  | Potentiometer |
| Bulb |  |  | Pressure transducer |
| Capacitor |  |  | Resistor |
| Connector |  |  | Solenoid |
| Diode |  |  | Suppression diode |
| Eyelet and stud |  |  | Suppression resistor |
| Fuse |  |  | Thermistor |
| Ground |  |  | Transistor |
| Hall effect sensor |  |  | Wire continued |
| Light emitting diode (LED) |  |  | Zener diode |



Harness Codes

AC	Climate Control
AS	Side Airbag
BH	Engine Block Heaters
BL	LH Rear Door
BR	RH Rear Door
CA	Cabin
DE	Diesel Engine
DL	Diesel Engine Link
EN	Engine
FB	Front Bumper
FL	LH Front Door
FR	RH Front Door
FT	Fuel Tank
GC	Cooling Pack
IJ	Injector Rail
IP	Instrument Panel
JB	Junction Box
LF	LH Front Wheel Speed Sensor
LR	LH Rear Wheel Speed Sensor
LS	LH Front Seat
NA	Navigation System
PA	Pedal Assembly
PH	Telephone
RB	Rear Bumper
RC	Roof Console
RF	RH Front Wheel Speed Sensor
RR	RH Rear Wheel Speed Sensor
RS	RH Front Seat
SL	Security Sounder Link
TL	Trunk Lid
TT	Trailer Towing
TV	Television
WG	Tailgate Glass (Sports Brake only)
WL	Tailgate Link (Sports Brake only)
WS	Weight Sensor
WT	Tailgate (Sports Brake only)

Wiring Color Codes

N	Brown	O	Orange
B	Black	S	Slate
W	White	L	Light
K	Pink	U	Blue
G	Green	P	Purple
R	Red	BRD	Braid
Y	Yellow	BOF	Fiber optic (D2B Network)

Code Numbering

When numbering connectors, grounds and splices, Jaguar Engineering uses a three-position format: AC001, AC002, etc. Because space is limited in this Electrical Guide the codes have, in most cases, been shortened. Thus AC001-001 becomes AC1-1, AC002-001 becomes AC2-1, etc.



Grounds

There may be up to three eyelets on one ground stud. A, B and C are used to indicate the position of the eyelet on the stud: A – first (bottom), B – second (middle), C – third (top). Two eyelet variations are used: a single eyelet and an eyelet pair. The single eyelet has a single ‘leg’, which is identified by an S; the eyelet pair has two ‘legs’, identified as L (left) or R (right).

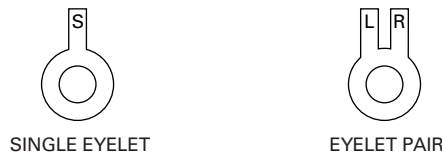

EXAMPLE:



On figures where LHD and RHD circuits are combined and the ground designation differs from LHD to RHD, the RHD ground is shown in parentheses. If the ground designation is the same for LHD and RHD, only one ground designation is used.

EXAMPLE:



Relays

Serviceable Relays

Serviceable relays are located in both fuse boxes. They do not have a separate relay connector (base). All relays use the ISO pin numbering system – 1, 2, 3, 4, 5. Each relay is identified by an “R” number unique only to the fuse box in which it is located.

EXAMPLE:

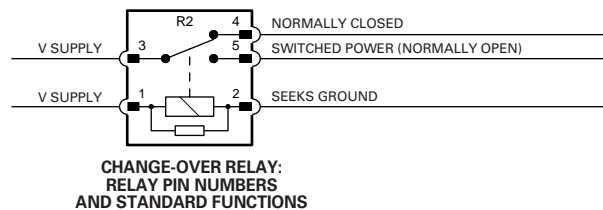

Non-Serviceable Relays

Non-serviceable relays are located in both fuse boxes. They are a component part of the fuse box printed circuit board (PCB) and are arranged in singles or pairs. The relays use the ISO pin numbering system – 1, 2, 3, 4, 5 (single relay or top pair relay) and 6, 7, 8, 9, 10 (bottom pair relay). Each relay is identified by an “R” number unique only to the fuse box in which it is located. Pair relays are normally depicted separately.

EXAMPLE:

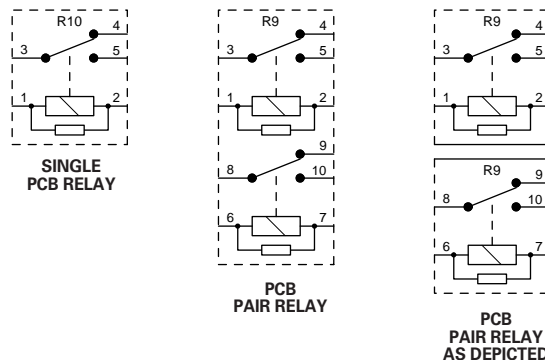

NOTE: Diesel vehicles have one serviceable relay located on the Junction Box harness and one serviceable relay attached to the Power Distribution Fuse Box.



Fuses

All fuses are located in the fuse boxes. Each fuse is identified by an "F" number unique only to the fuse box in which it is located.

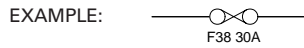

Networks

In most instances, networks are shown as a broken grey line to indicate that there is network communication between the depicted control modules. Refer to Figures 20.1, 20.2, 20.3 and 20.4 for circuit details.

EXAMPLE:

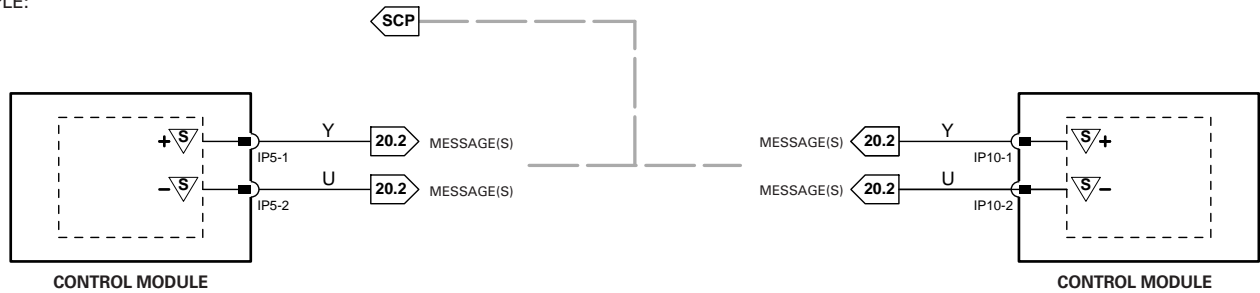

Component Depictions

EXAMPLE:

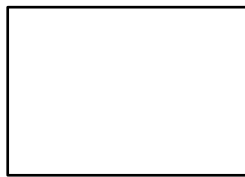

COMPLETE COMPONENTS AND CONTROL MODULES



INCOMPLETE COMPONENTS (EXCEPT CONTROL MODULES)



ASSEMBLIES AND POWER DISTRIBUTION FUSE BOXES

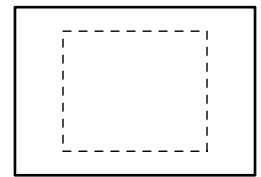

COMPONENTS WITH INTERNAL ELECTRONIC CIRCUIT

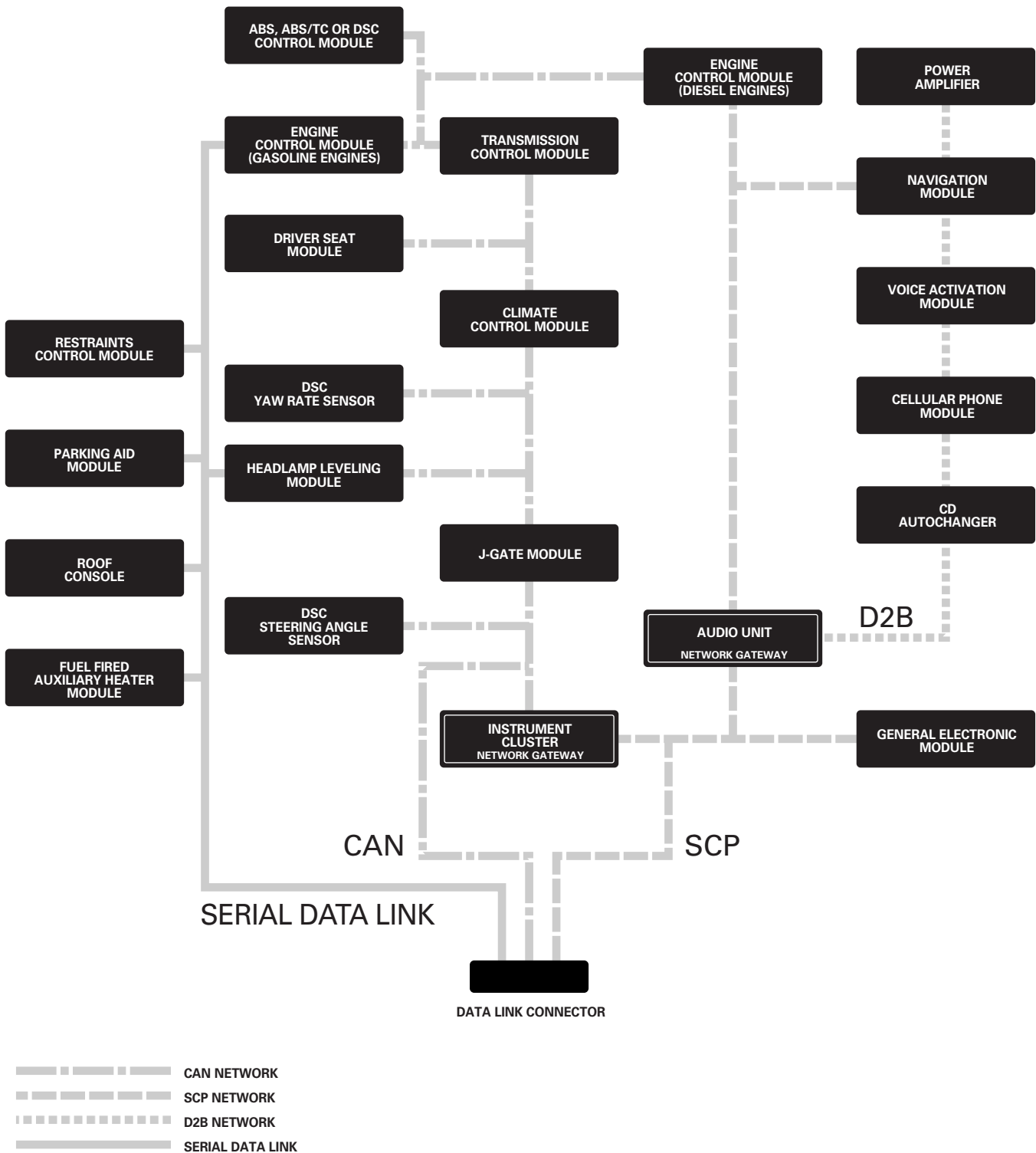

NOTE: TYPICAL NETWORK CONFIGURATION.
REFER TO FIGURES 20.1, 20.2, 20.3 AND 20.4 FOR CIRCUIT DETAILS.



POWER DISTRIBUTION FUSE BOX (TOP): GASOLINE ENGINE VEHICLES

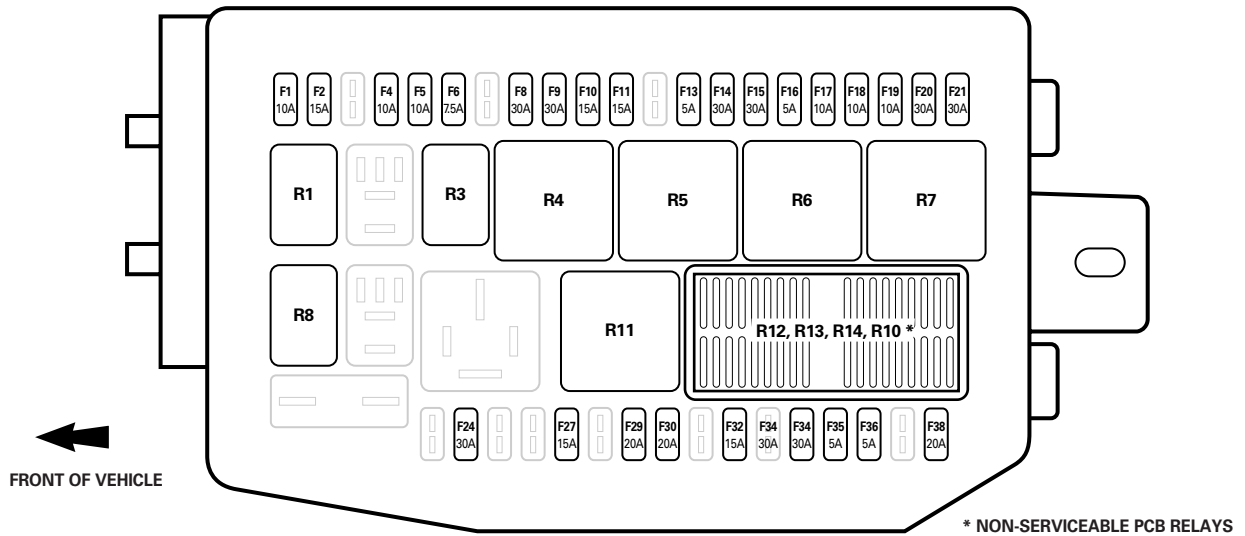

- | | |
|---|--------------------------|
| R1 MAIN BEAM / FRONT FOG RELAY | R9 NOT USED |
| R2 NOT USED | R10 NOT USED |
| R3 A/C COMPRESSOR CLUTCH RELAY | R11 DIP BEAM RELAY |
| R4 WINDSHIELD WIPER MOTOR RELAY | R12 STARTER RELAY |
| R5 POWER DISTRIBUTION FUSE BOX IGNITION RELAY | R13 SLAVE IGNITION RELAY |
| R6 WINDSHIELD HEATER RELAY | R14 NOT USED |
| R7 EMS CONTROL RELAY | R15 HORN RELAY |
| R8 POWERWASH PUMP RELAY | |

POWER DISTRIBUTION FUSE BOX (TOP): DIESEL ENGINE VEHICLES

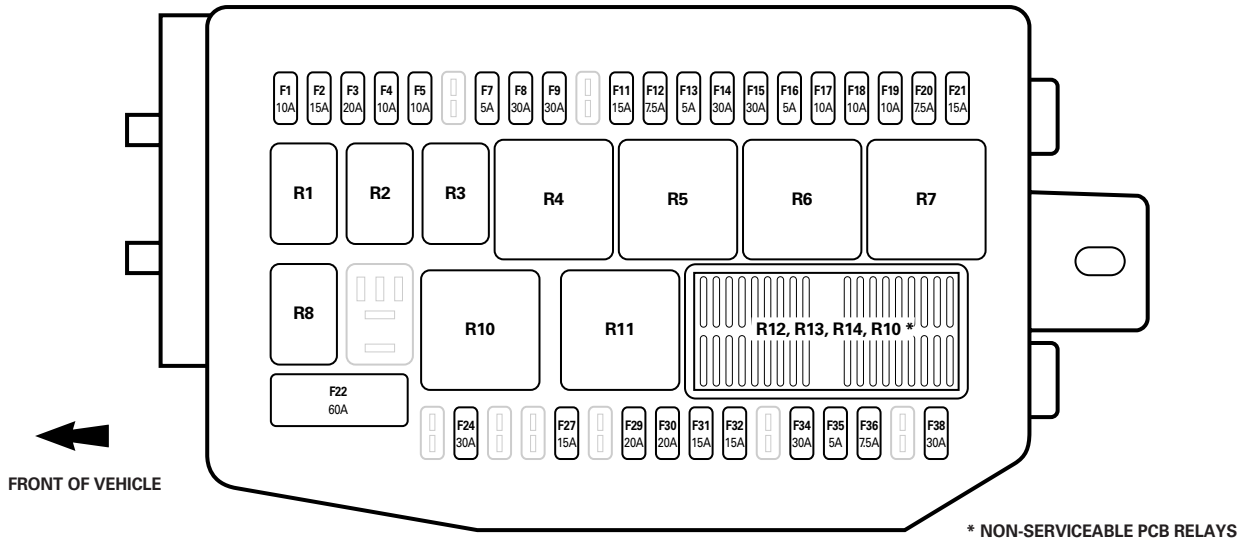

- | | |
|---|------------------------------|
| R1 MAIN BEAM / FRONT FOG RELAY | R9 NOT USED |
| R2 HORN RELAY | R10 GLOW PLUG RELAY |
| R3 A/C COMPRESSOR CLUTCH RELAY | R11 DIP BEAM RELAY |
| R4 WINDSHIELD WIPER MOTOR RELAY | R12 STARTER RELAY |
| R5 POWER DISTRIBUTION FUSE BOX IGNITION RELAY | R13 SLAVE IGNITION RELAY |
| R6 WINDSHIELD HEATER RELAY | R14 NOT USED |
| R7 EMS CONTROL RELAY | R15 AUXILIARY HEATER RELAY 1 |
| R8 POWERWASH PUMP RELAY | |



POWER DISTRIBUTION FUSE BOX (BOTTOM)

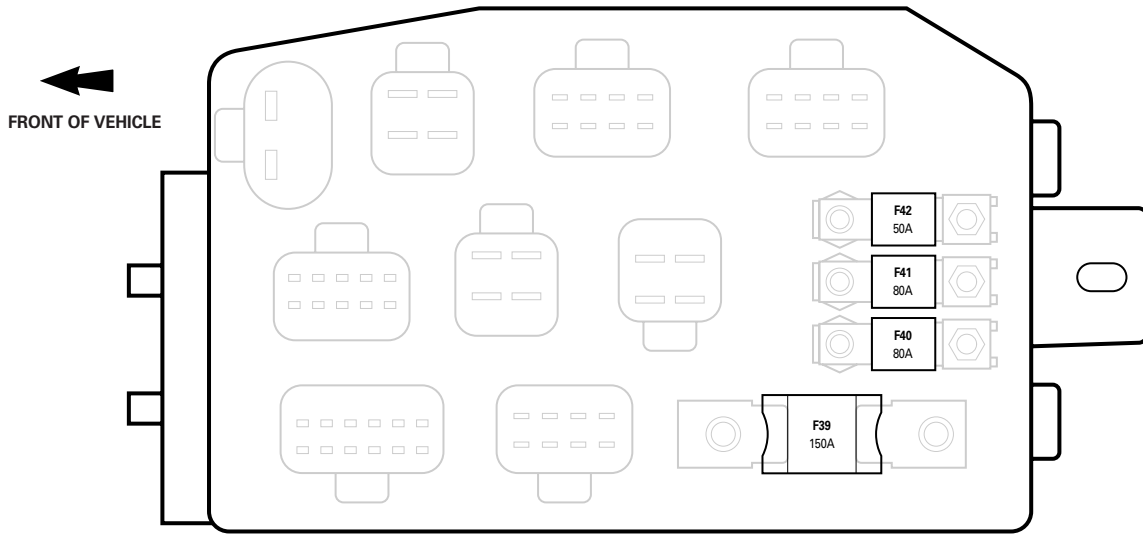

PASSENGER JUNCTION FUSE BOX (FRONT)

PASSENGER JUNCTION FUSE BOX (BACK)

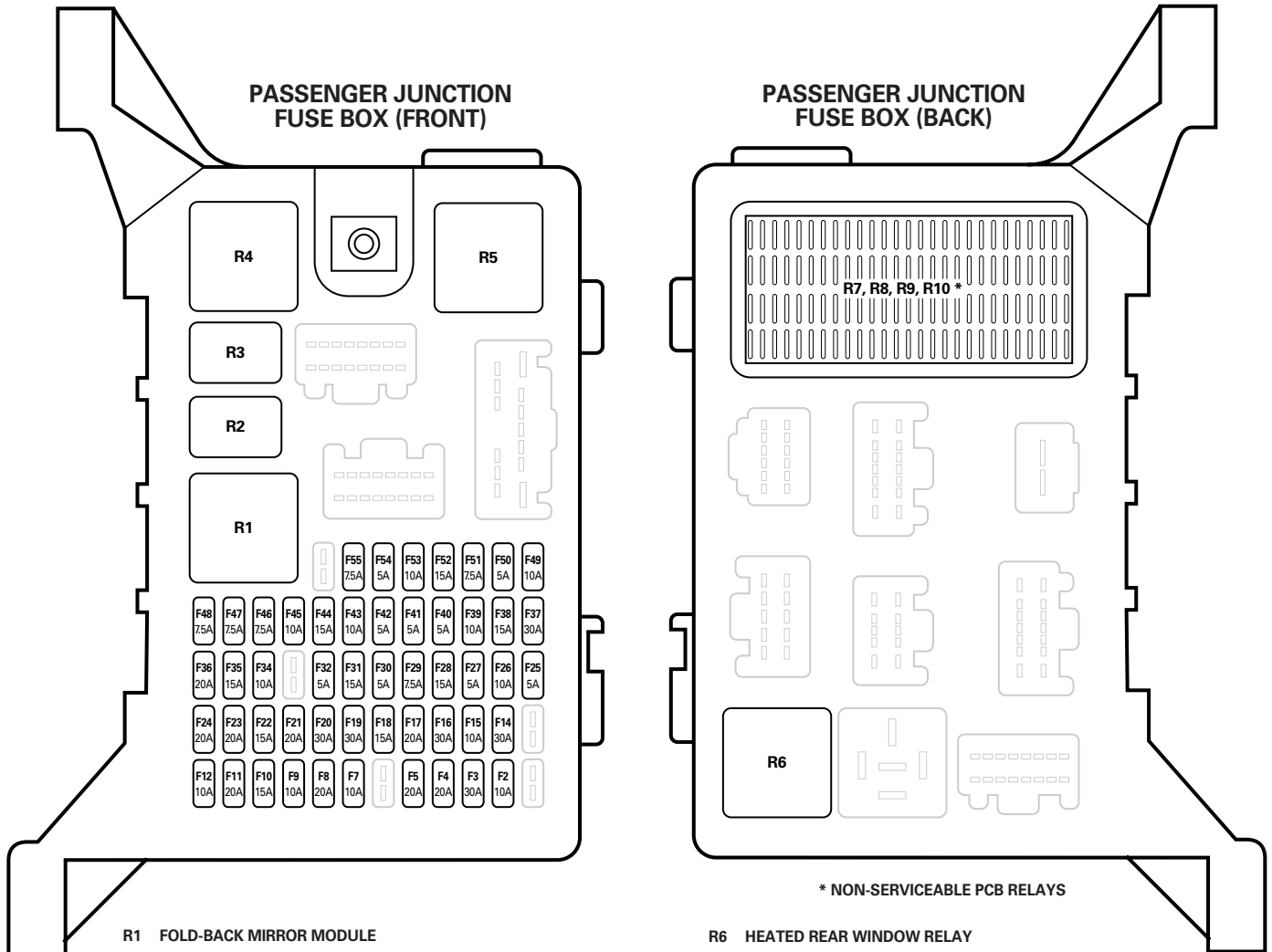

- R1 FOLD-BACK MIRROR MODULE
- R2 ACCESSORY RELAY
- R3 REAR WIPER MOTOR RELAY (SPORTS BRAKE ONLY)
- R4 BLOWER MOTOR RELAY
- R5 PASSENGER JUNCTION FUSE BOX IGNITION RELAY

- R6 HEATED REAR WINDOW RELAY
- R7 THROTTLE MOTOR RELAY (2.5L AND 3.0L VEHICLES)
FUEL PUMP RELAY (2.0L VEHICLES)
- R8 NOT USED
- R9 REVERSE LAMPS RELAY
- R10 BATTERY SAVER RELAY

* NON-SERVICEABLE PCB RELAYS



POWER DISTRIBUTION FUSE BOX (BOTTOM)

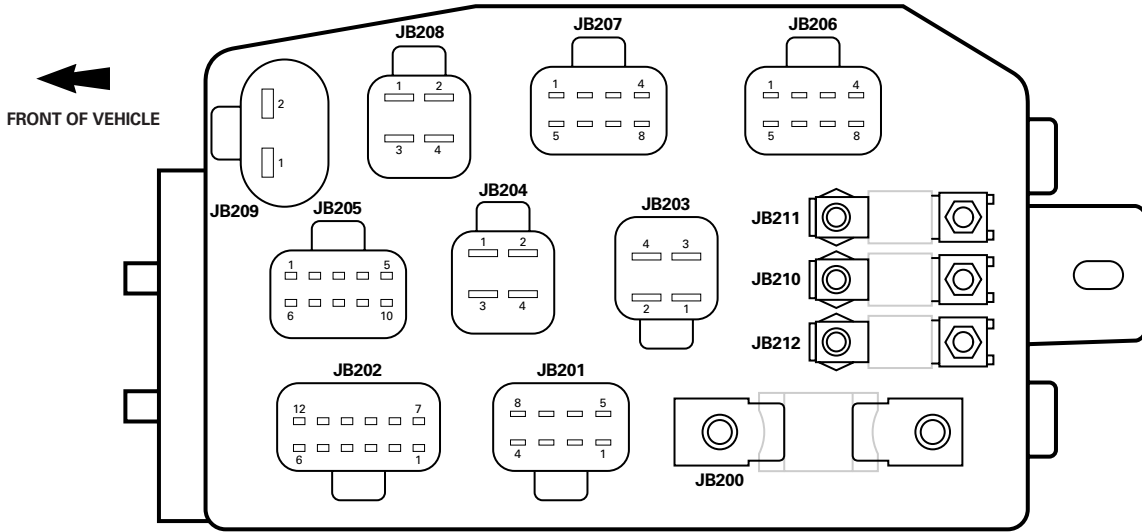

PASSENGER JUNCTION FUSE BOX (FRONT)

PASSENGER JUNCTION FUSE BOX (BACK)

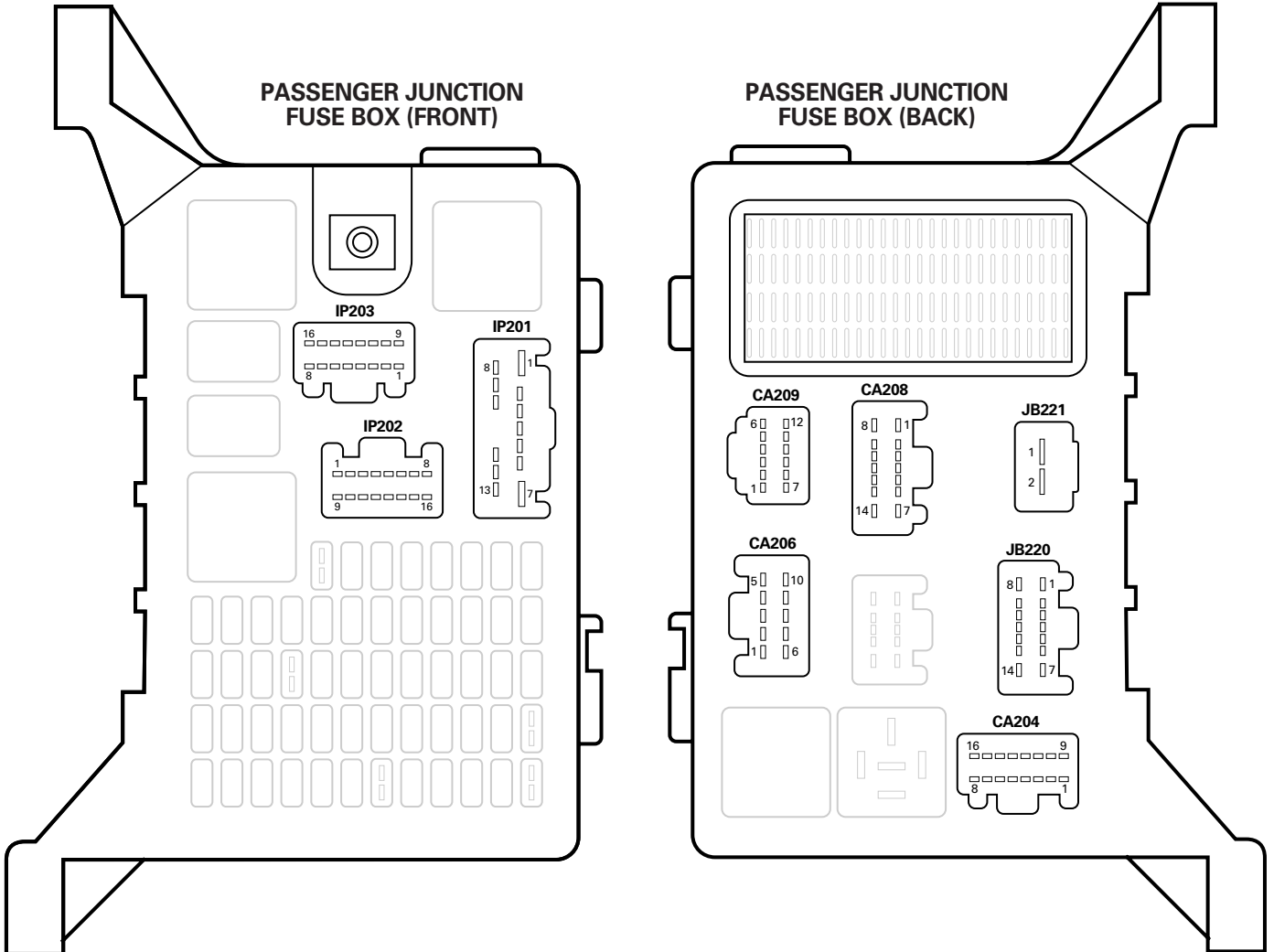



SEDAN (GASOLINE ENGINE SHOWN)

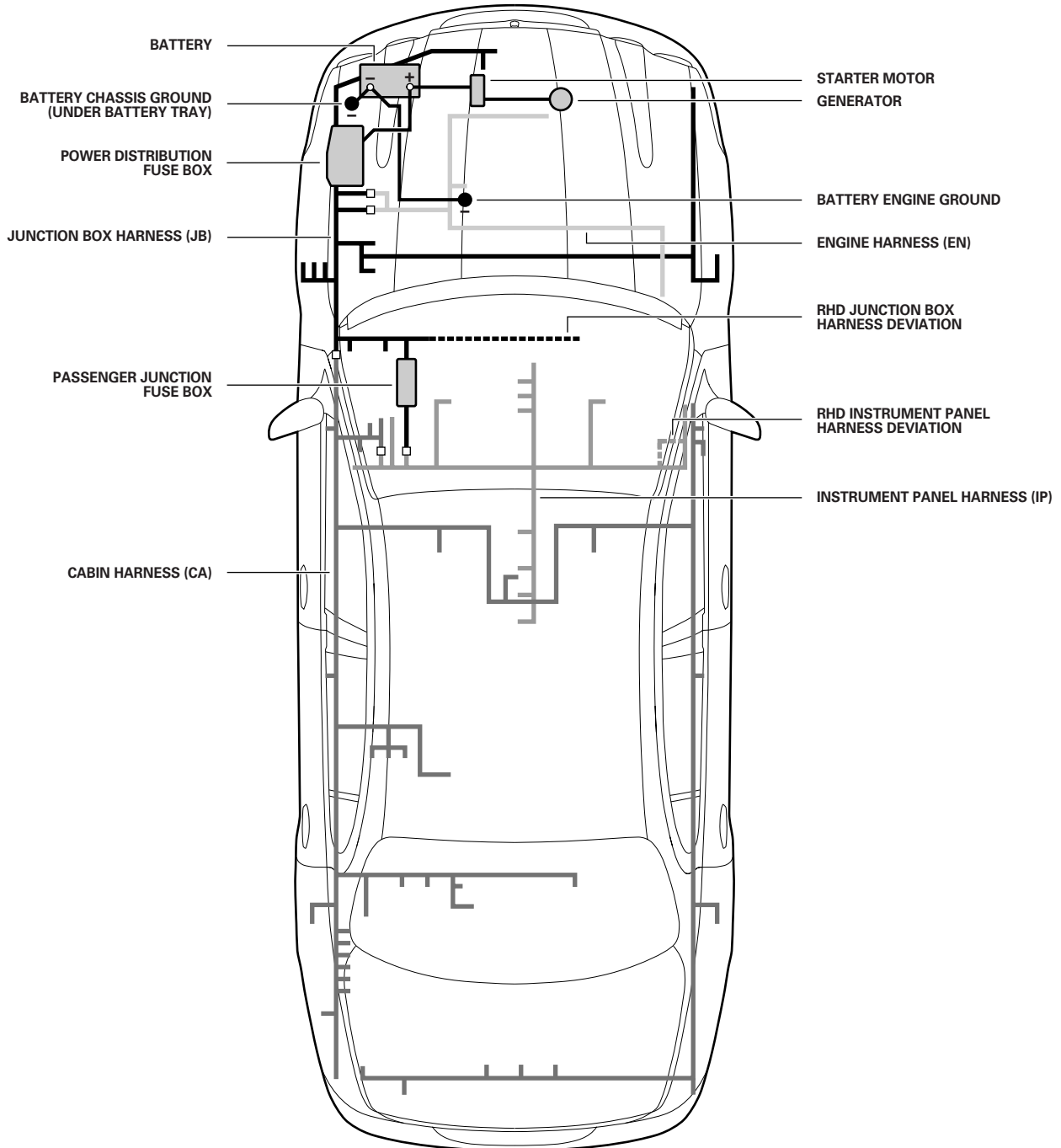



SPORTS BRAKE (GASOLINE ENGINE SHOWN)

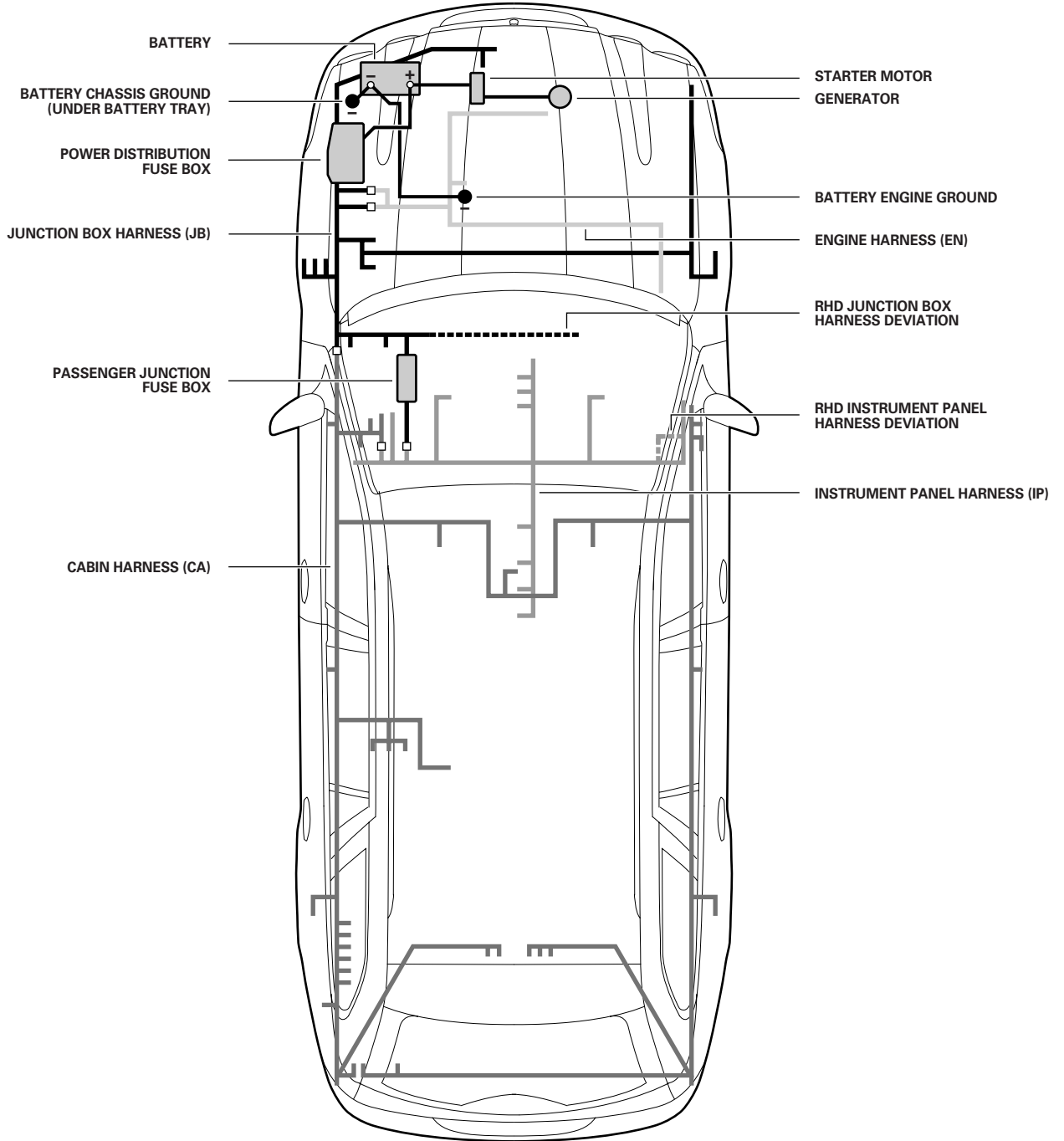



SEDAN: GASOLINE ENGINE (LHD SHOWN)

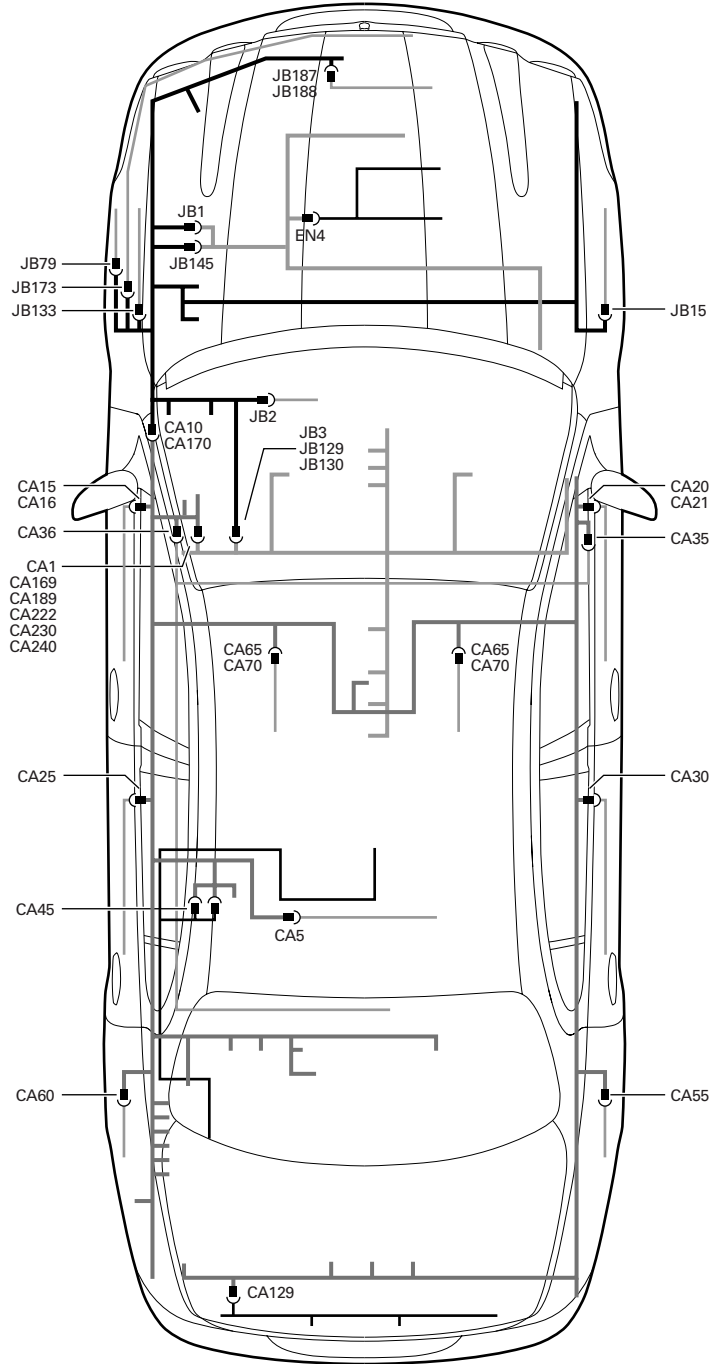



SEDAN: DIESEL ENGINE (RHD SHOWN)

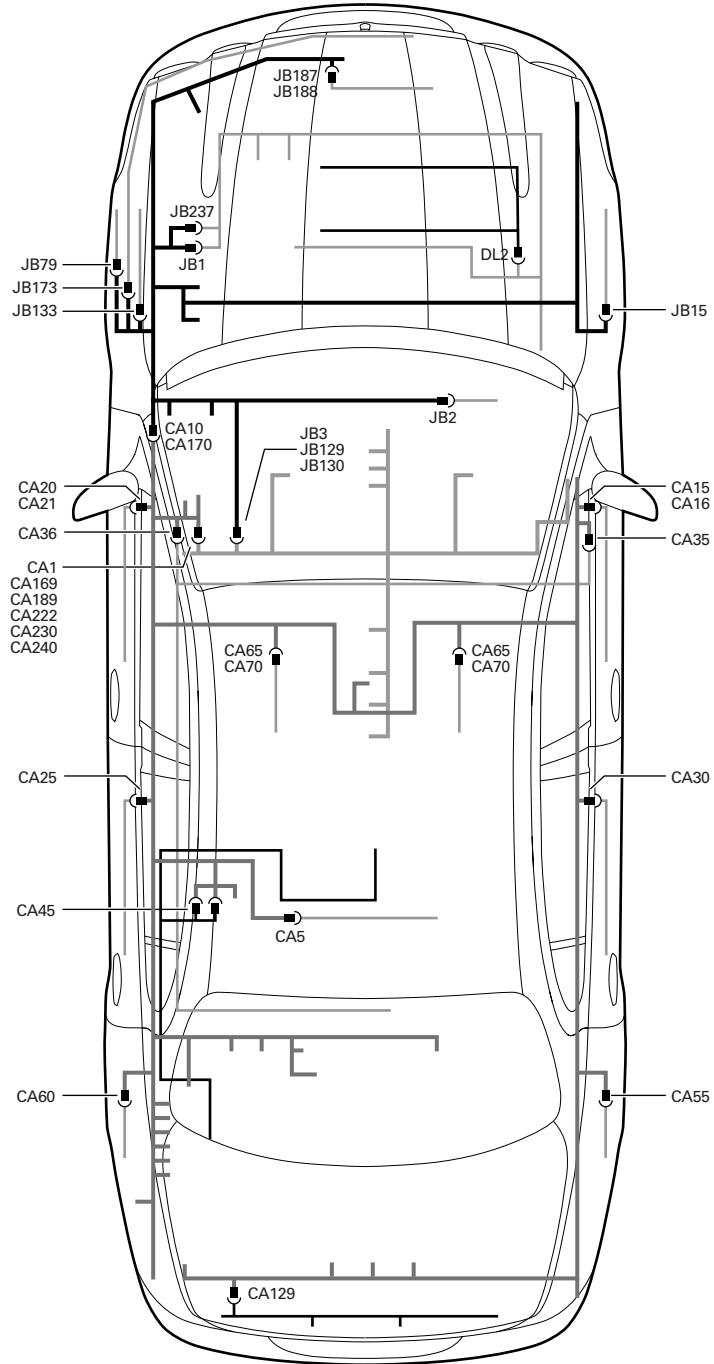



SPORTS BRAKE (RHD SHOWN)

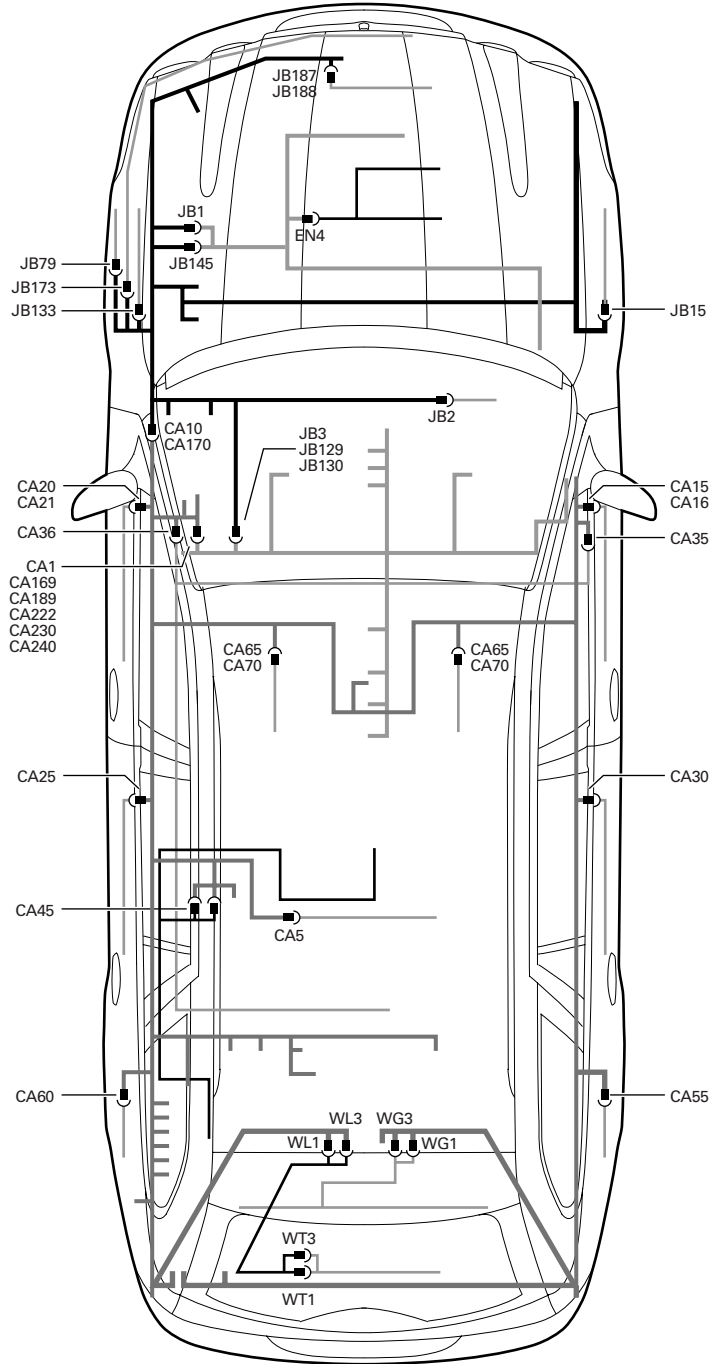



SEDAN SHOWN

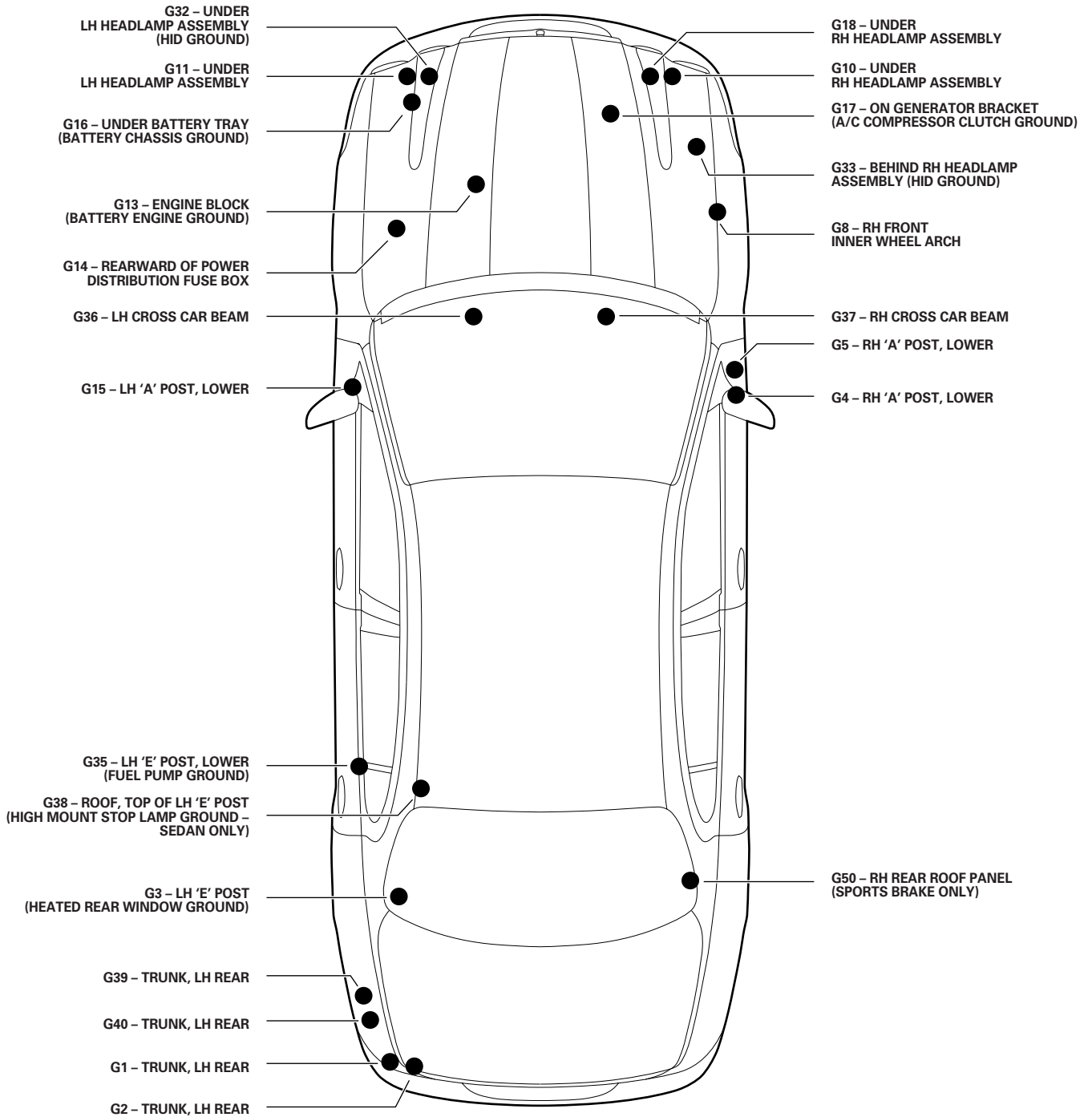

NOTE: UNIQUE GROUND STUDS ARE NOTED IN PARENTHESES.



SEDAN

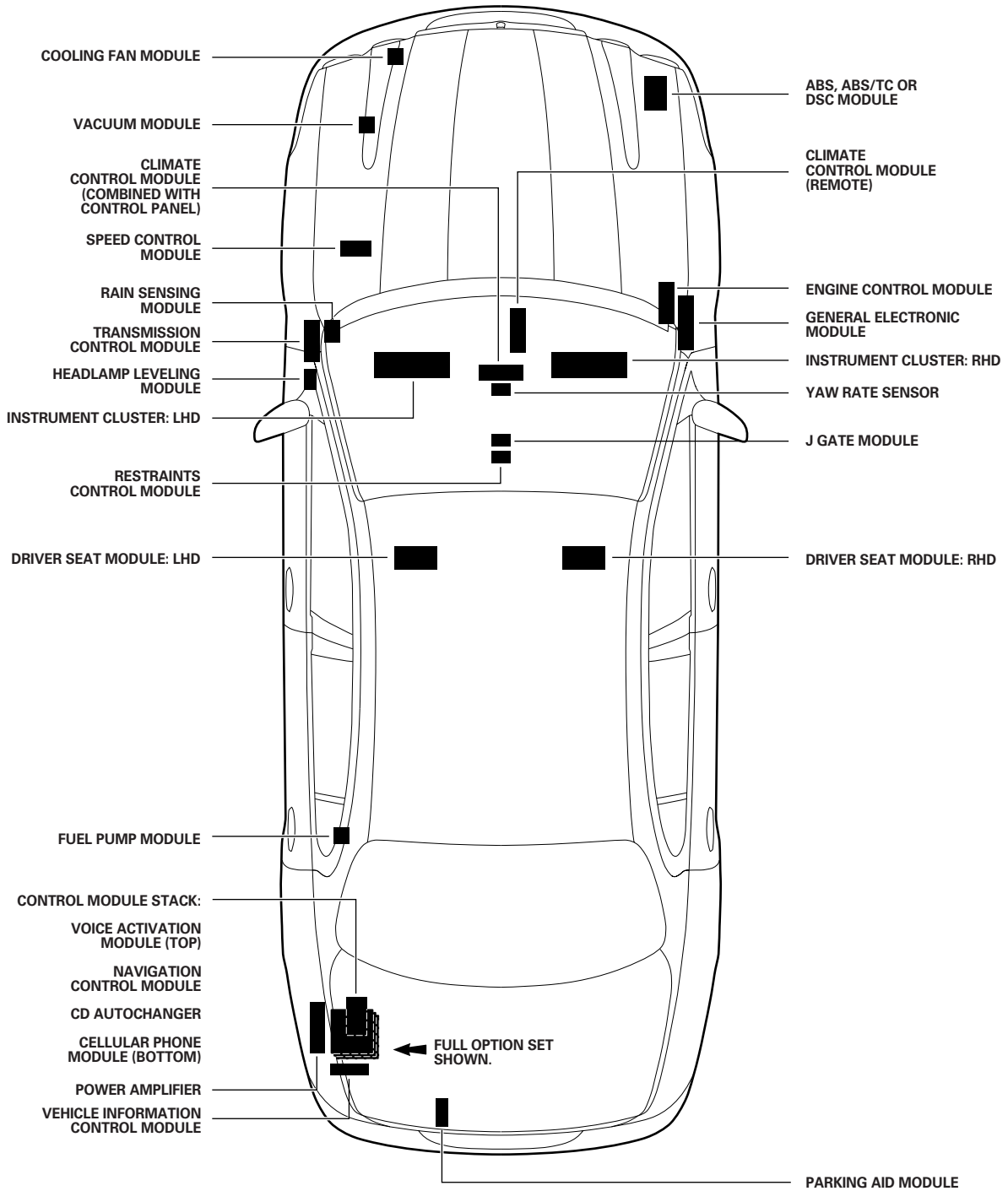



SPORTS BRAKE

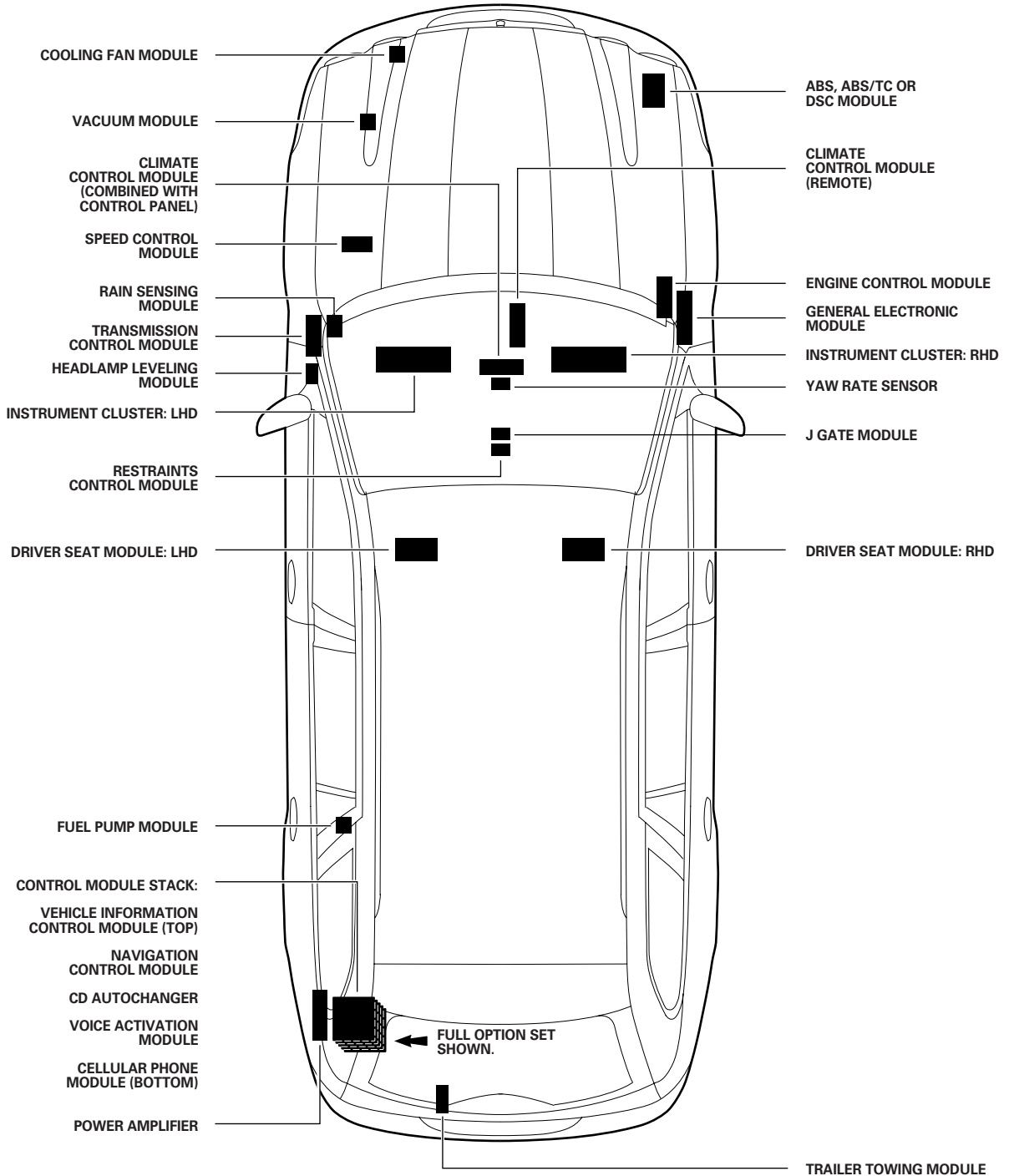

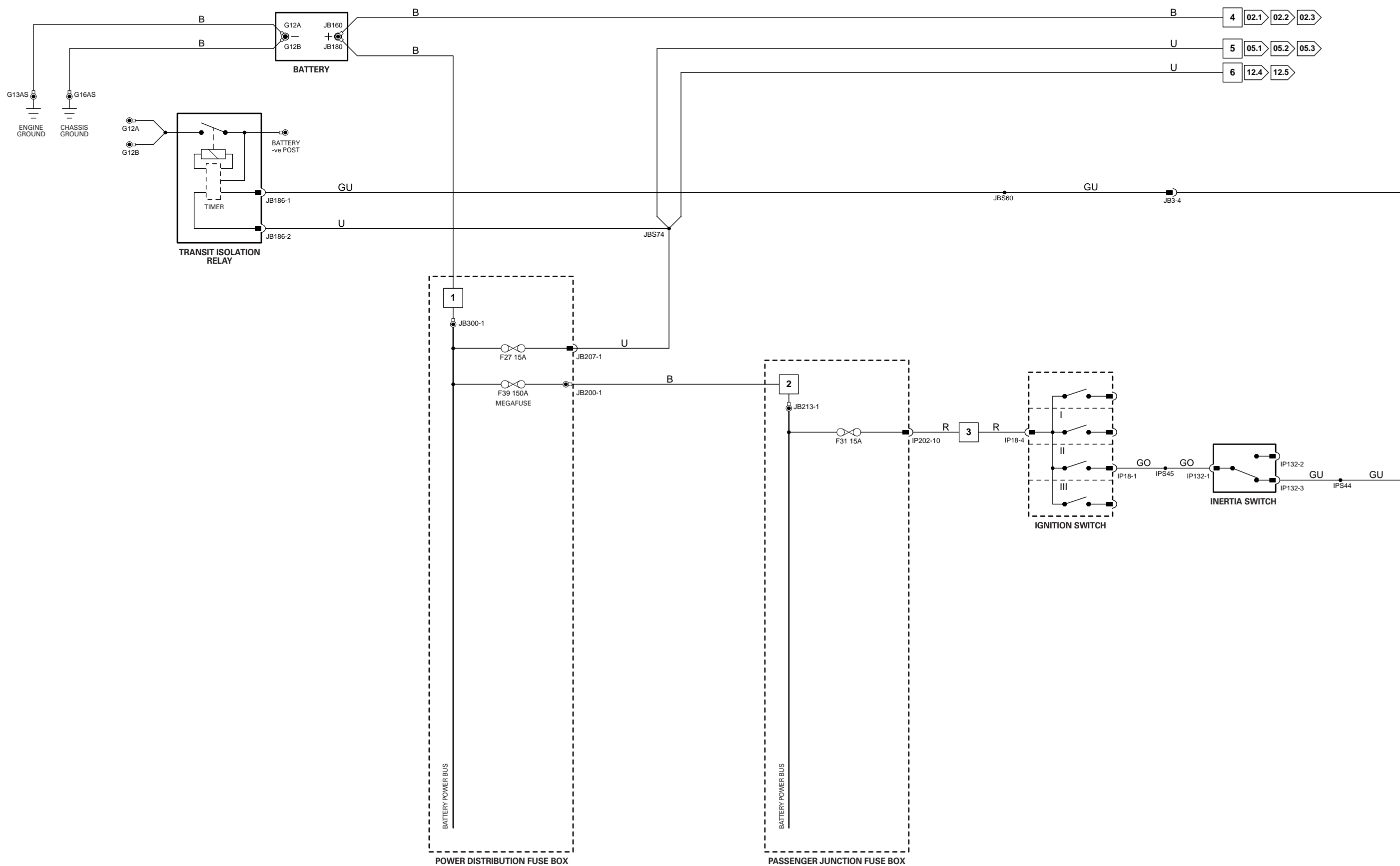

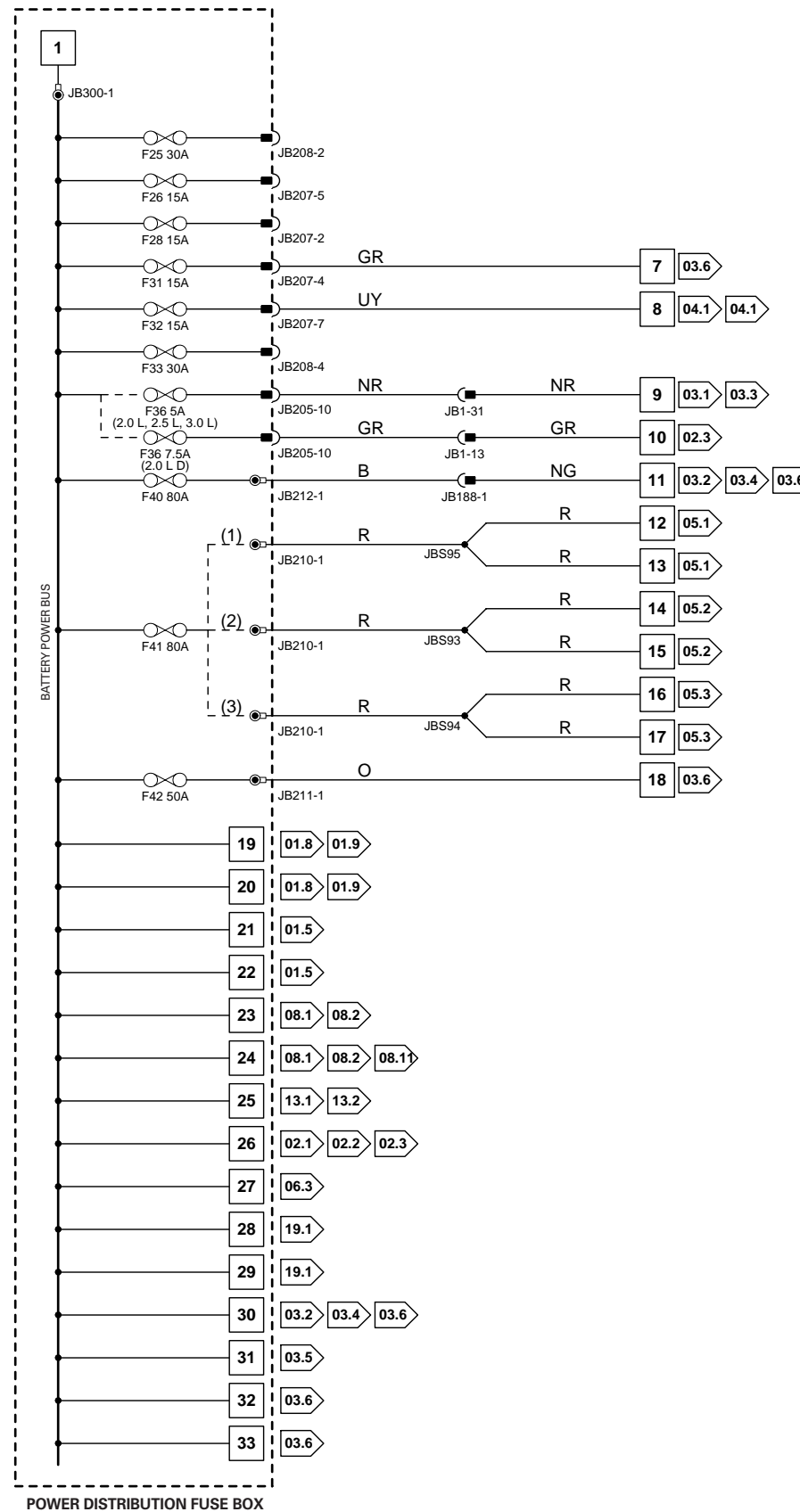

NOTATION:
 (1) Vehicles with Anti-Lock Braking only
 (2) Vehicles with ABS and Traction Control
 (3) Vehicles with Dynamic Stability Control

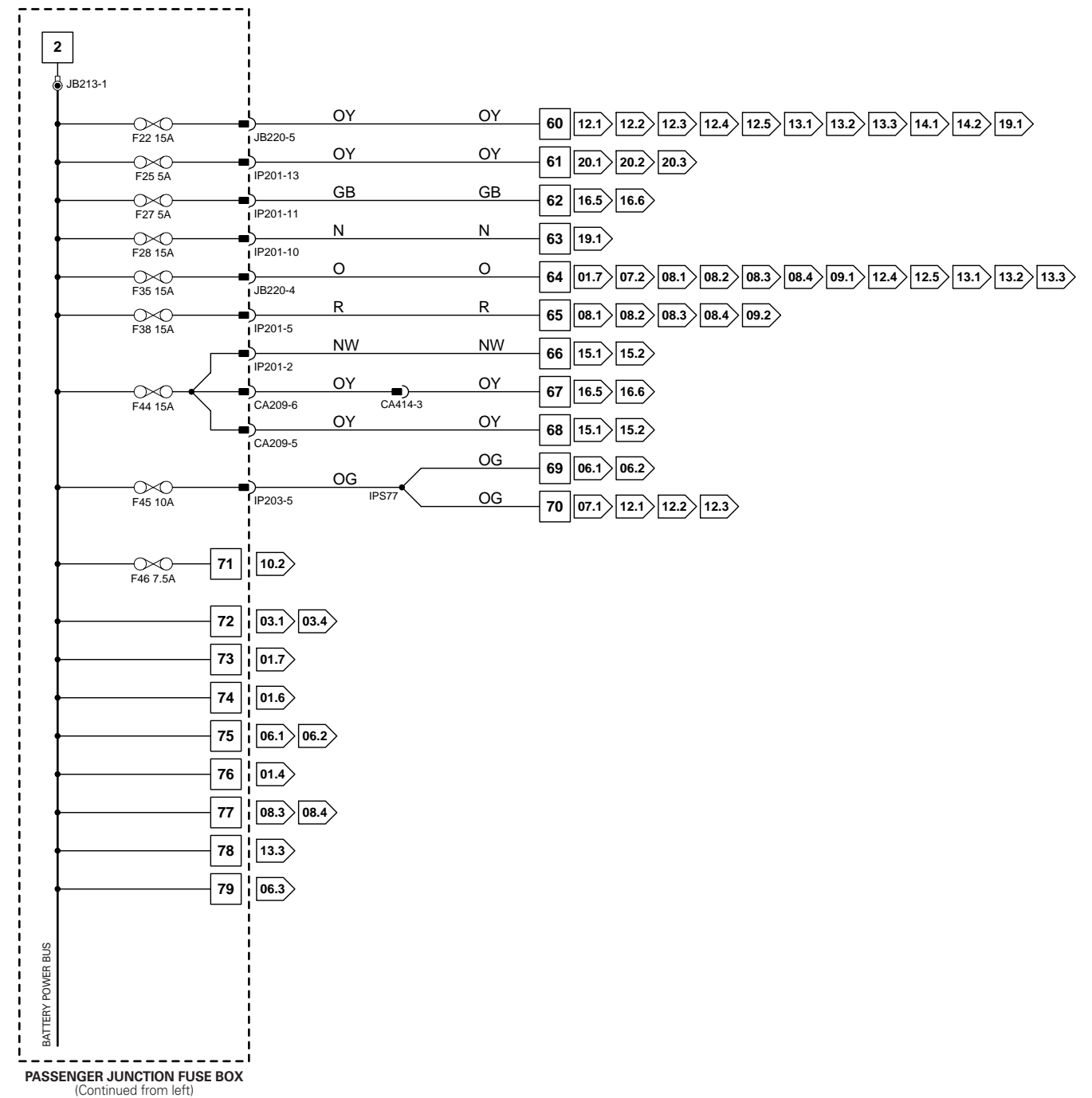
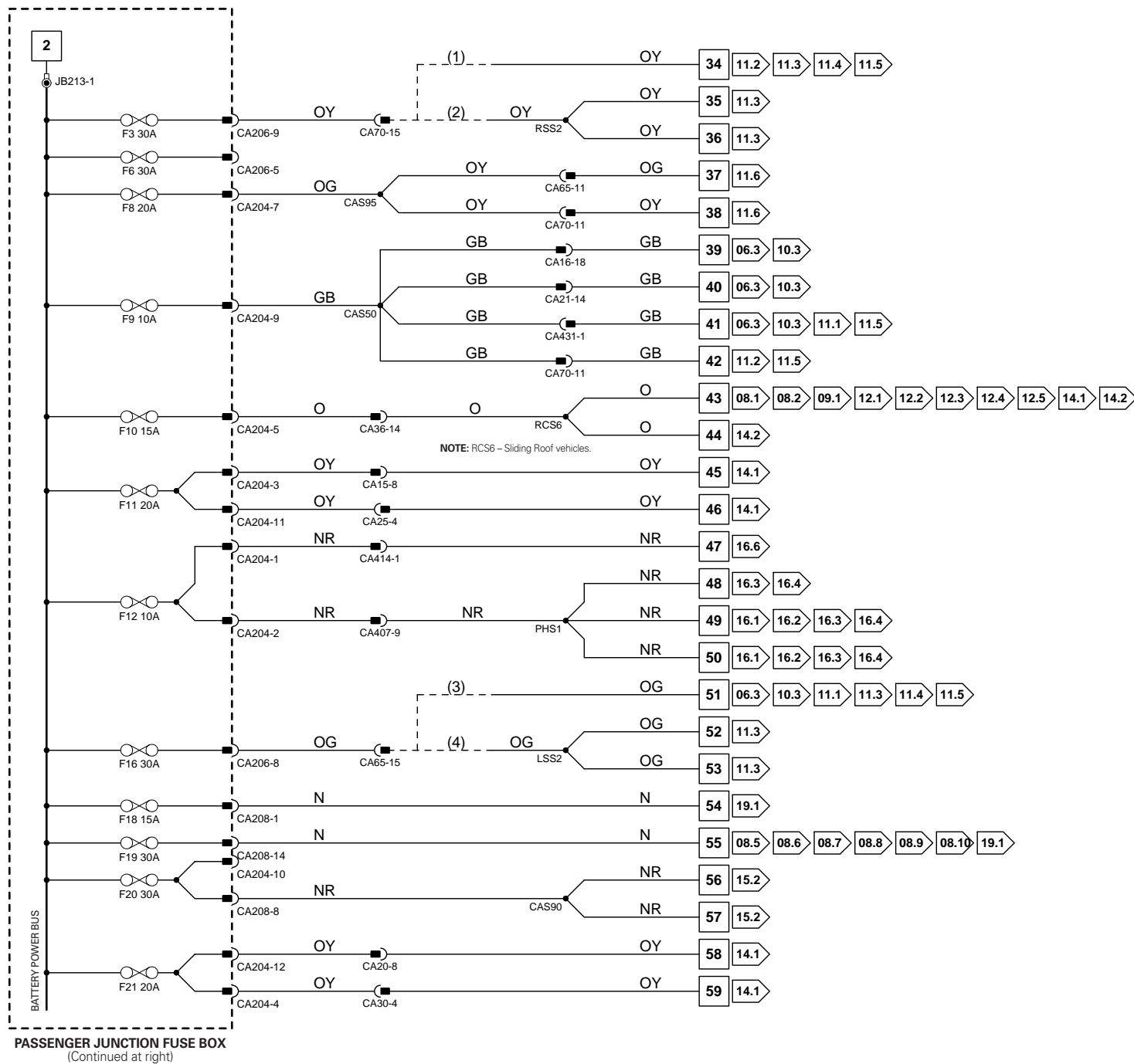

NOTATION:
 (1) Passenger Memory Seat; RH Seat without Lumbar
 (2) RH Seat with Lumbar
 (3) Driver Memory Seat; LH Seat without Lumbar
 (4) LH Seat with Lumbar

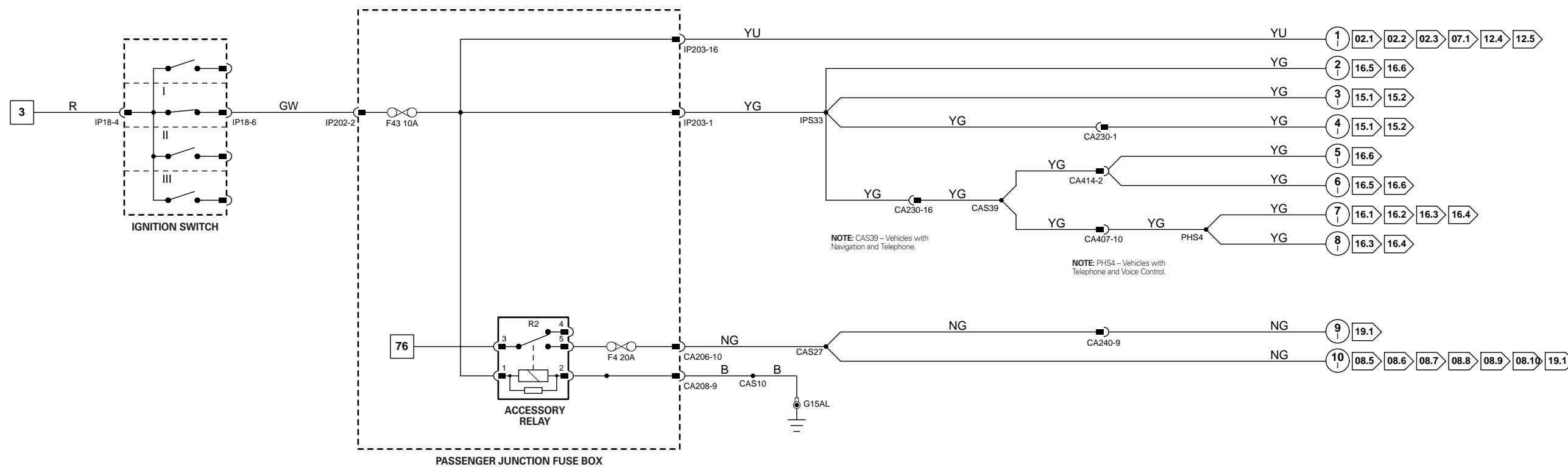

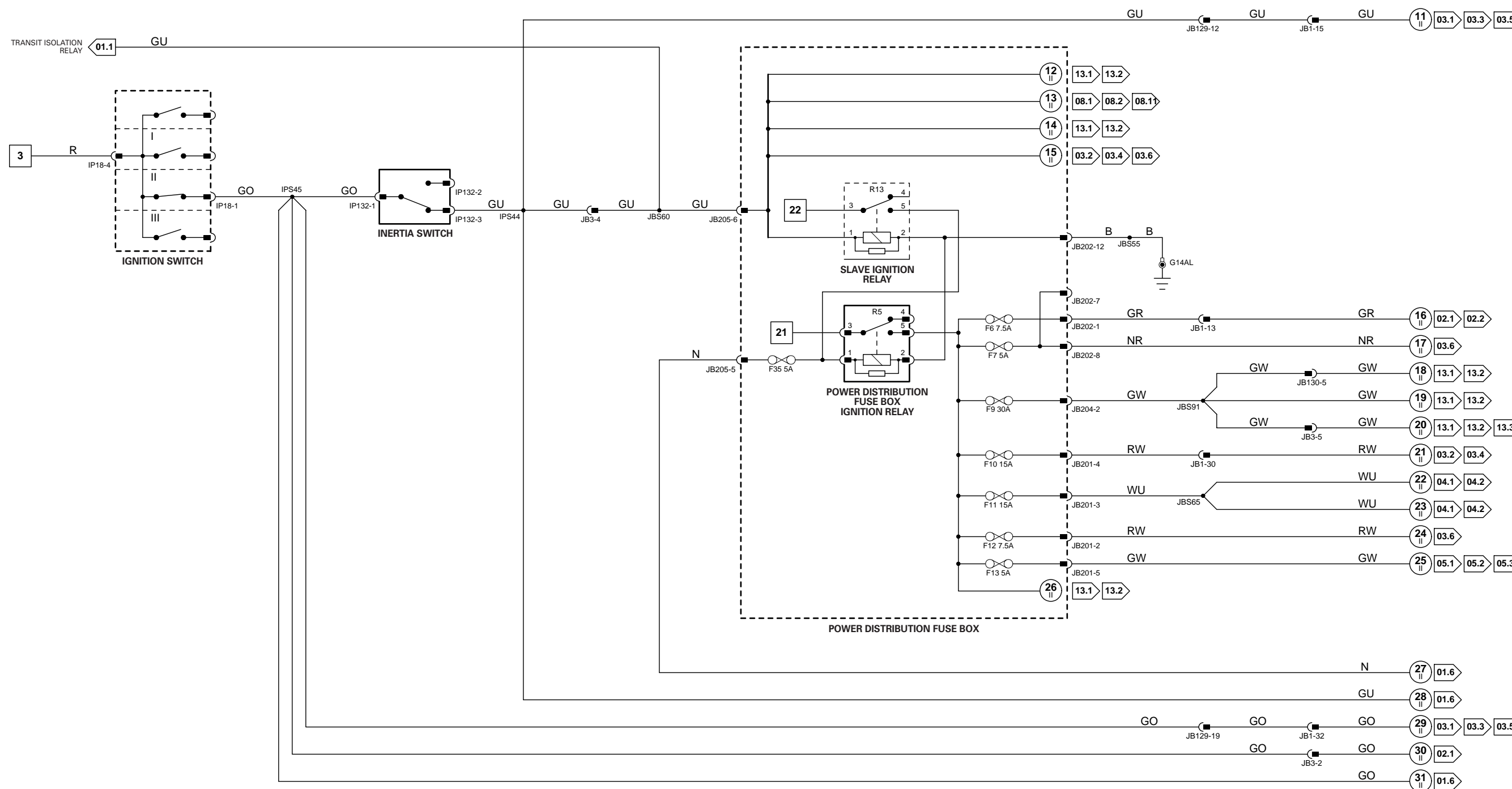

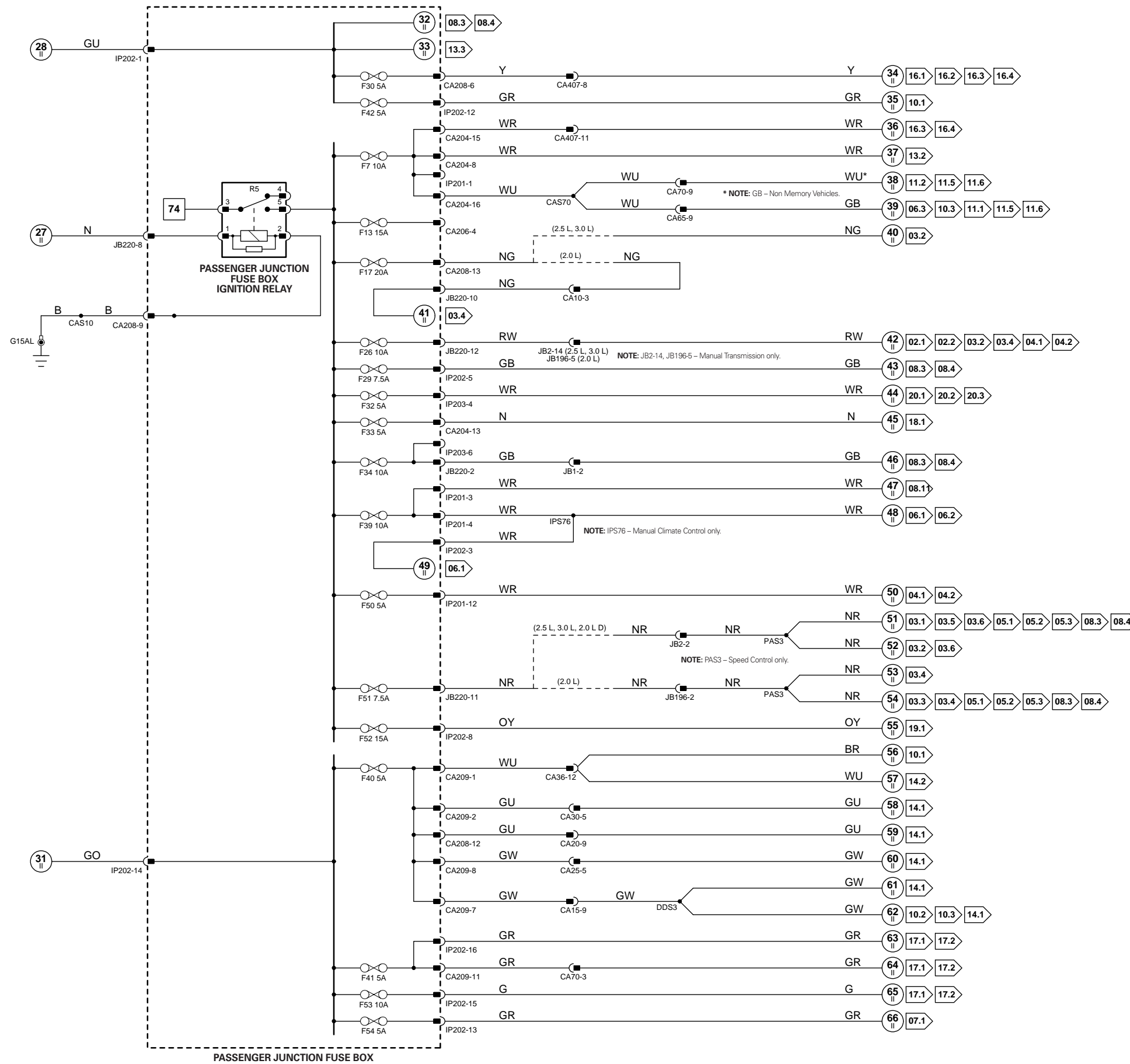

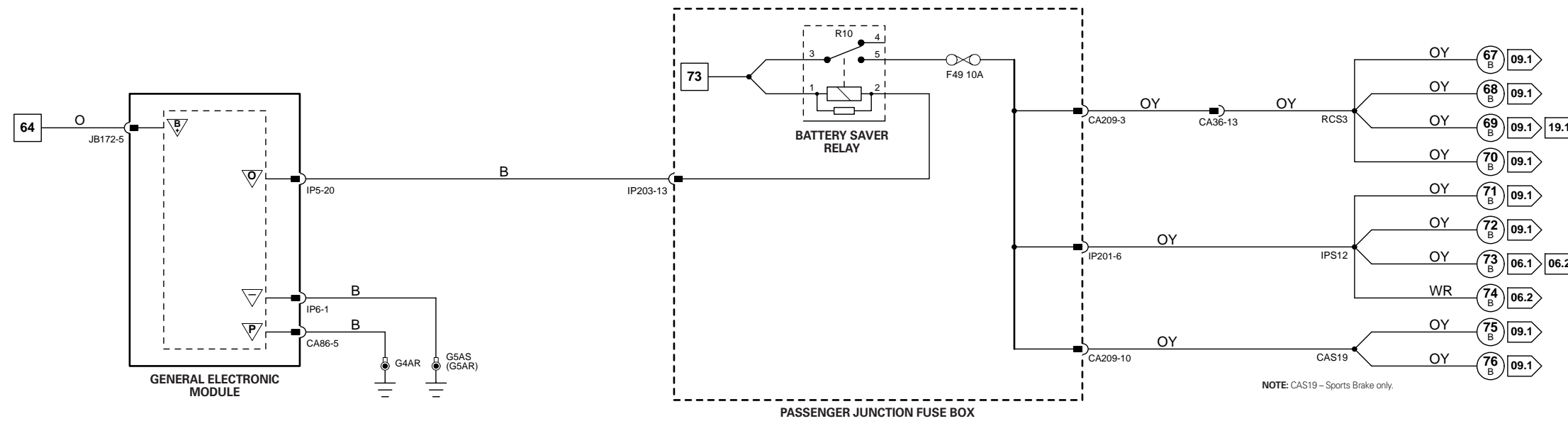

NOTE: "Battery Saver" provides automatic switch-off of the Courtesy Lamps after 10 minutes and automatic switch-off of the Demand Lighting and Audible Warning after 30 minutes.

GEM timers are started when the Ignition Key has been switched to the I (Accessory) or 0 (Off) position. When the timers expire at 10 and 30 minutes, the feature(s) is/are switched off.

When one of the following actions is detected, all features are enabled, and the Battery Saver timer is reset:

- The Ignition is switched to II (run) or III (start).
- Any door or trunk lid becomes ajar or is opened.
- Any unlock is activated.

Battery Saver is also active when GEM diagnostic mode is entered.

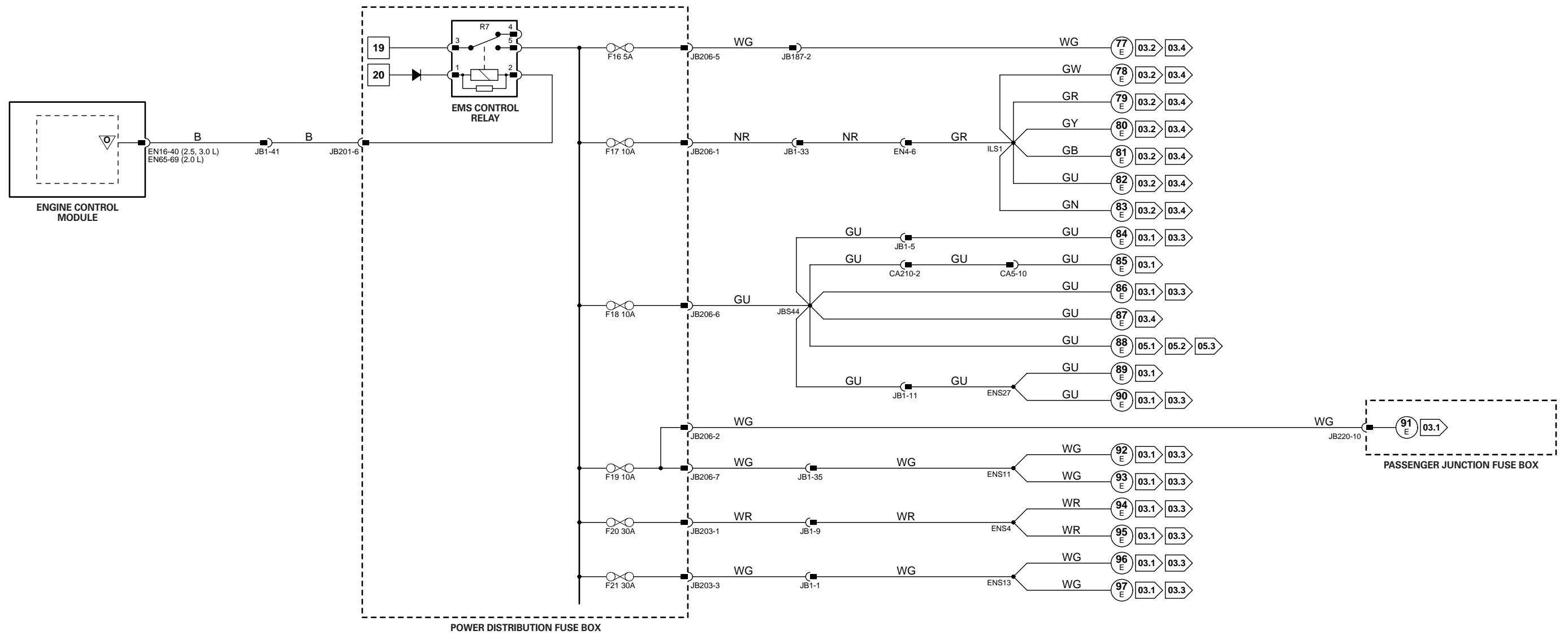

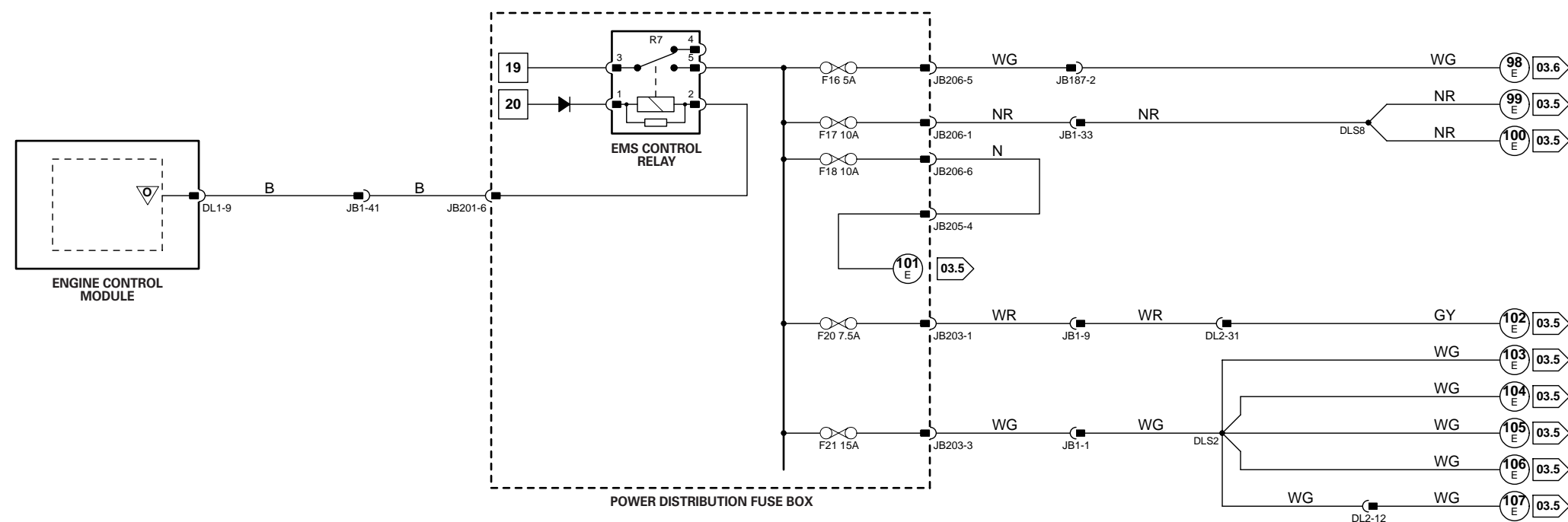

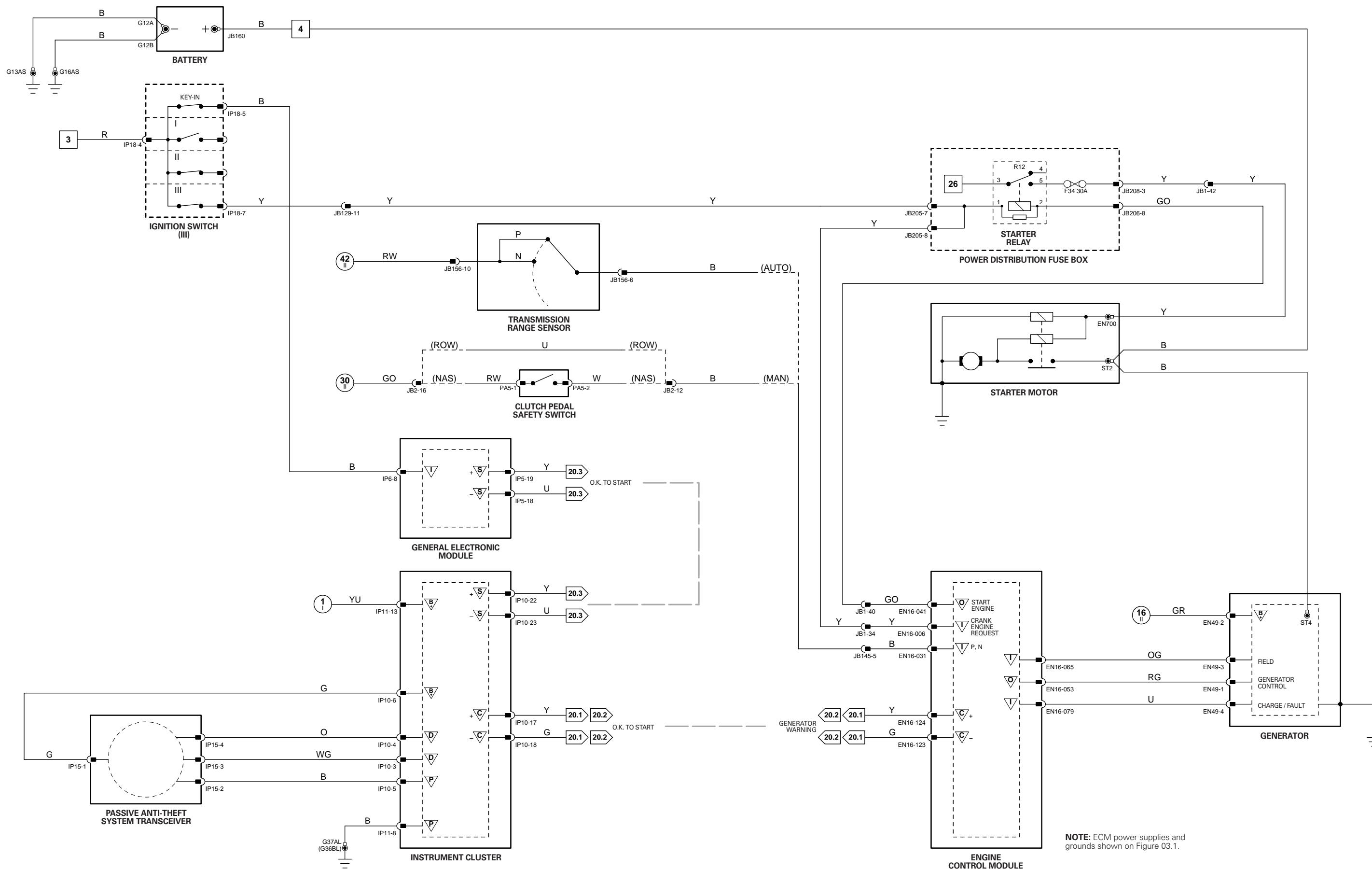

NOTE: ECM power supplies and grounds shown on Figure 03.1.

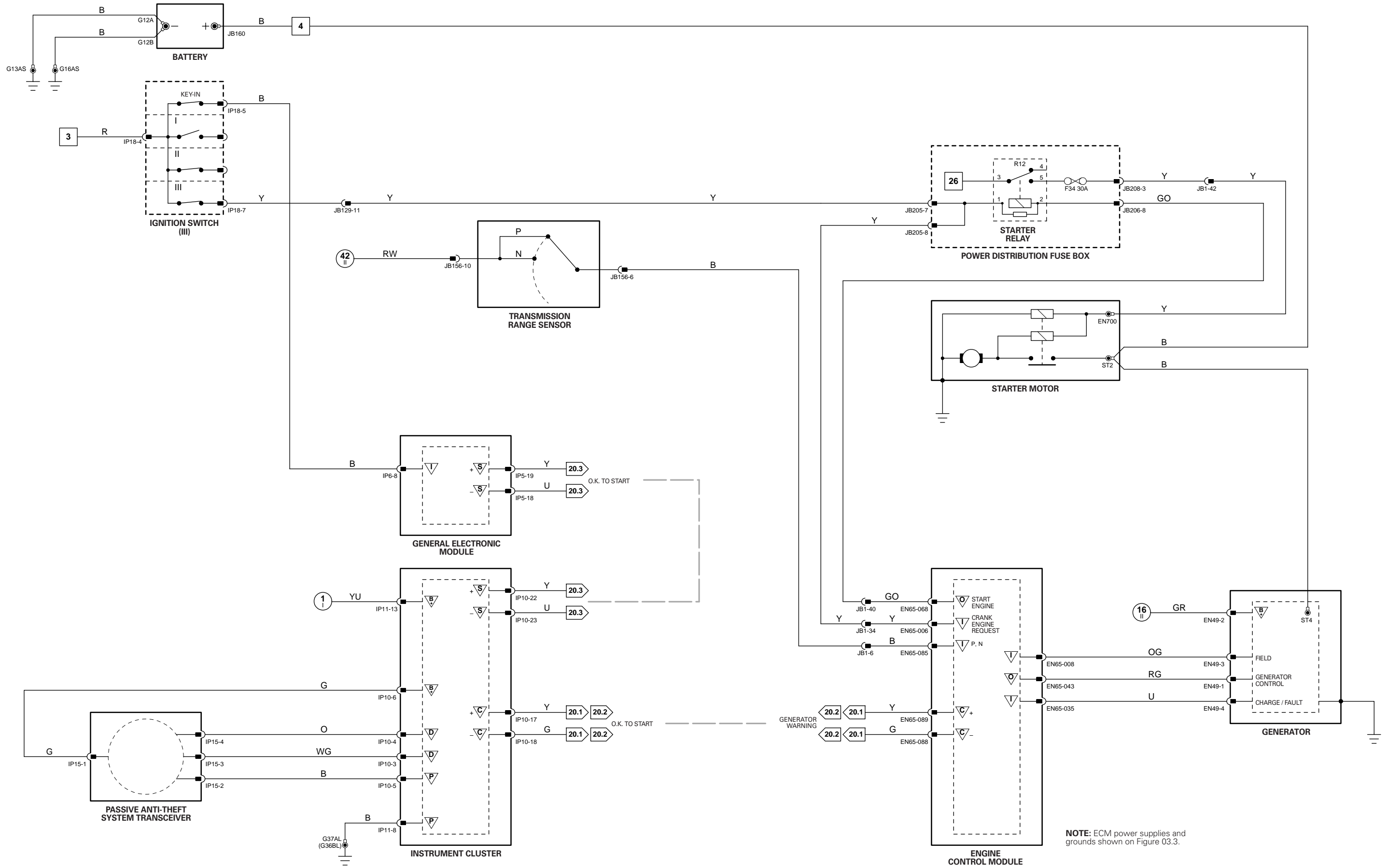

NOTE: ECM power supplies and grounds shown on Figure 03.3.

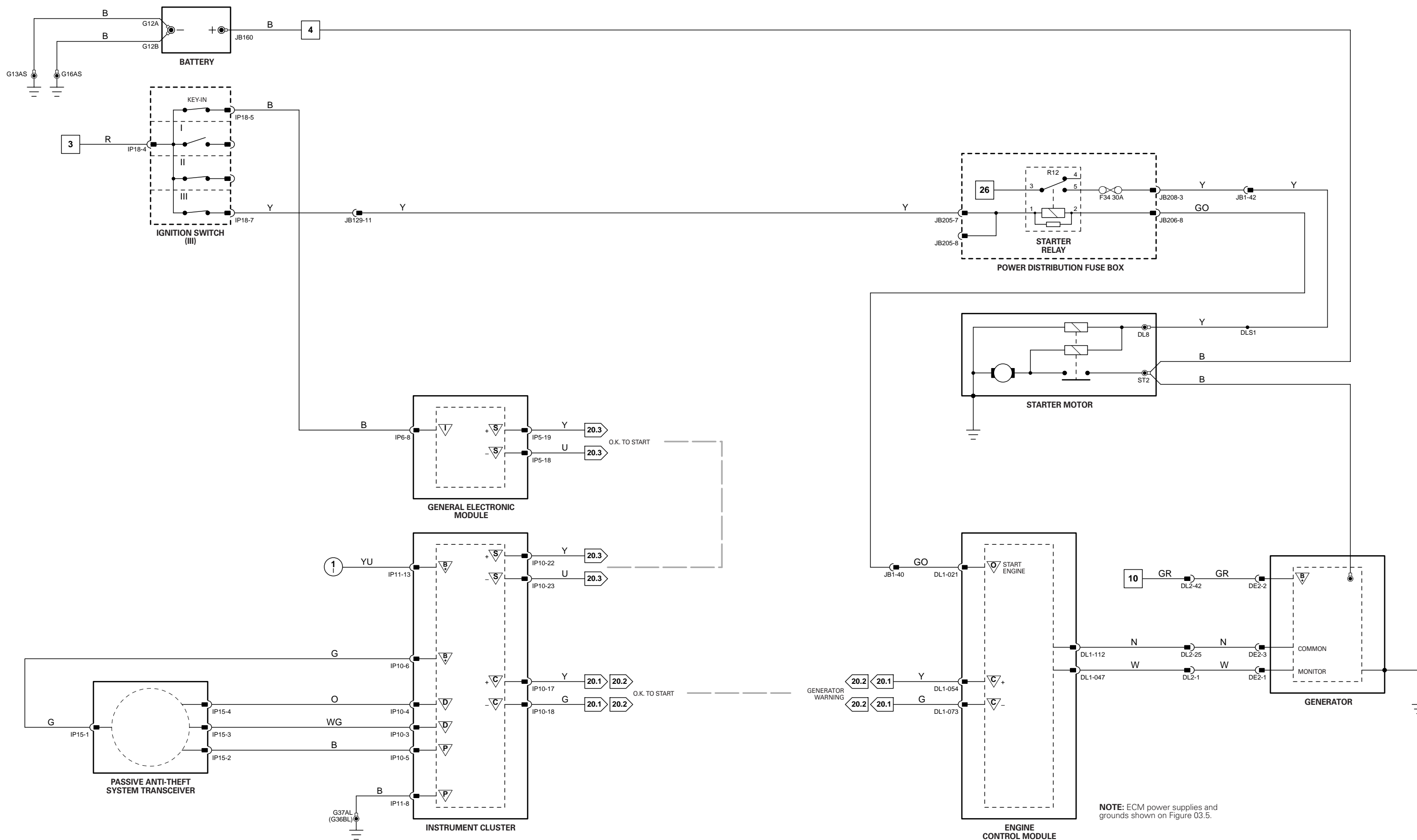

NOTE: ECM power supplies and grounds shown on Figure 03.5.

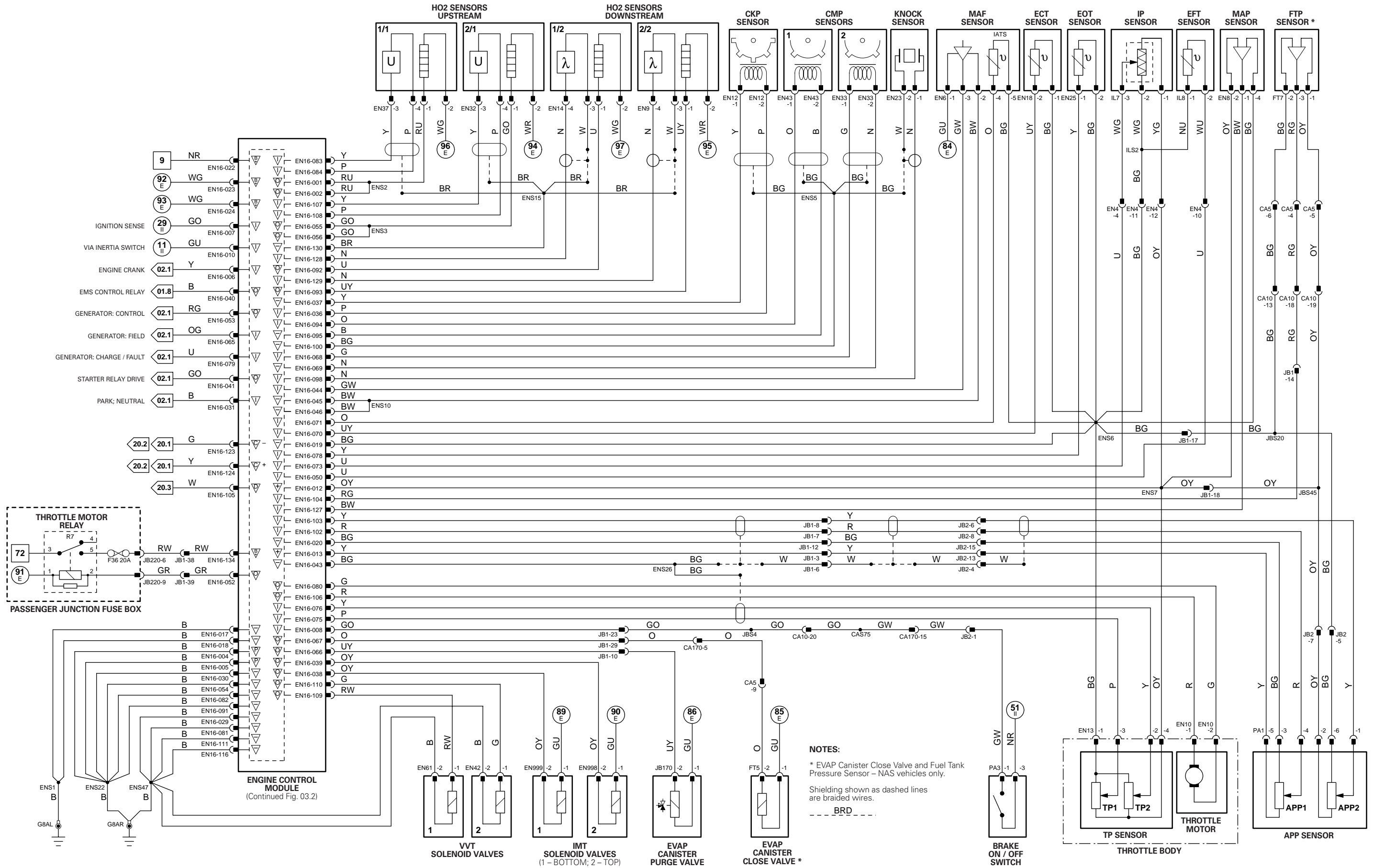

NOTES:
 * EVAP Canister Close Valve and Fuel Tank Pressure Sensor – NAS vehicles only.
 Shielding shown as dashed lines are braided wires.
 --- BRD ---

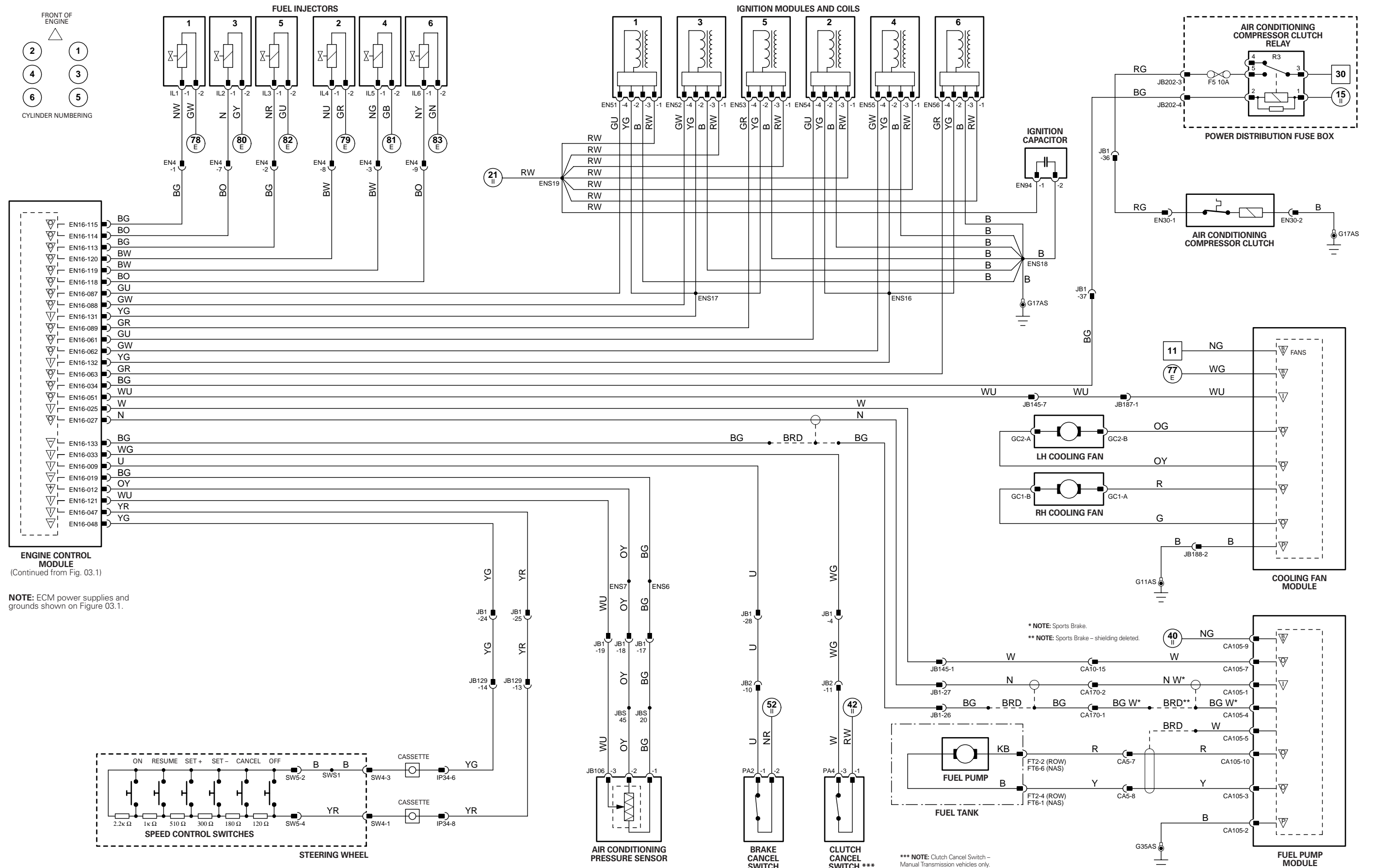

(Continued from Fig. 03.1)

NOTE: ECM power supplies and grounds shown on Figure 03.1.

* NOTE: Sports Brake.
** NOTE: Sports Brake – shielding deleted.

*** NOTE: Clutch Cancel Switch – Manual Transmission vehicles only.

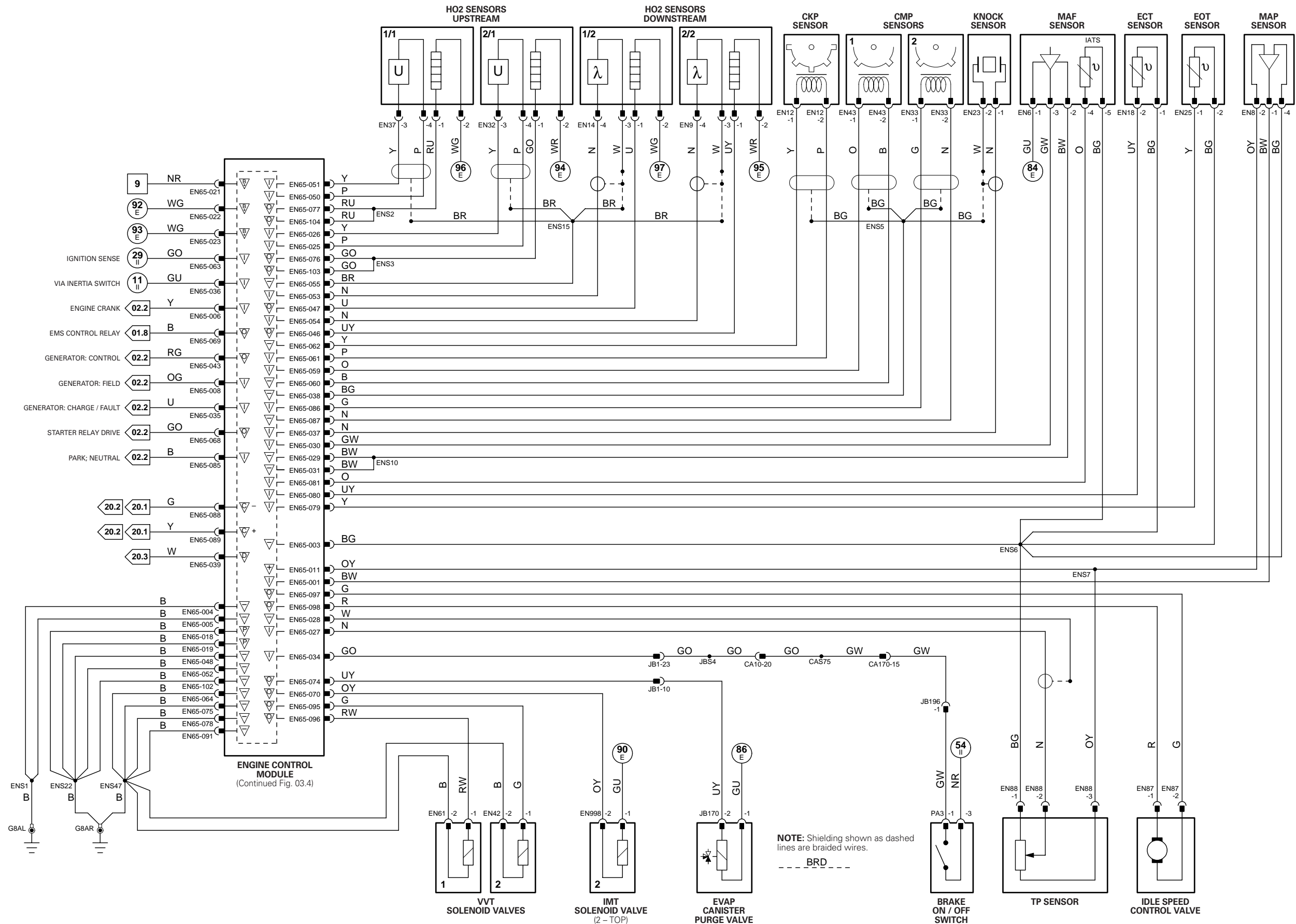

NOTE: Shielding shown as dashed lines are braided wires.
 --- BRD ---

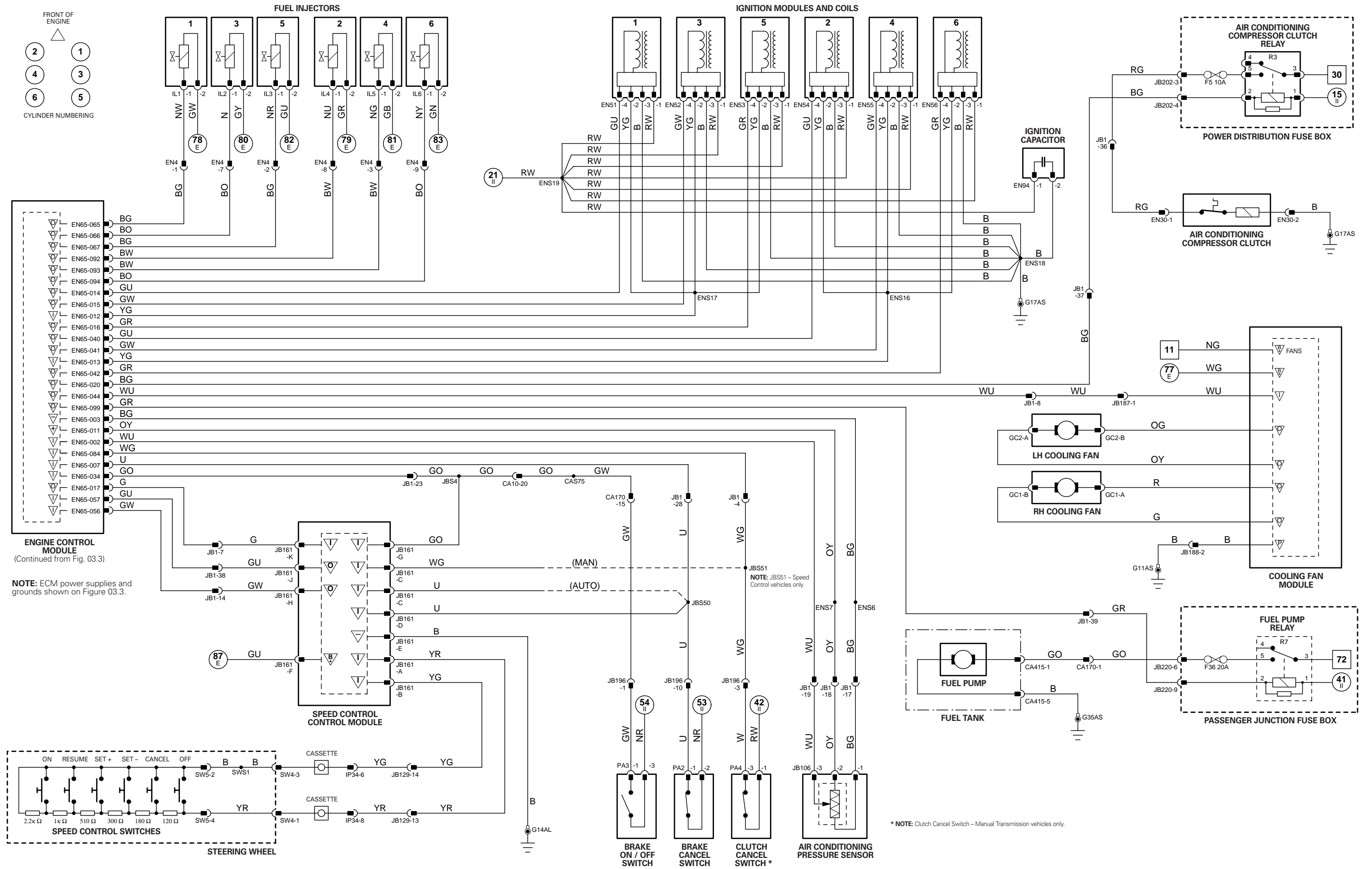

1 → 6 Fig. 01.1	34 → 79 Fig. 01.3	11 → 31 Fig. 01.5	67 → 76 Fig. 01.7	98 → 107 Fig. 01.9	▽ Input	Ⓟ Battery Voltage	▽ Sensor/Signal Supply V	△ CAN	Ⓞ D2B Network
7 → 33 Fig. 01.2	1 → 10 Fig. 01.4	32 → 66 Fig. 01.6	77 → 97 Fig. 01.8		○ Output	Ⓟ Power Ground	▽ Sensor/Signal Ground	△ SCP	Ⓞ Serial and Encoded Data

VARIANT: 2.0 L Gasoline Engine Vehicles
VIN RANGE: All
DATE OF ISSUE: June 2003 (PROVISIONAL)

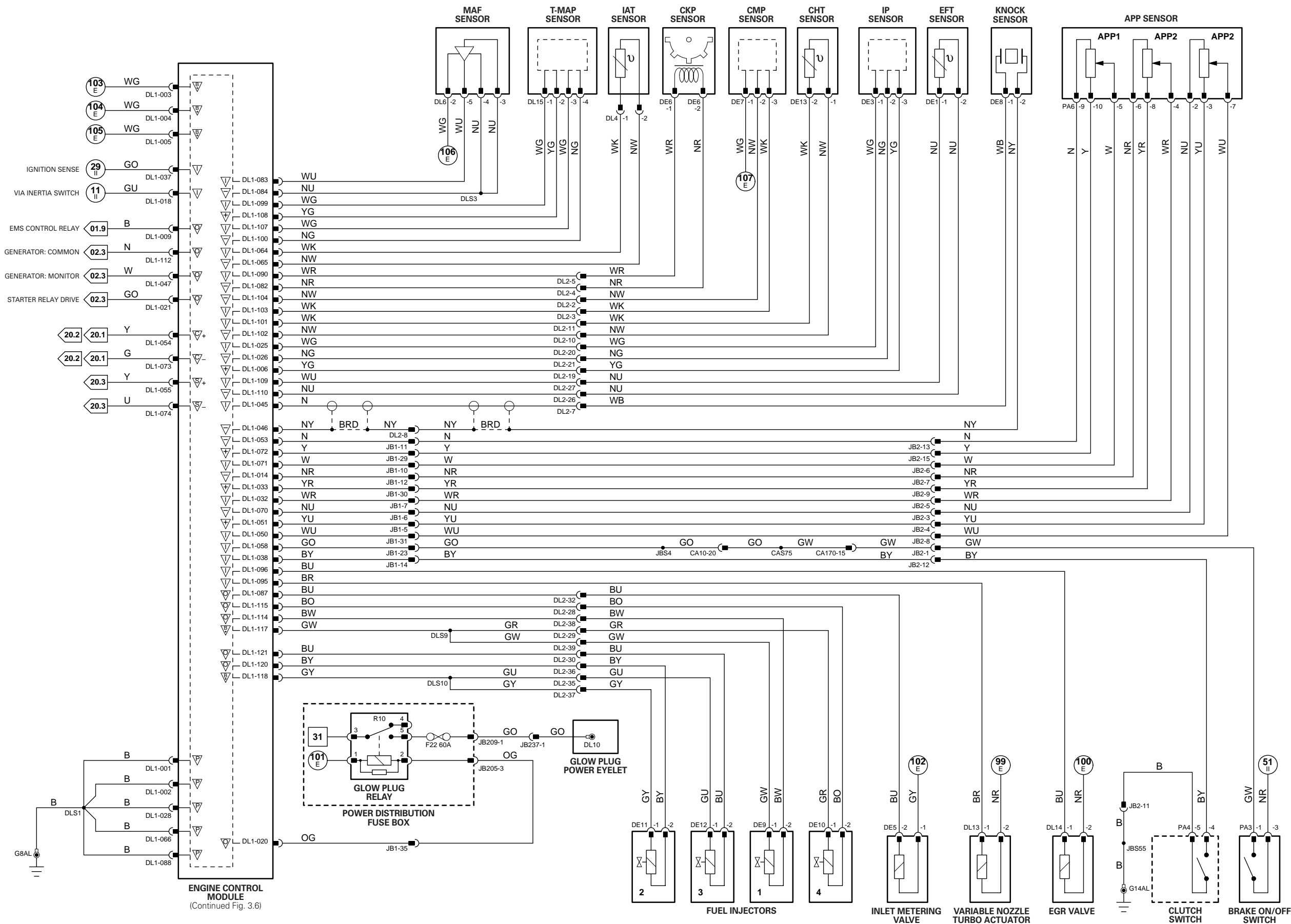

1 → 6	Fig. 01.1	34 → 79	Fig. 01.3	11 → 31	Fig. 01.5	67 → 76	Fig. 01.7	98 → 107	Fig. 01.9	▽	Input	B	Battery Voltage	▽	Sensor/Signal Supply V	△	CAN	S	D2B Network
7 → 33	Fig. 01.2	1 → 10	Fig. 01.4	32 → 66	Fig. 01.6	77 → 97	Fig. 01.8			○	Output	P	Power Ground	▽	Sensor/Signal Ground	C	SCP	D	Serial and Encoded Data

VARIANT: 2.0 L Diesel Engine Vehicles
 VIN RANGE: All
 DATE OF ISSUE: June 2003 (PROVISIONAL)



* NOTE: Either Fuel-Fired Auxiliary Heater or Electric Auxiliary Heater fitted.

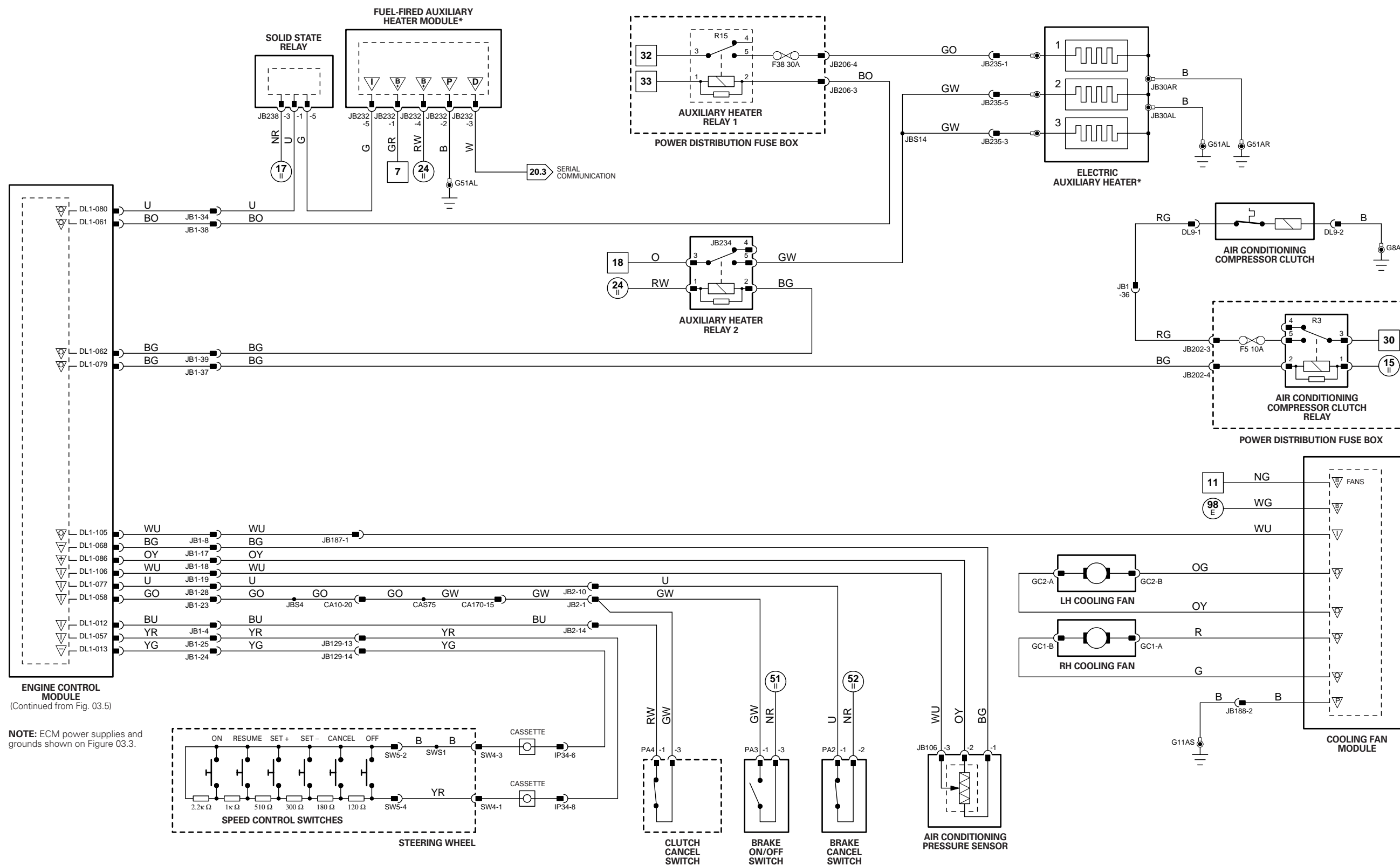

ENGINE CONTROL MODULE (Continued from Fig. 03.5)

NOTE: ECM power supplies and grounds shown on Figure 03.3.

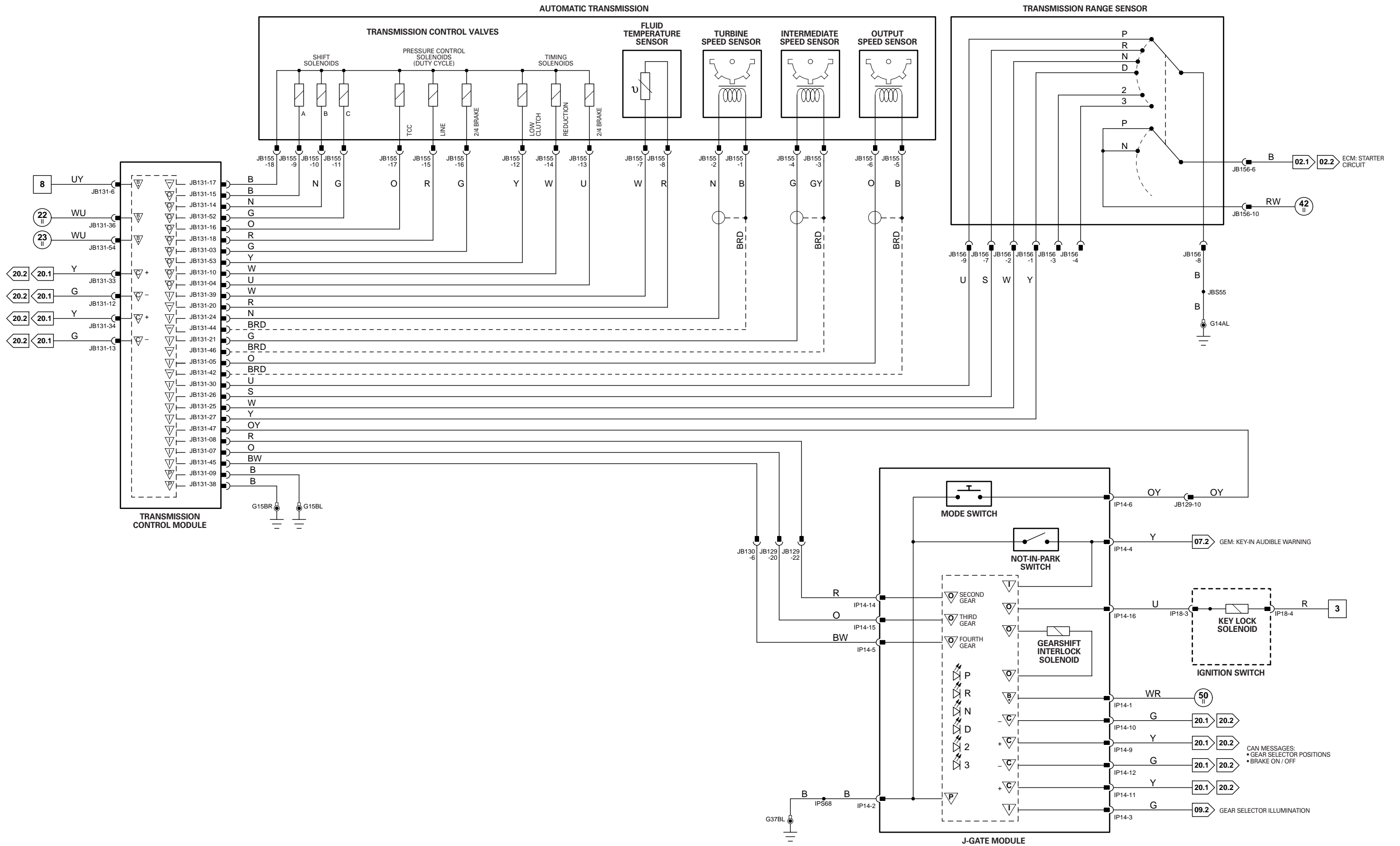

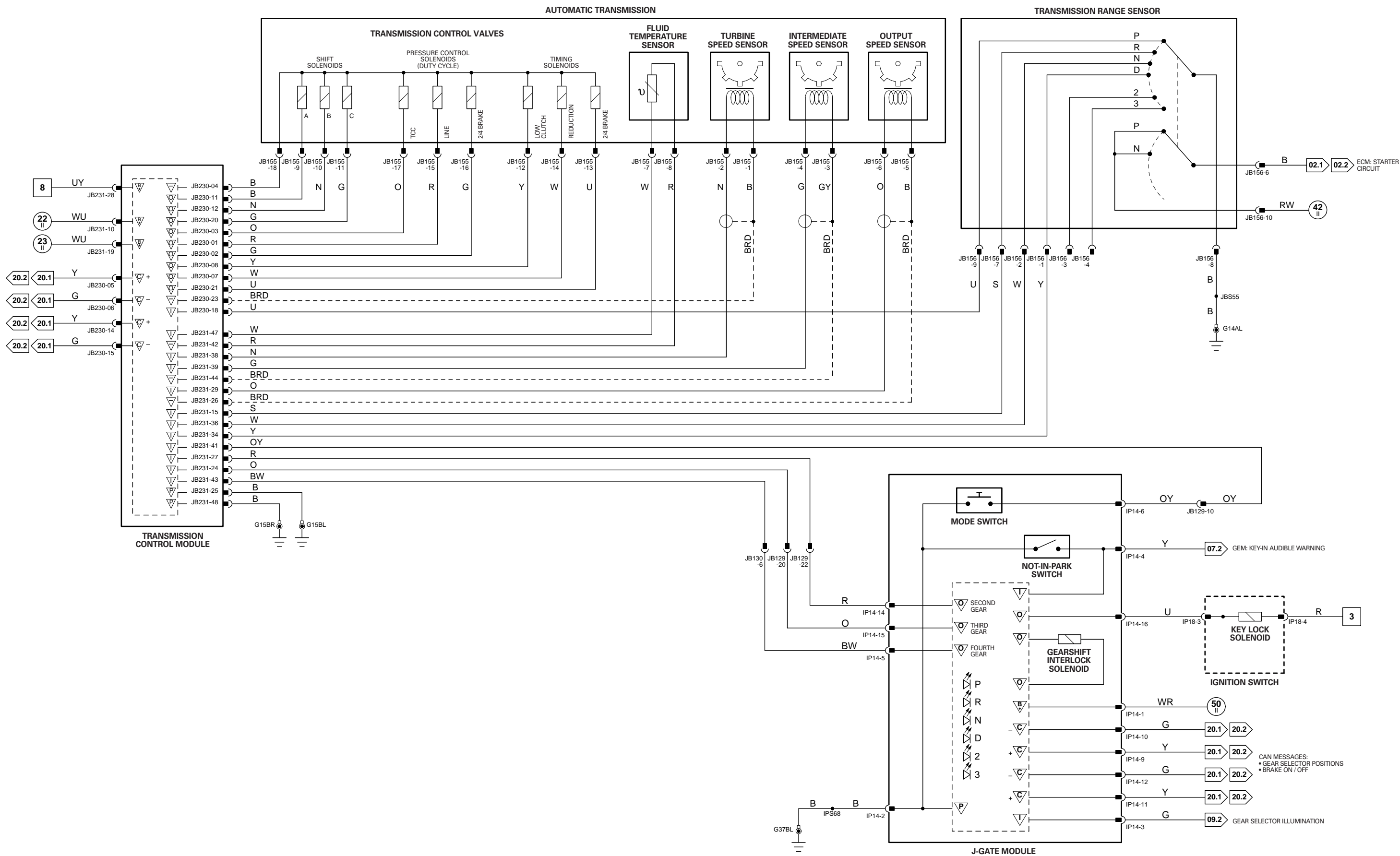

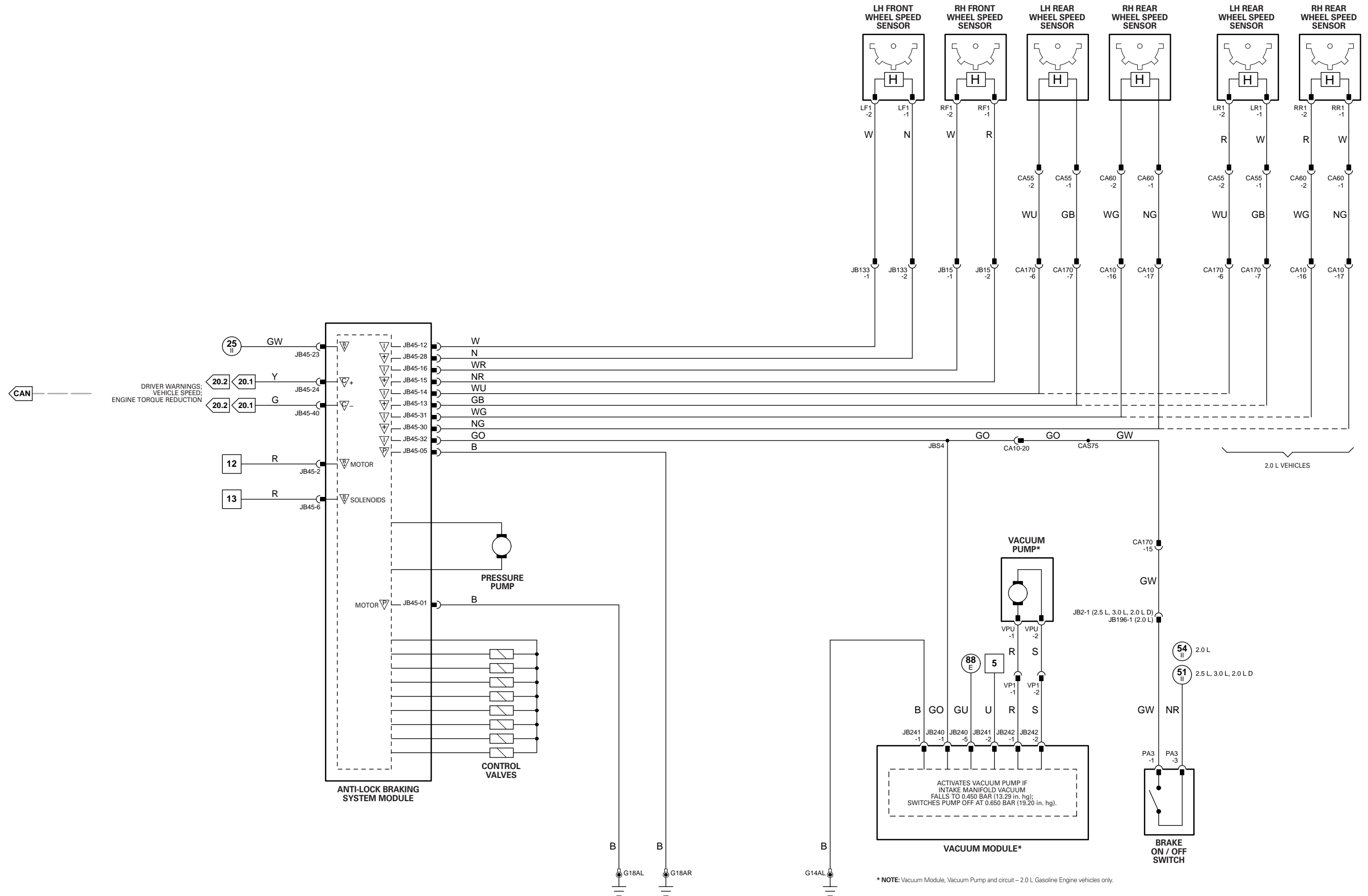

* NOTE: Vacuum Module, Vacuum Pump and circuit - 2.0 L Gasoline Engine vehicles only.

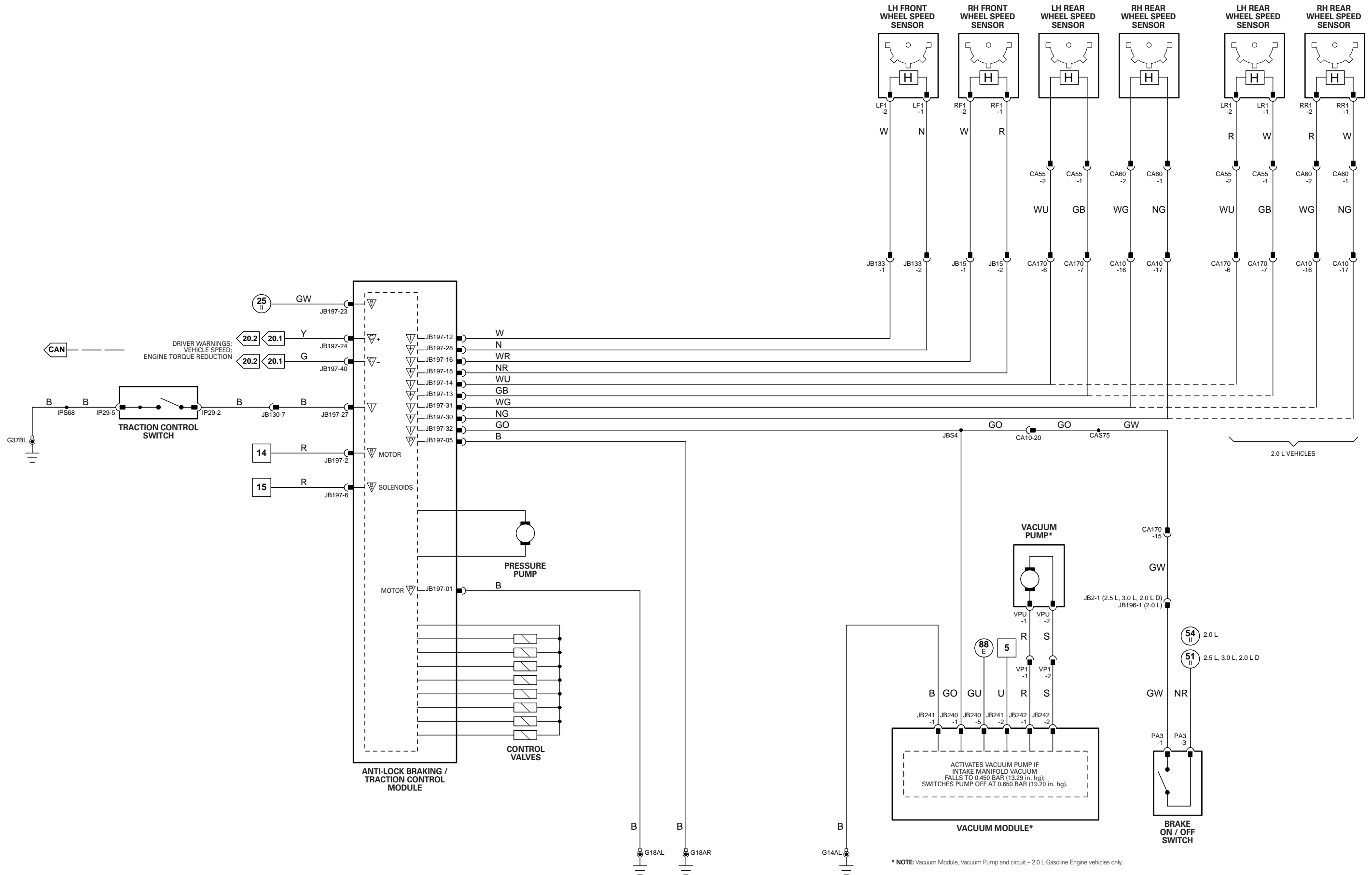

1 → 6	Fig. 01.1	34 → 79	Fig. 01.3	11 → 31	Fig. 01.5	67 → 76	Fig. 01.7	98 → 107	Fig. 01.9
7 → 33	Fig. 01.2	1 → 10	Fig. 01.4	32 → 66	Fig. 01.6	77 → 97	Fig. 01.8		

▽	Input	B	Battery Voltage	▽	Sensor/Signal Supply V	△	CAN	S	D2B Network
○	Output	P	Power Ground	▽	Sensor/Signal Ground	C	SCP	D	Serial and Encoded Data

VARIANT: ABS / TC Vehicles
 VIN RANGE: All
 DATE OF ISSUE: June 2003 (PROVISIONAL)

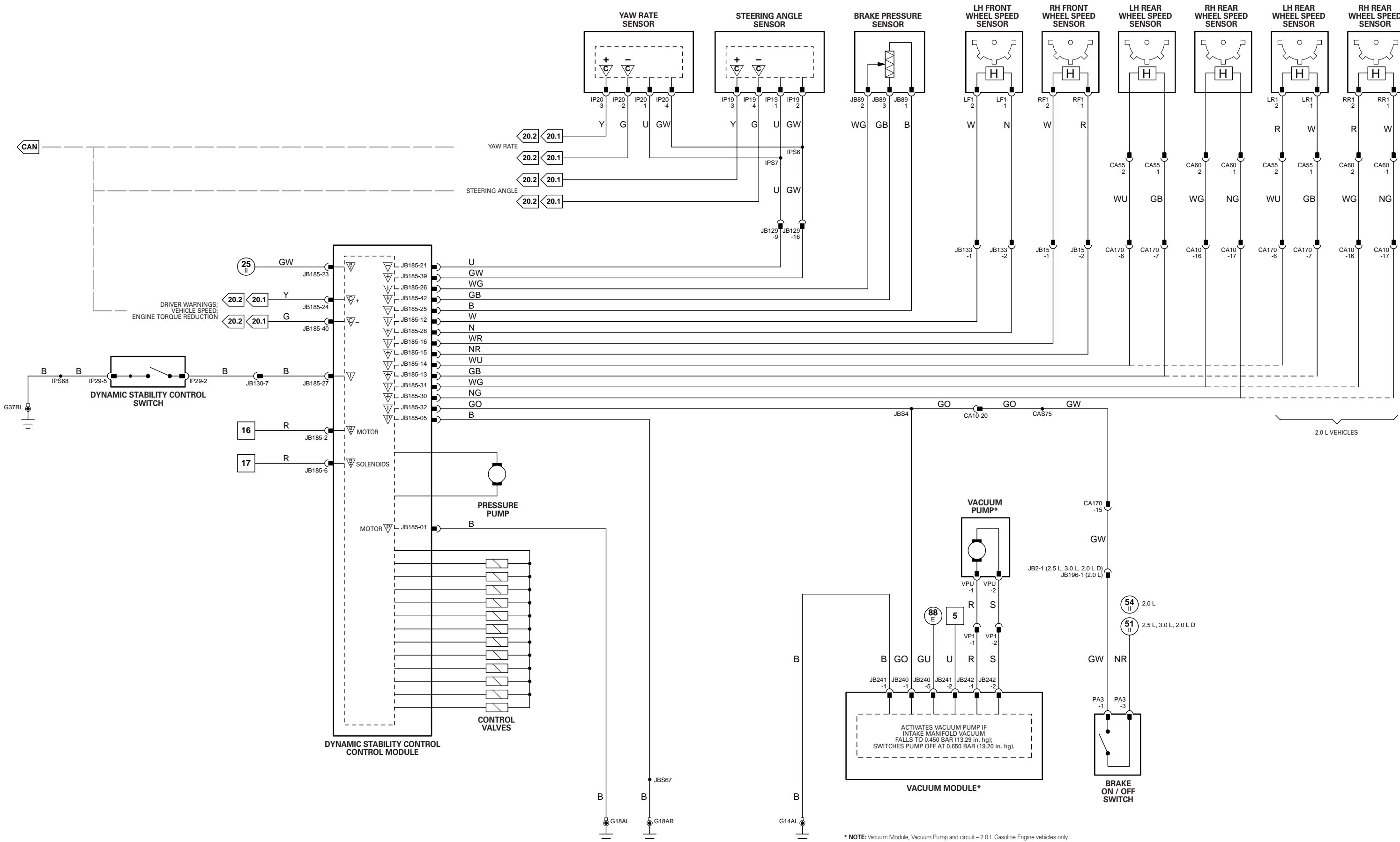



NOTE: The CCM incorporates the control panel for the Climate Control System.

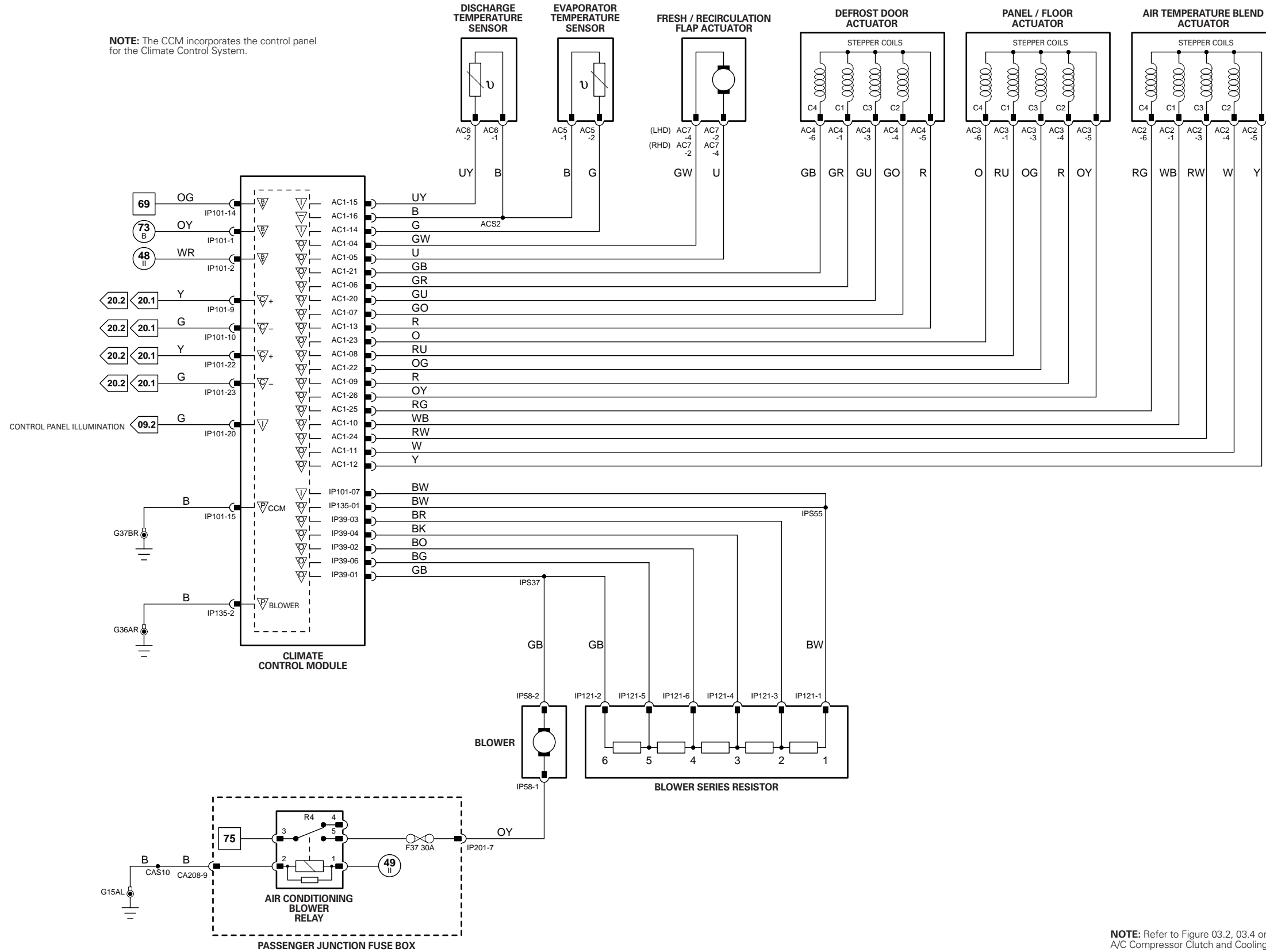

NOTE: Refer to Figure 03.2, 03.4 or 03.6 for A/C Compressor Clutch and Cooling Fan circuits.



NOTE: Vehicles without Navigation "Touch Screen" - The CCM incorporates the control panel for the Climate Control System.

Vehicles with Navigation "Touch Screen" - The CCM is remotely mounted on the Climate Control Unit. Driver control inputs are received via Network Communication.

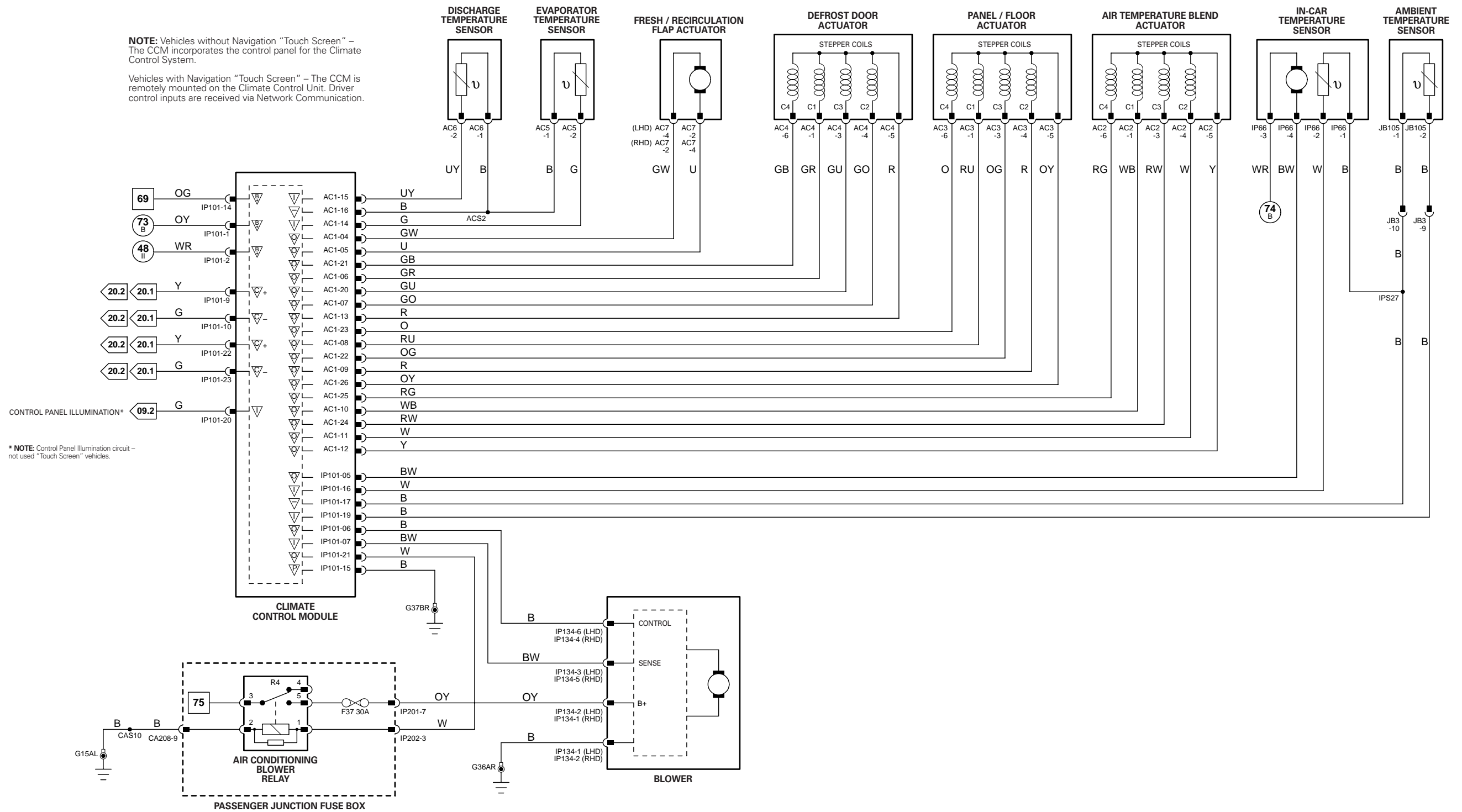

* NOTE: Control Panel Illumination circuit - not used "Touch Screen" vehicles.

NOTE: Refer to Figure 03.2, 03.4 or 03.6 for A/C Compressor Clutch and Cooling Fan circuits.

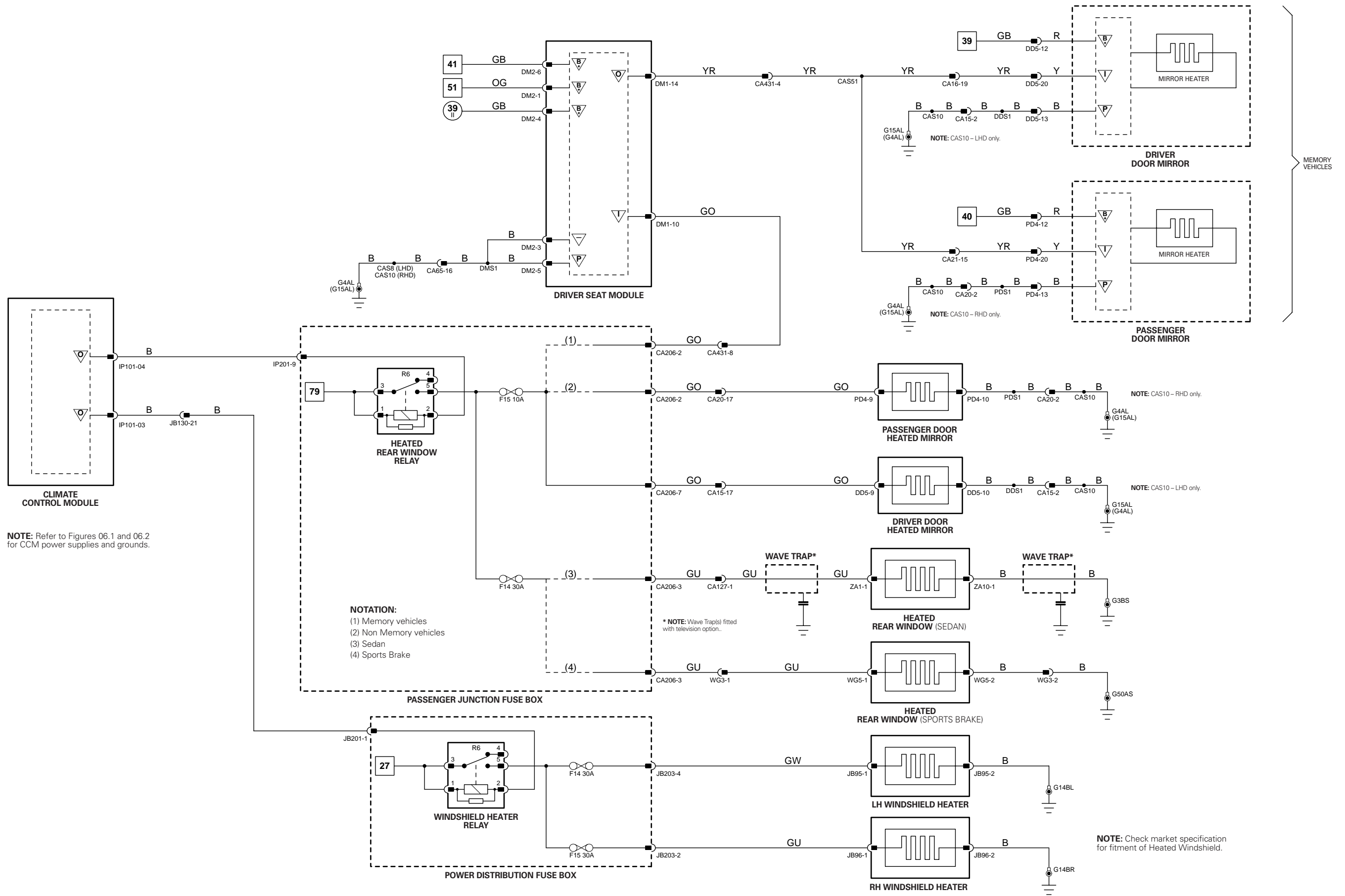

1 → 6	Fig. 01.1	34 → 79	Fig. 01.3	11 → 31	Fig. 01.5	67 → 76	Fig. 01.7	98 → 107	Fig. 01.9	▽	Input	⊖	Battery Voltage	▽	Sensor/Signal Supply V	▽	CAN	⊖	D2B Network
7 → 33	Fig. 01.2	1 → 10	Fig. 01.4	32 → 66	Fig. 01.6	77 → 97	Fig. 01.8			▽	Output	⊖	Power Ground	▽	Sensor/Signal Ground	▽	SCP	▽	Serial and Encoded Data

VARIANT: All Vehicles
VIN RANGE: All
DATE OF ISSUE: June 2003 (PROVISIONAL)

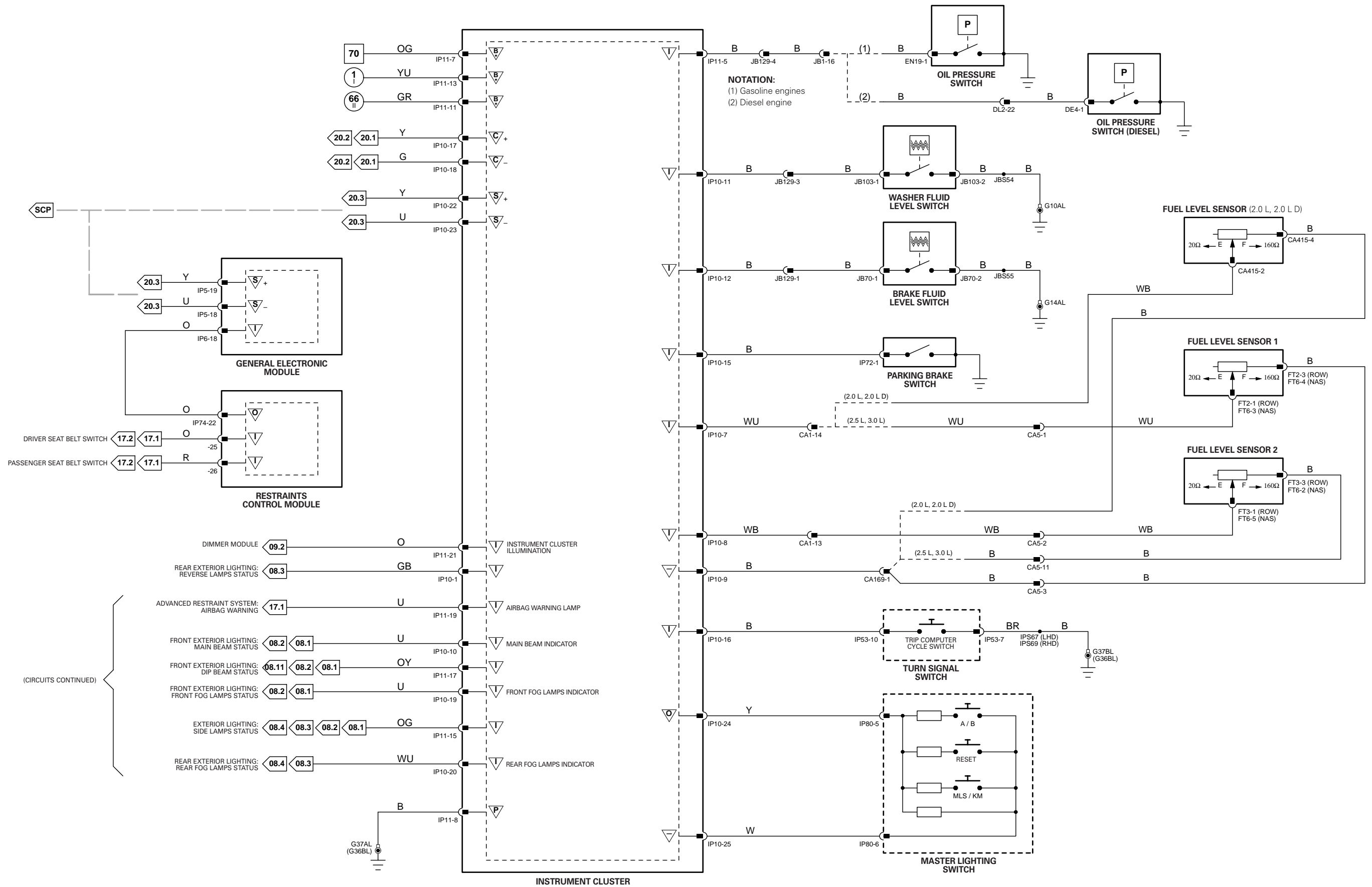

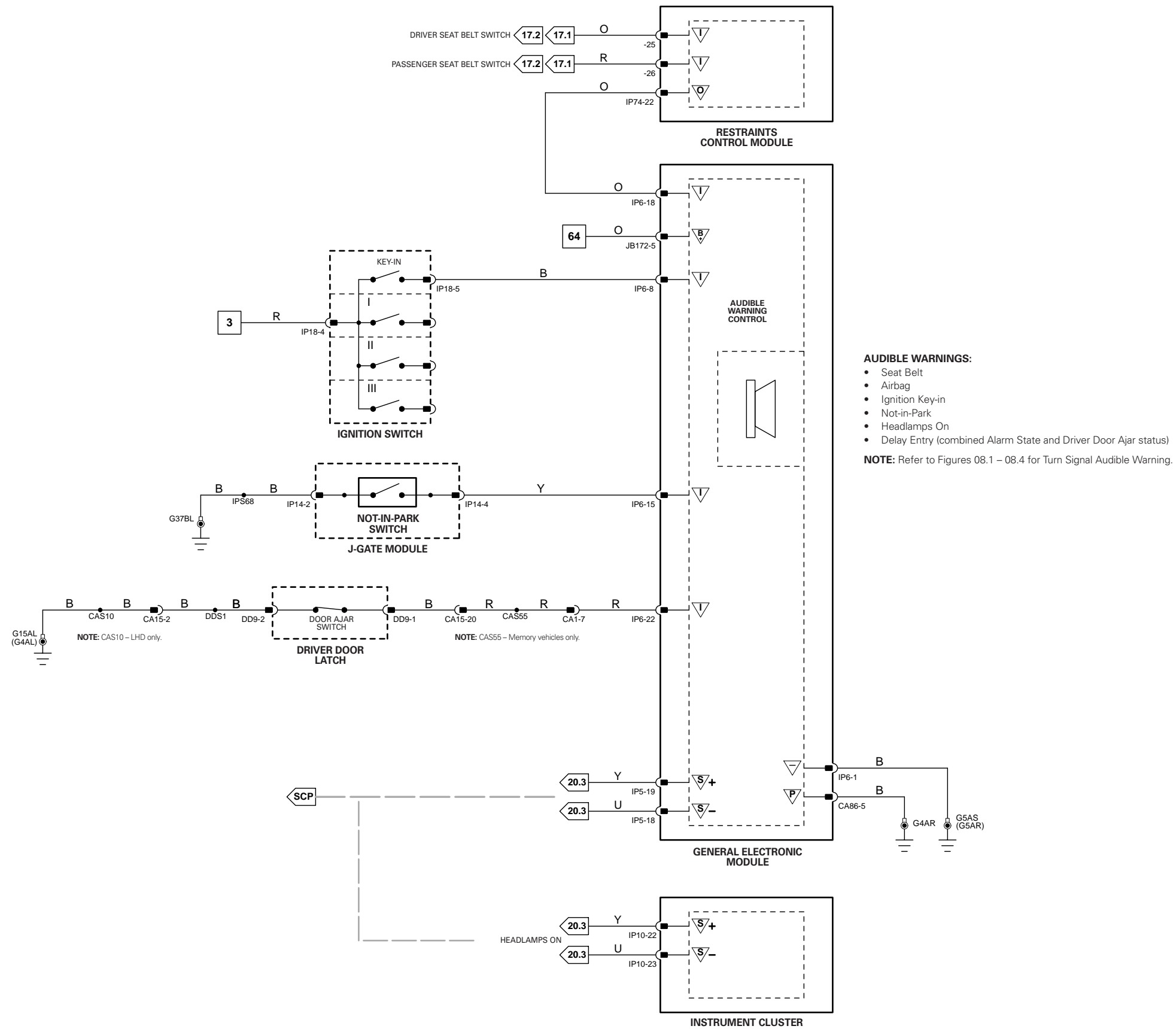

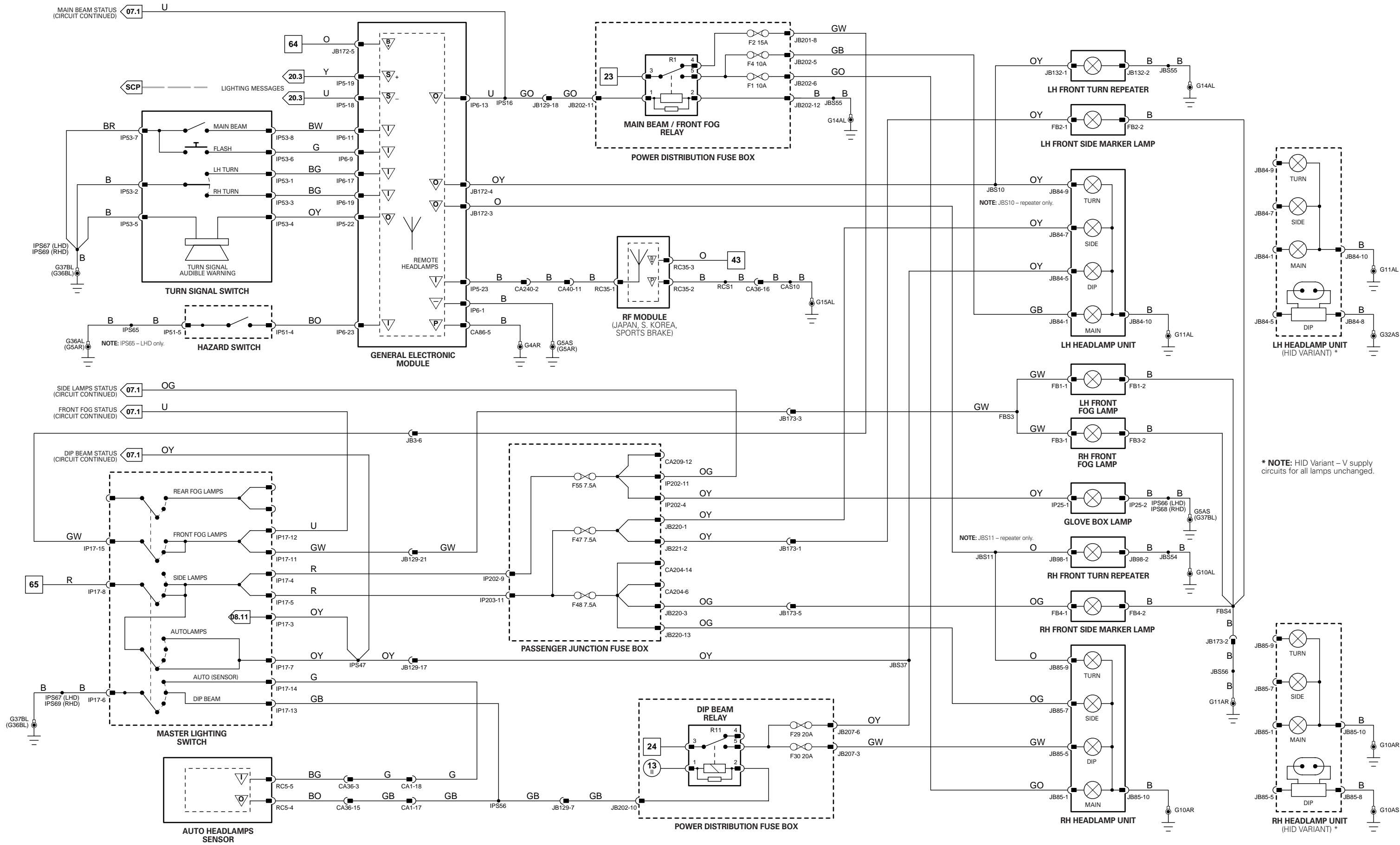

* NOTE: HID Variant – V supply circuits for all lamps unchanged.

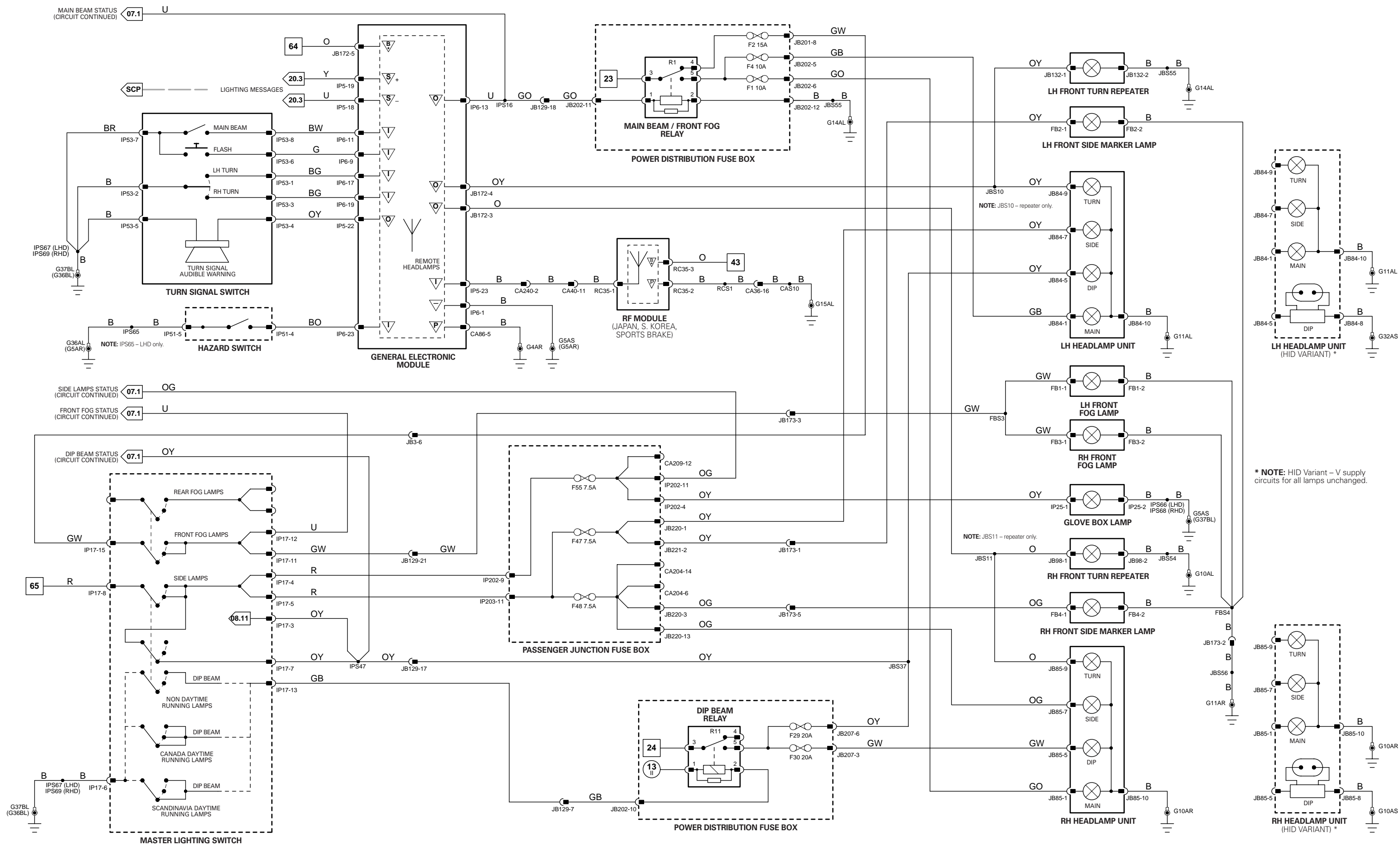

* NOTE: HID Variant – V supply circuits for all lamps unchanged.

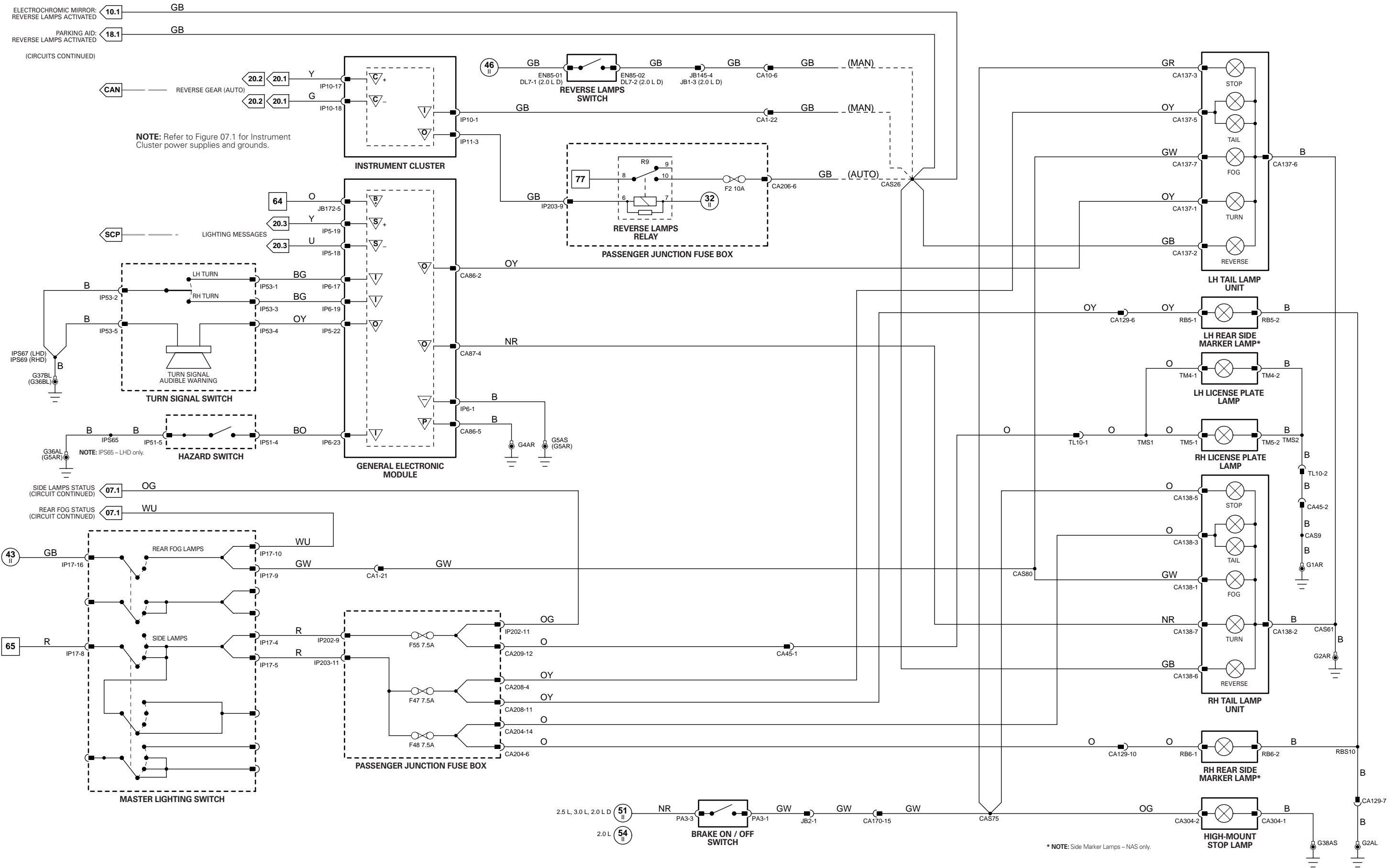

1 → 6 Fig. 01.1	34 → 79 Fig. 01.3	11 → 31 Fig. 01.5	67 → 76 Fig. 01.7	98 → 107 Fig. 01.9	Input	Battery Voltage	Sensor/Signal Supply V	CAN	D2B Network
7 → 33 Fig. 01.2	1 → 10 Fig. 01.4	32 → 66 Fig. 01.6	77 → 97 Fig. 01.8		Output	Power Ground	Sensor/Signal Ground	SCP	Serial and Encoded Data

VARIANT: Sedan Vehicles
 VIN RANGE: All
 DATE OF ISSUE: June 2003 (PROVISIONAL)

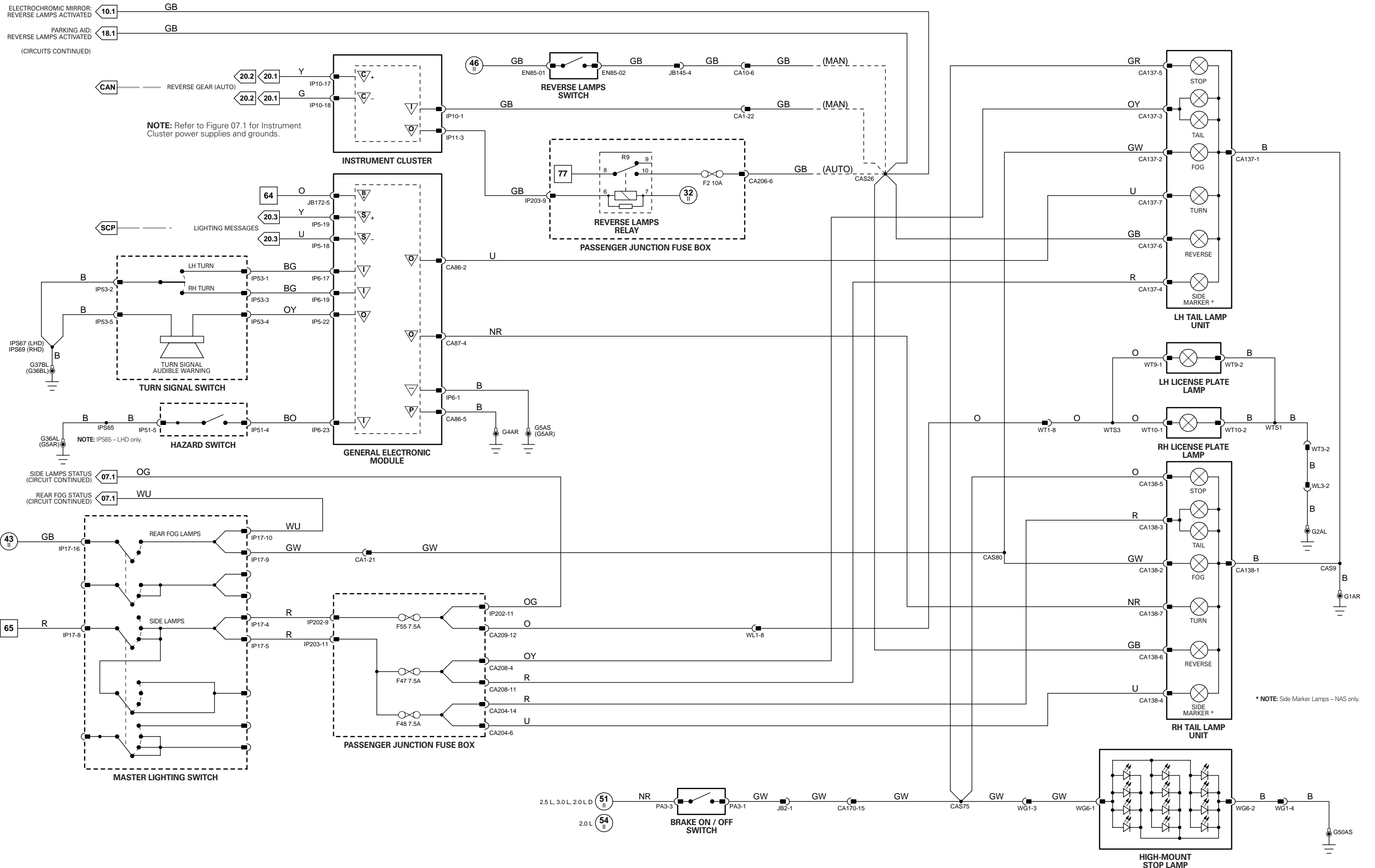

* NOTE: Side Marker Lamps – NAS only.

1 → 6 Fig. 01.1	34 → 79 Fig. 01.3	11 → 31 Fig. 01.5	67 → 76 Fig. 01.7	98 → 107 Fig. 01.9	▽ Input	B Battery Voltage	▽ Sensor/Signal Supply V	△ CAN	S D2B Network
7 → 33 Fig. 01.2	1 → 10 Fig. 01.4	32 → 66 Fig. 01.6	77 → 97 Fig. 01.8		▽ Output	P Power Ground	▽ Sensor/Signal Ground	▽ SCP	D Serial and Encoded Data

VARIANT: Sports Brake Vehicles
VIN RANGE: All
DATE OF ISSUE: June 2003 (PROVISIONAL)

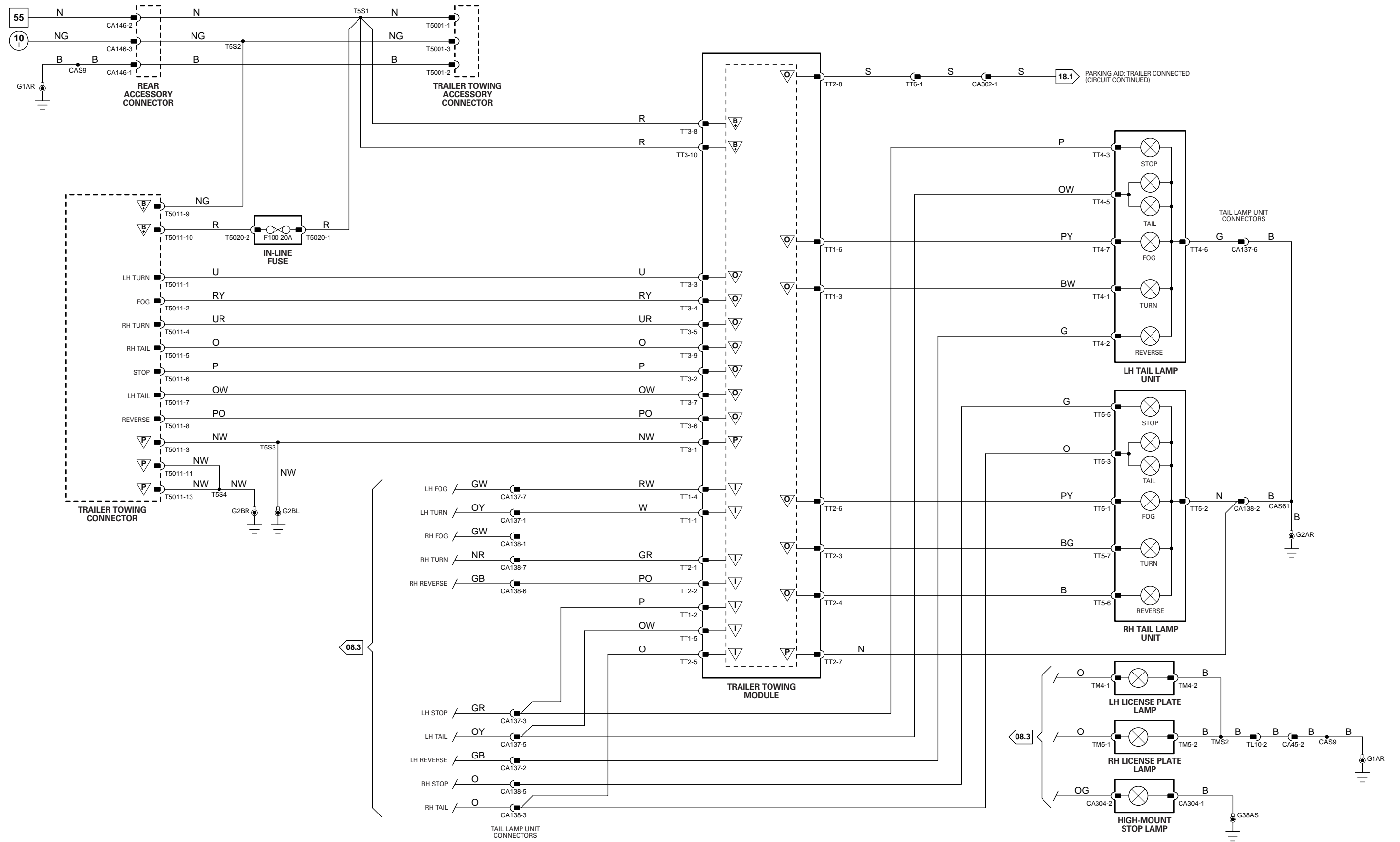

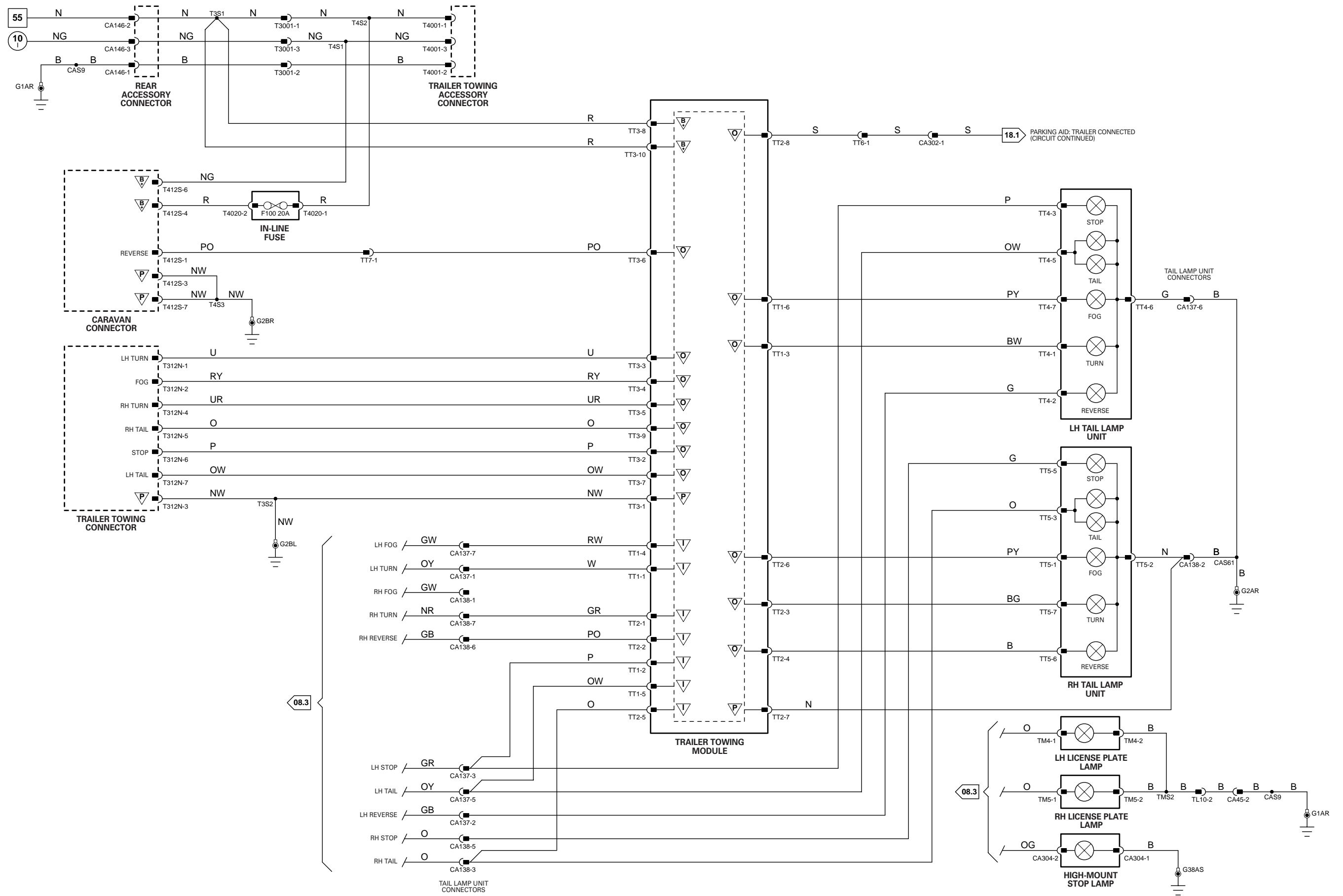

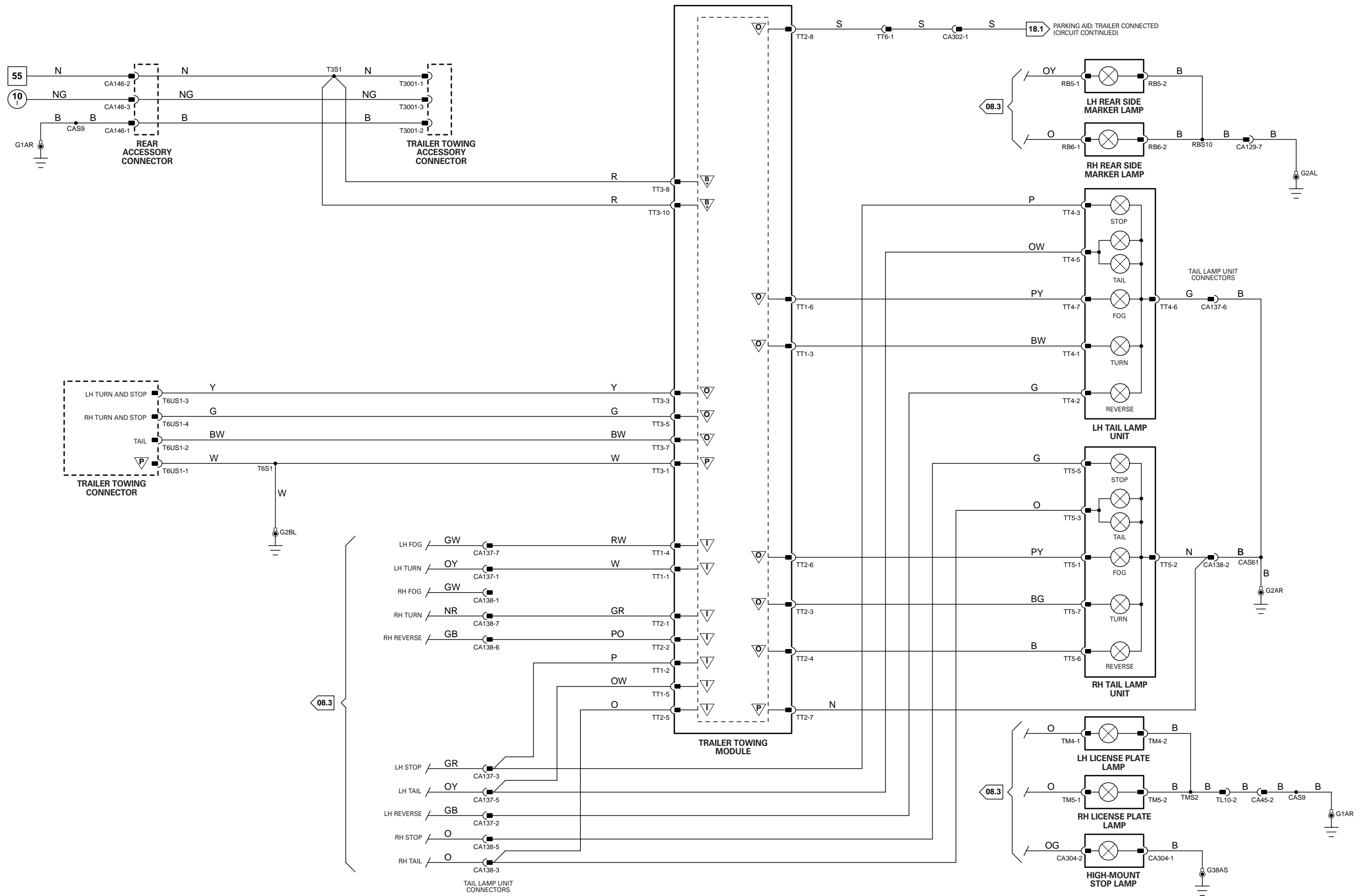

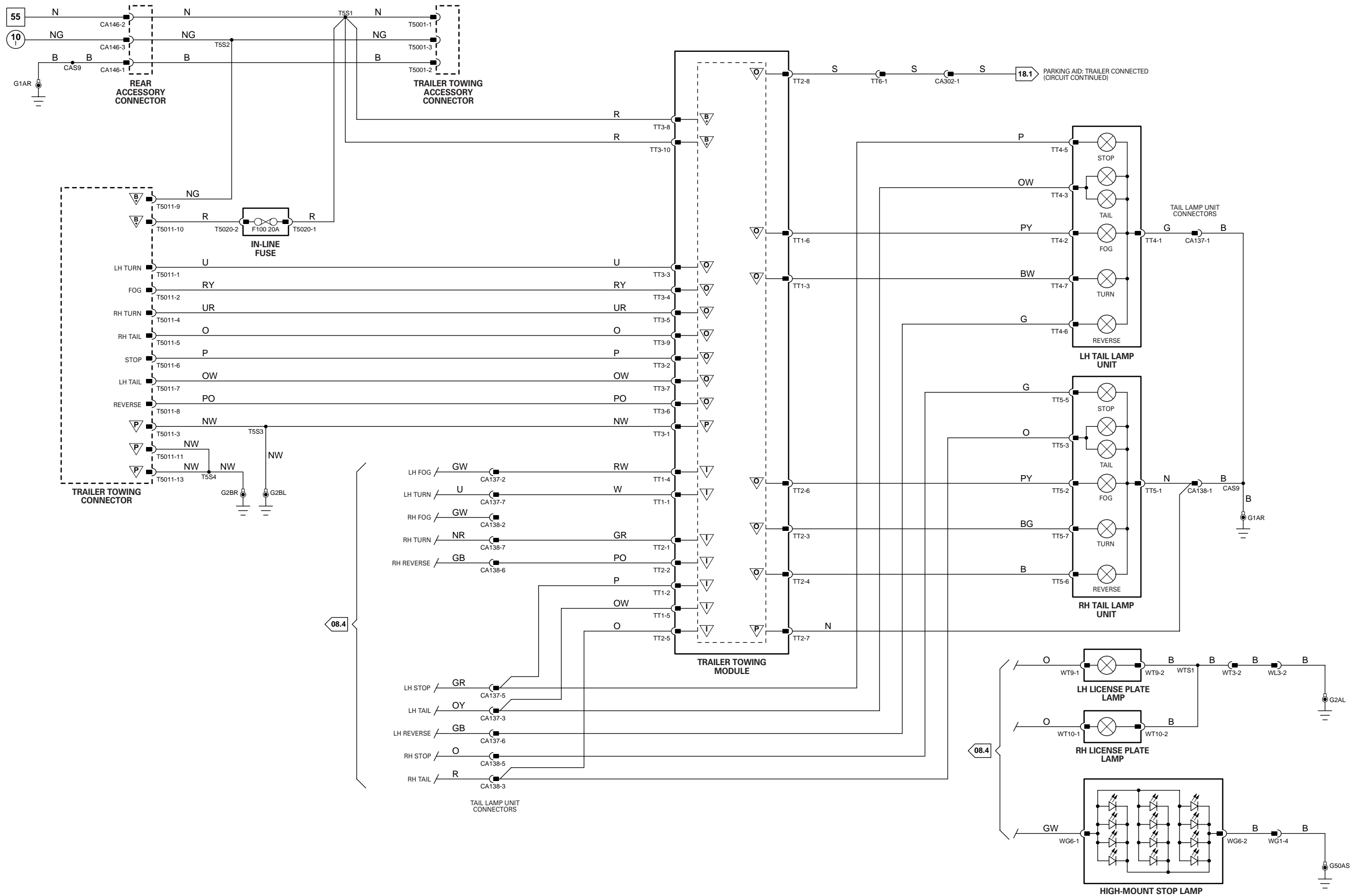

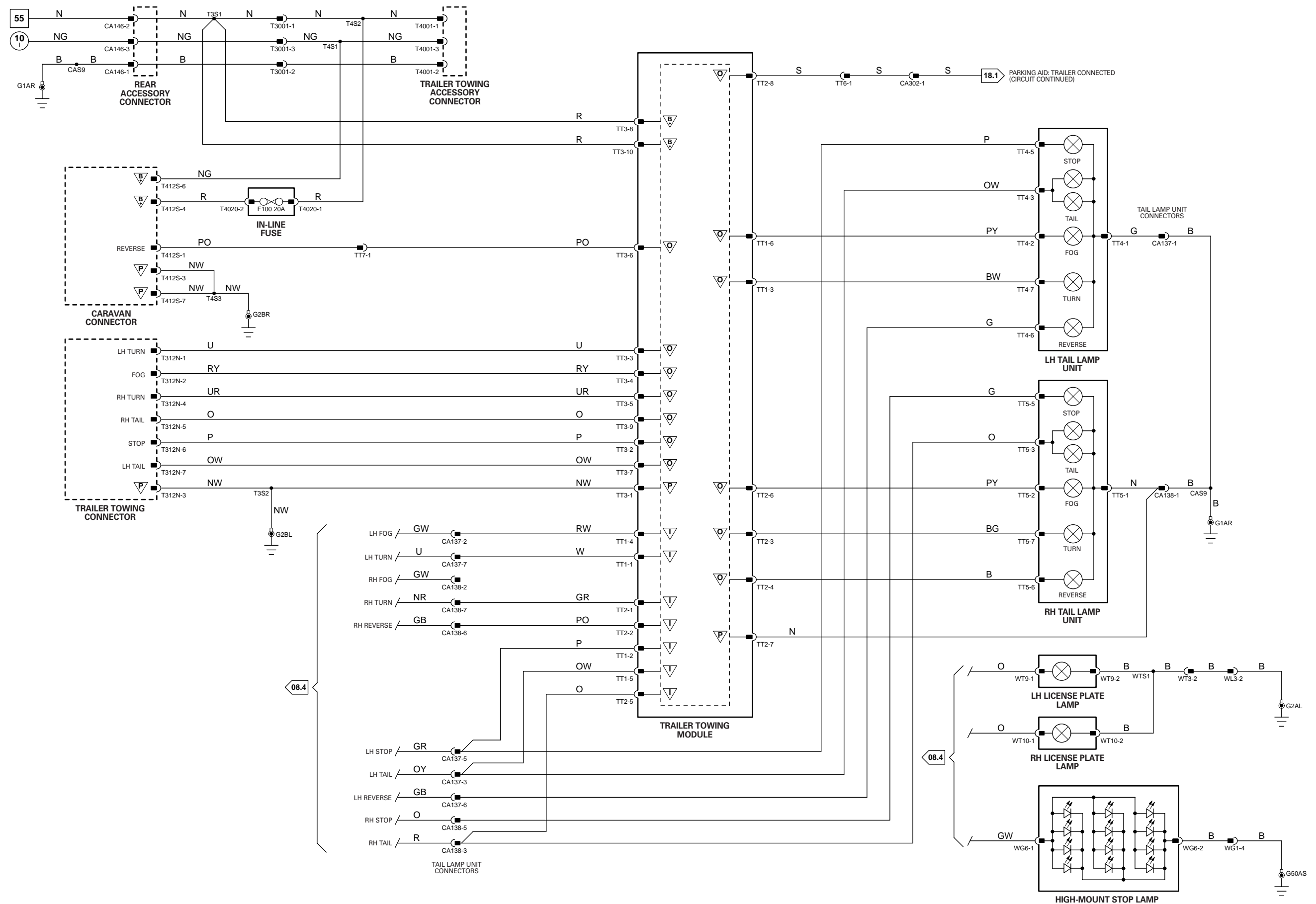

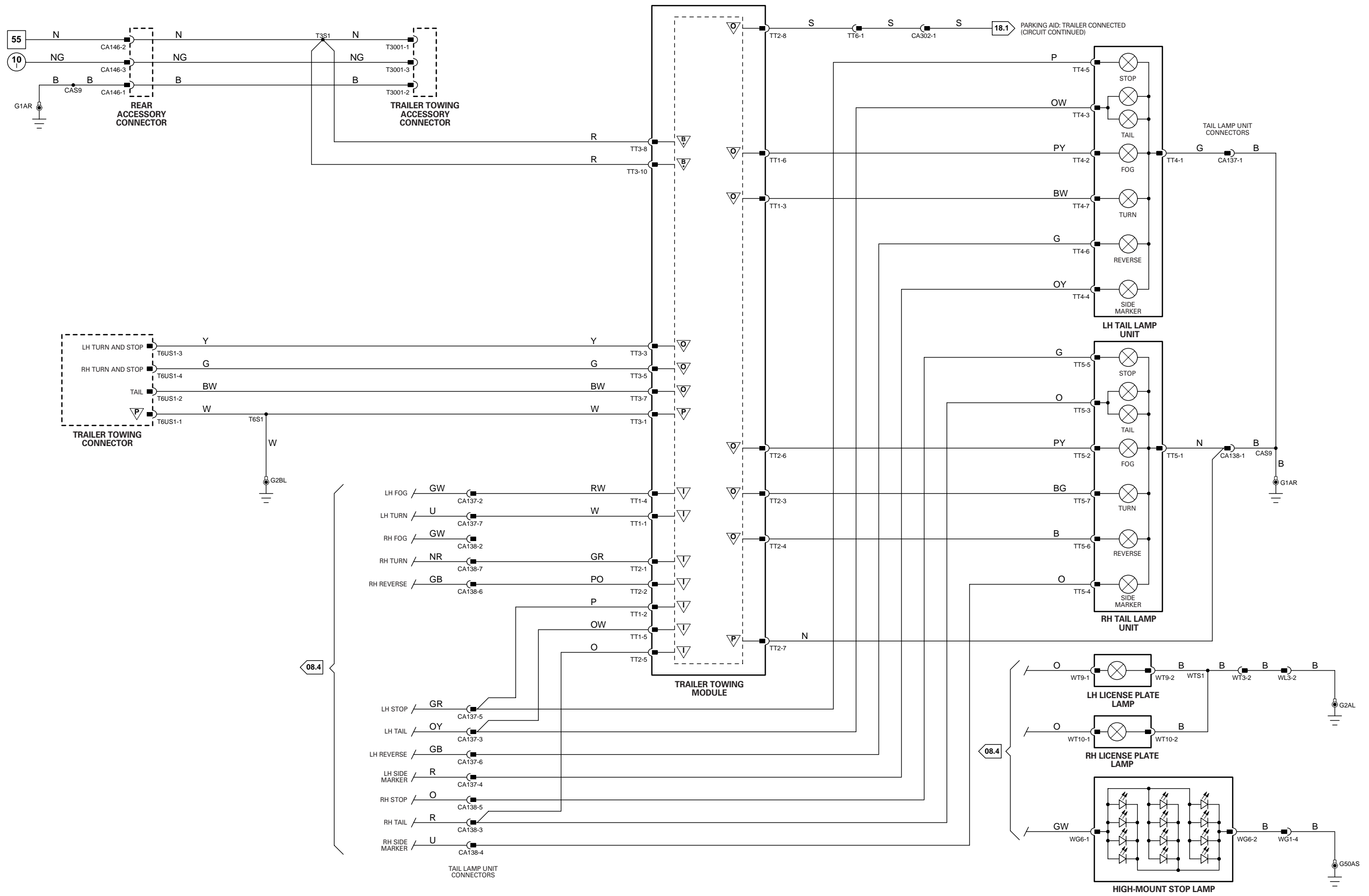

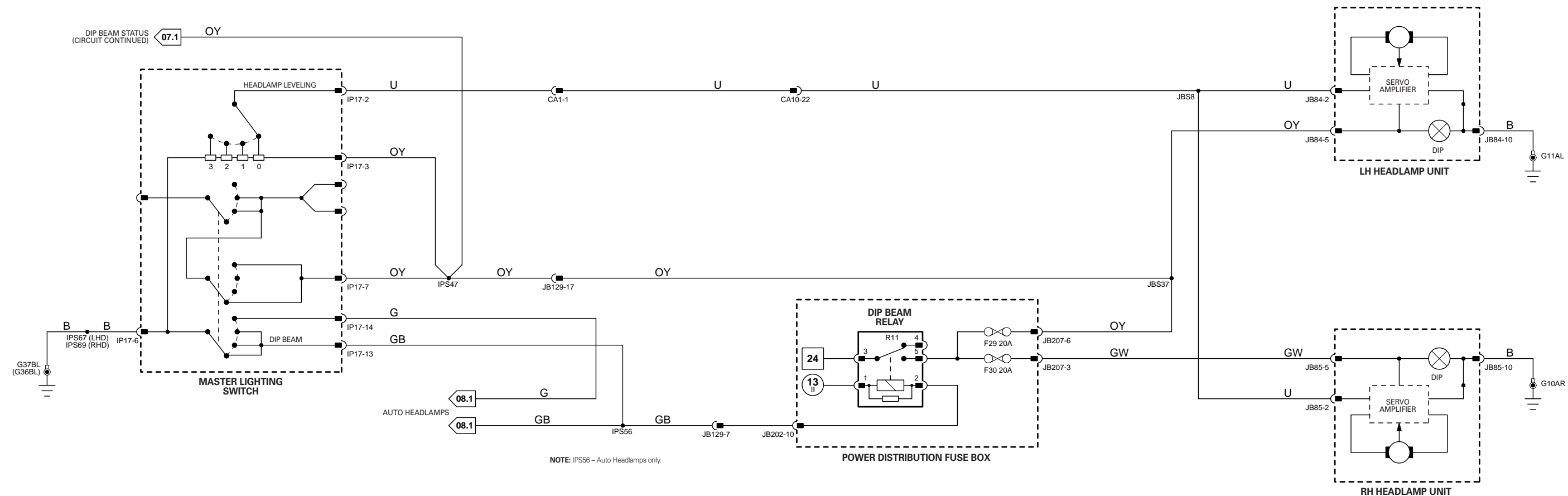

DRIVER-CONTROLLED HEADLAMP LEVELING

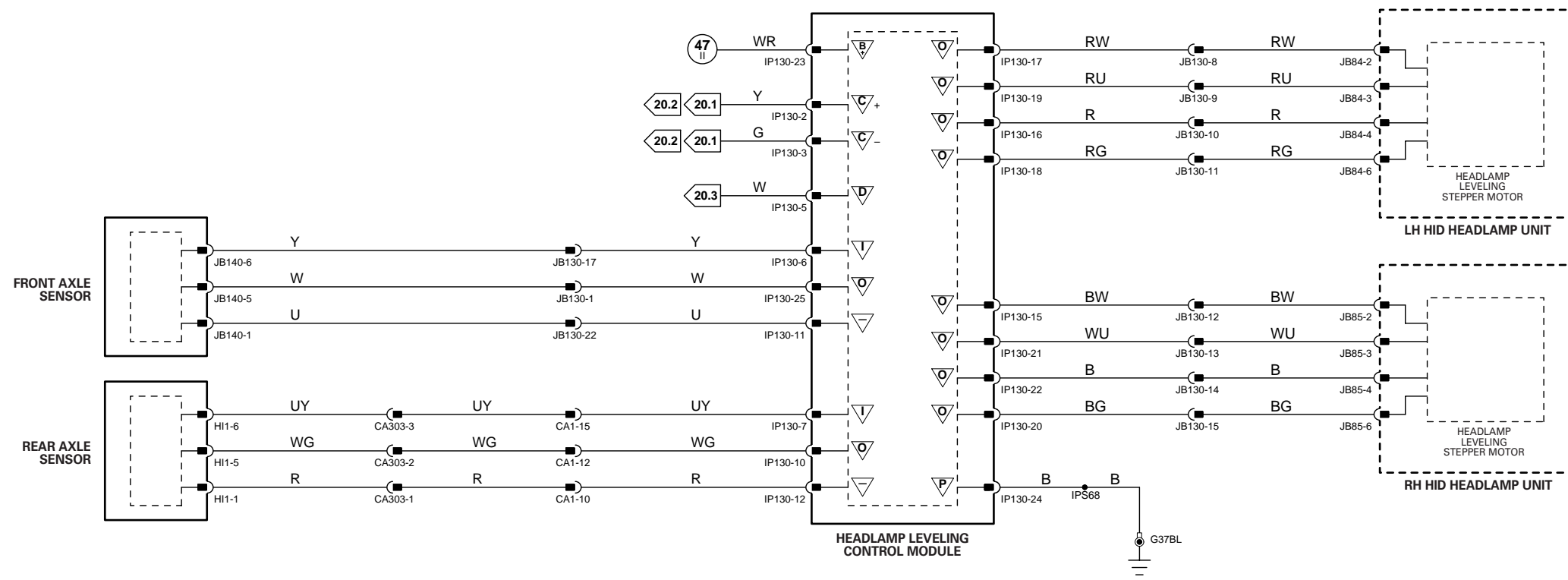

AUTOMATIC HEADLAMP LEVELING

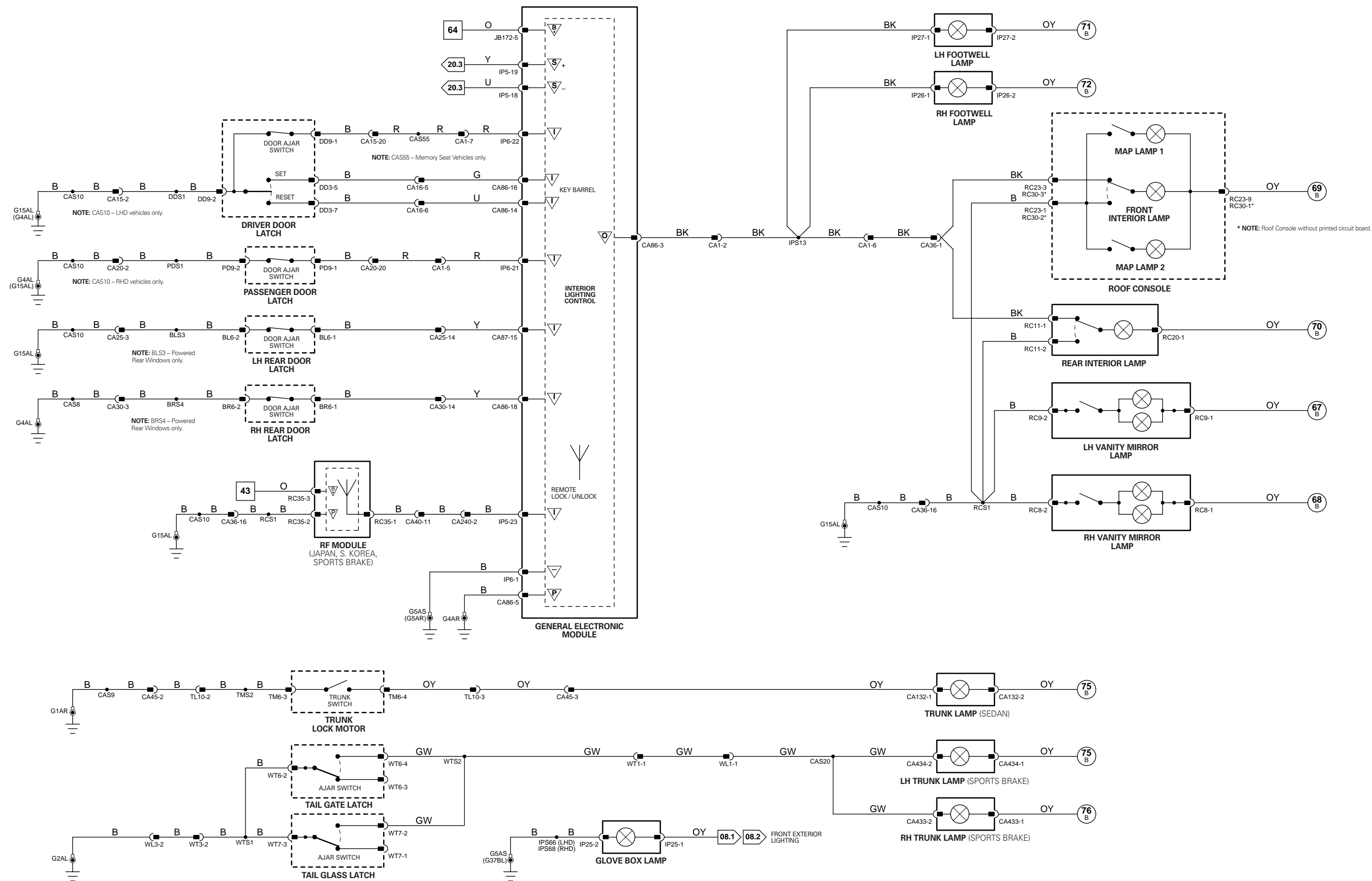

1 → 6 Fig. 01.1	34 → 79 Fig. 01.3	11 → 31 Fig. 01.5	67 → 76 Fig. 01.7	98 → 107 Fig. 01.9	▽ Input	⊖ Battery Voltage	▽ Sensor/Signal Supply V	△ CAN	⊘ D2B Network
7 → 33 Fig. 01.2	1 → 10 Fig. 01.4	32 → 66 Fig. 01.6	77 → 97 Fig. 01.8		○ Output	⊖ Power Ground	▽ Sensor/Signal Ground	▽ SCP	▽ Serial and Encoded Data

VARIANT: All Vehicles
VIN RANGE: All
DATE OF ISSUE: June 2003 (PROVISIONAL)

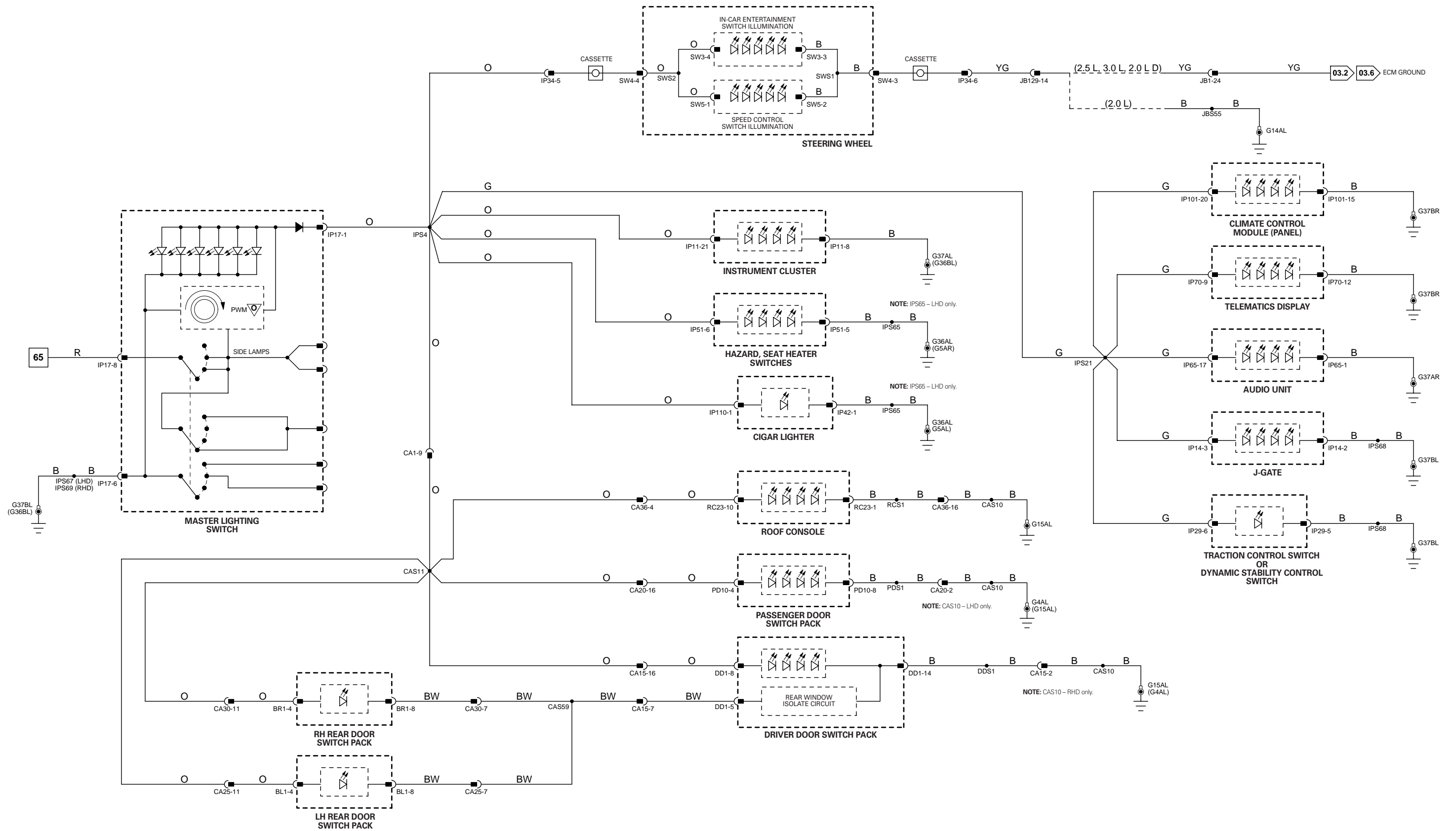

1 → 6	Fig. 01.1	34 → 79	Fig. 01.3	11 → 31	Fig. 01.5	67 → 76	Fig. 01.7	98 → 107	Fig. 01.9	▽ Input	B Battery Voltage	▽ Sensor/Signal Supply V	△ CAN	S D2B Network
7 → 33	Fig. 01.2	1 → 10	Fig. 01.4	32 → 66	Fig. 01.6	77 → 97	Fig. 01.8			○ Output	P Power Ground	▽ Sensor/Signal Ground	C SCP	D Serial and Encoded Data

VARIANT: All Vehicles
VIN RANGE: All
DATE OF ISSUE: June 2003 (PROVISIONAL)

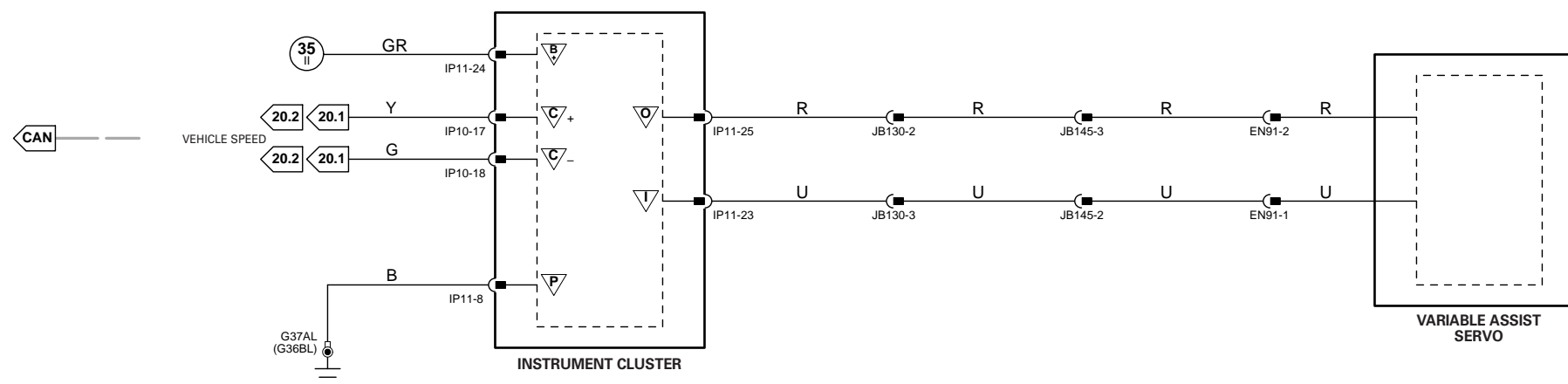

VARIABLE ASSIST STEERING

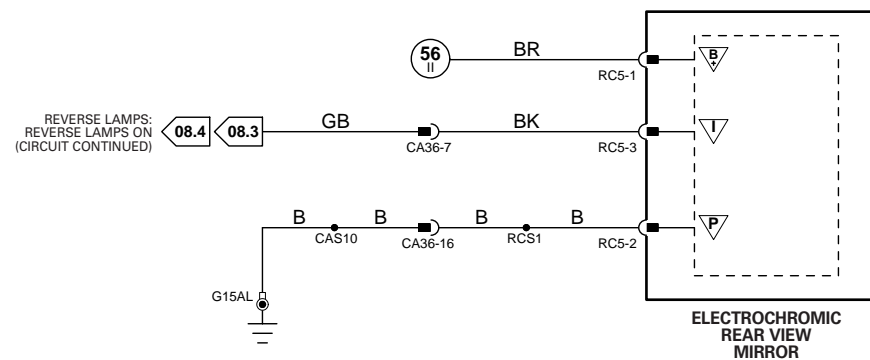

ELECTROCHROMIC REAR VIEW MIRROR

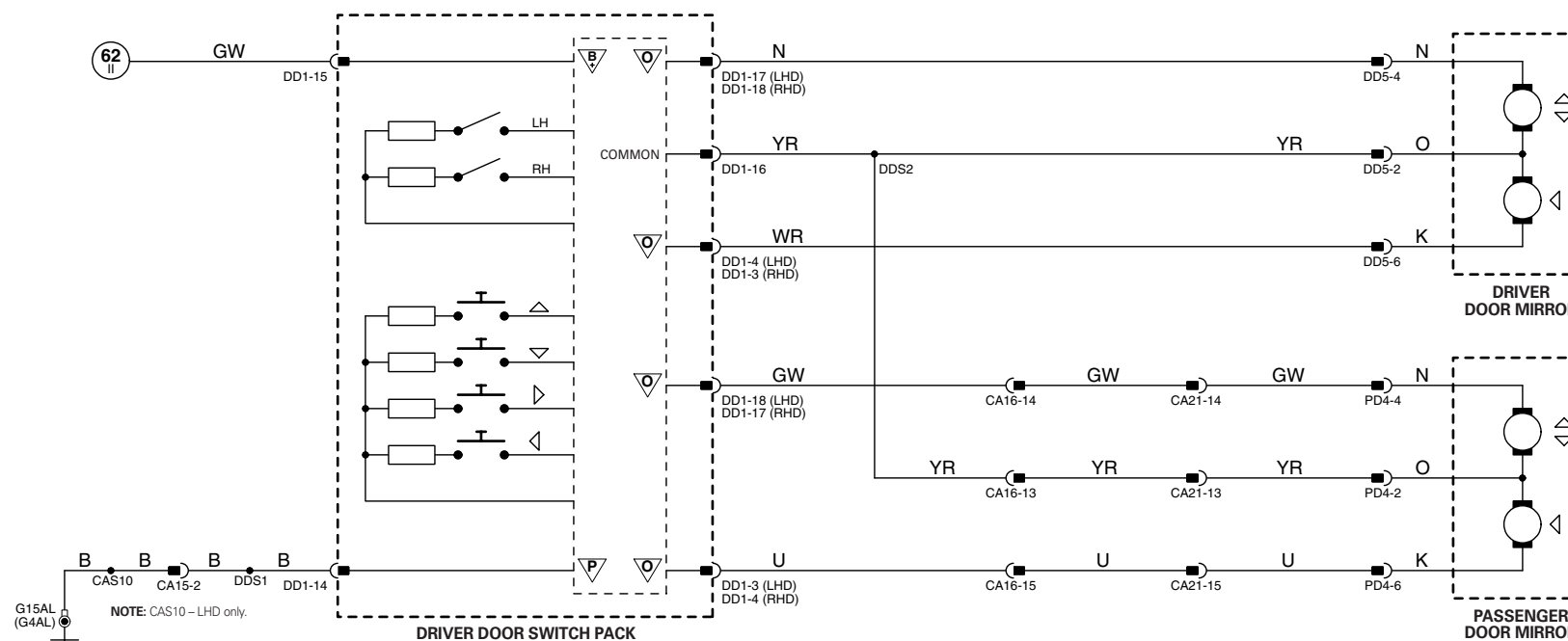

DOOR MIRROR MOVEMENT

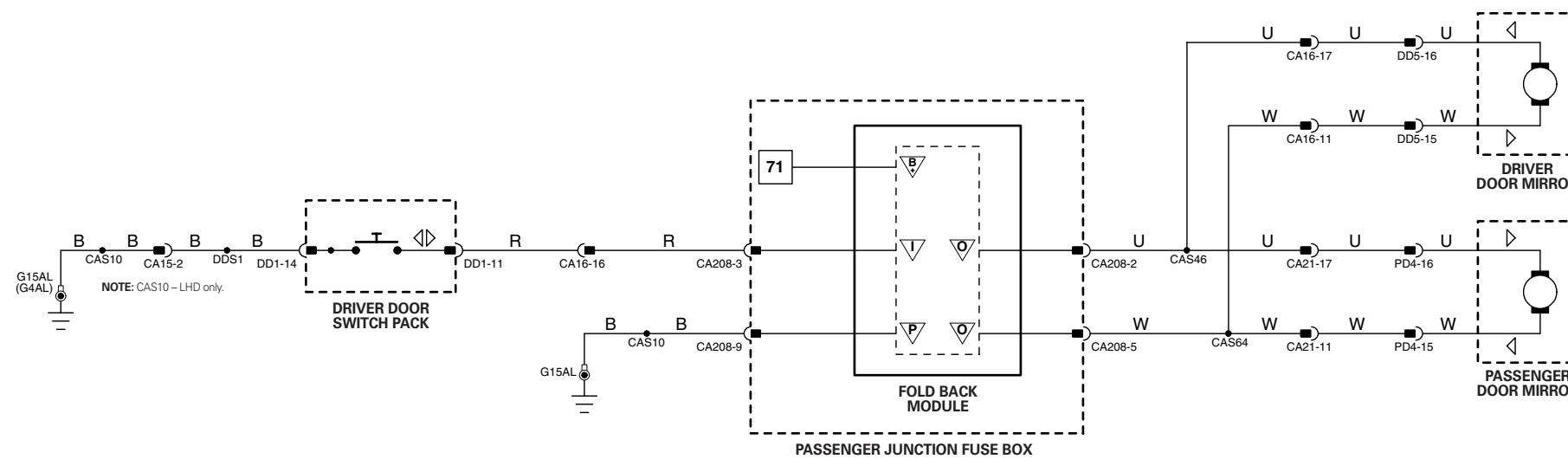

NOTE: Refer to Figure 06.3 for Mirror Heaters.

DOOR MIRRORS: FOLD-BACK

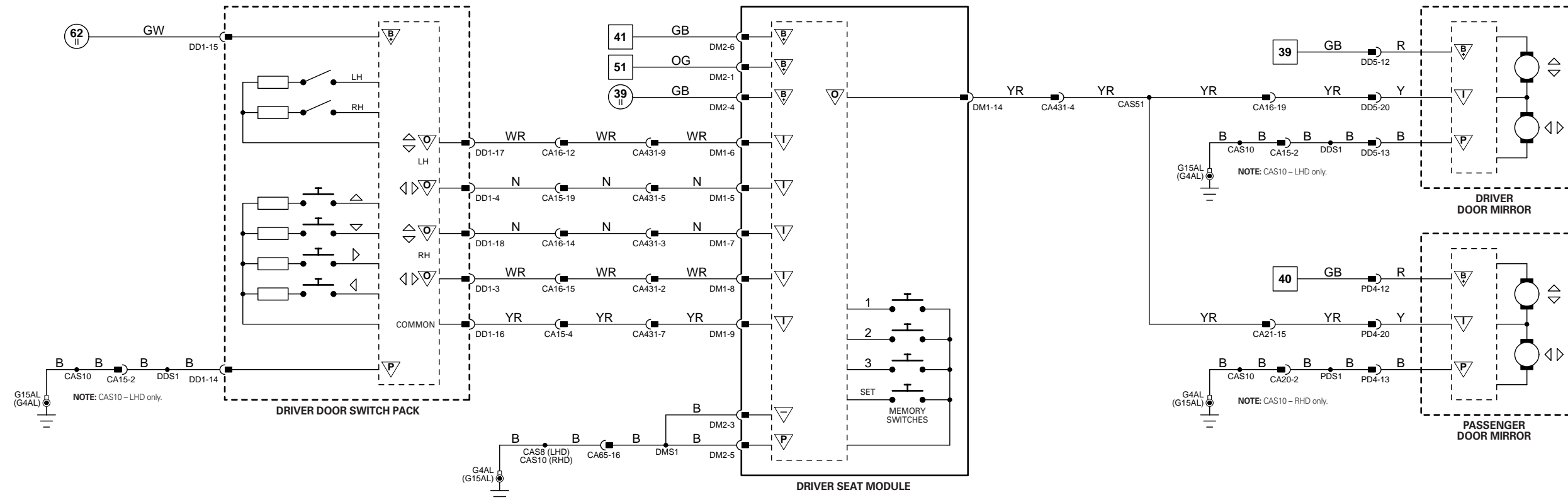

DOOR MIRROR MOVEMENT

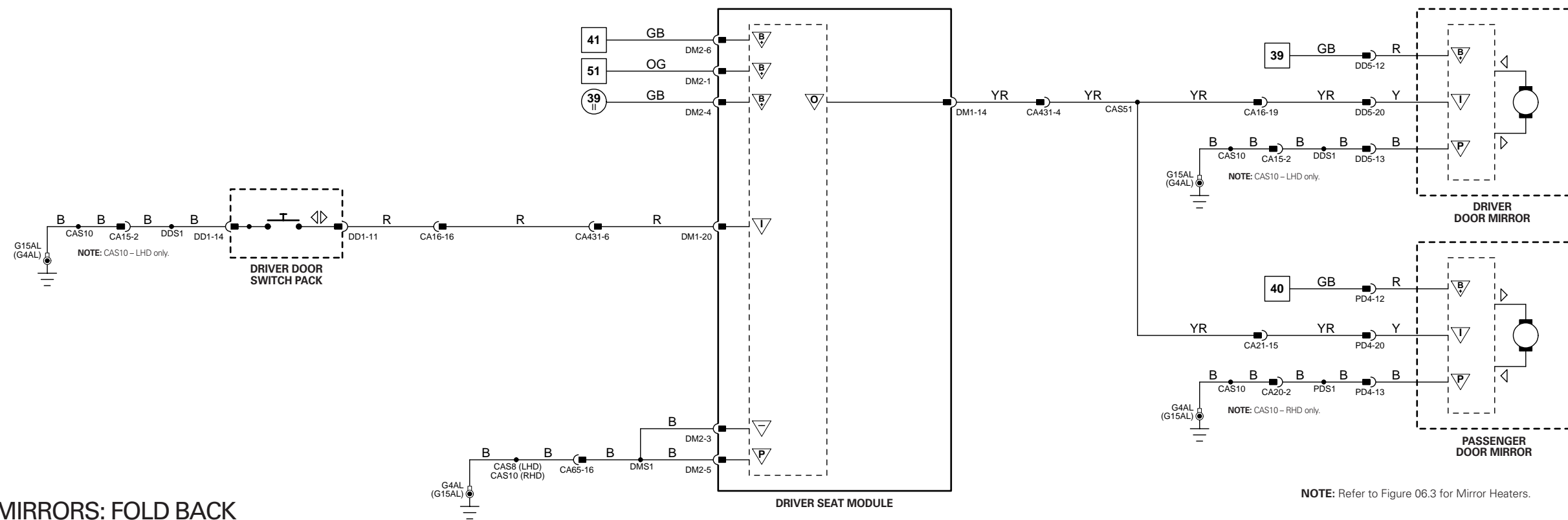

DOOR MIRRORS: FOLD BACK

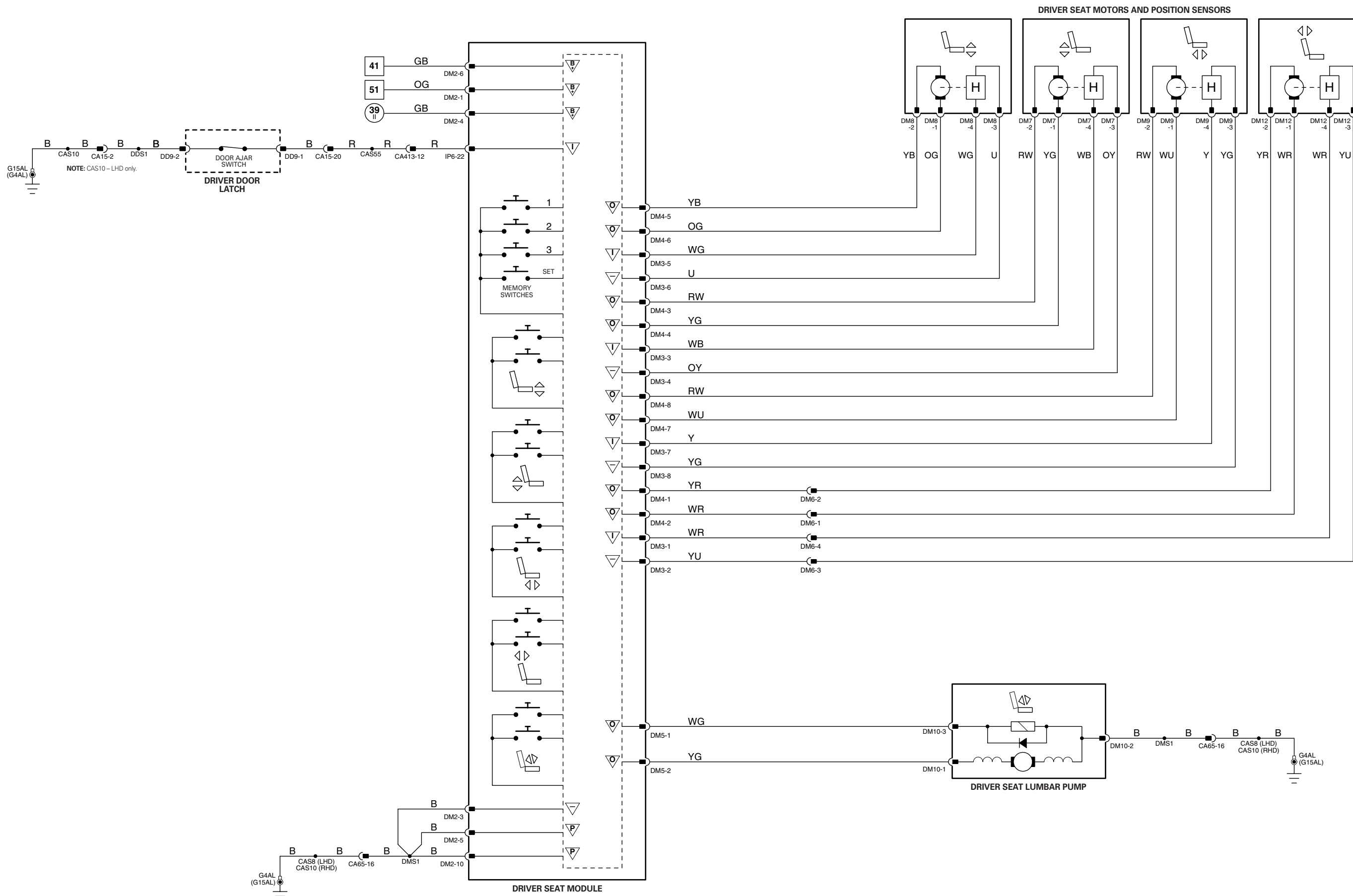

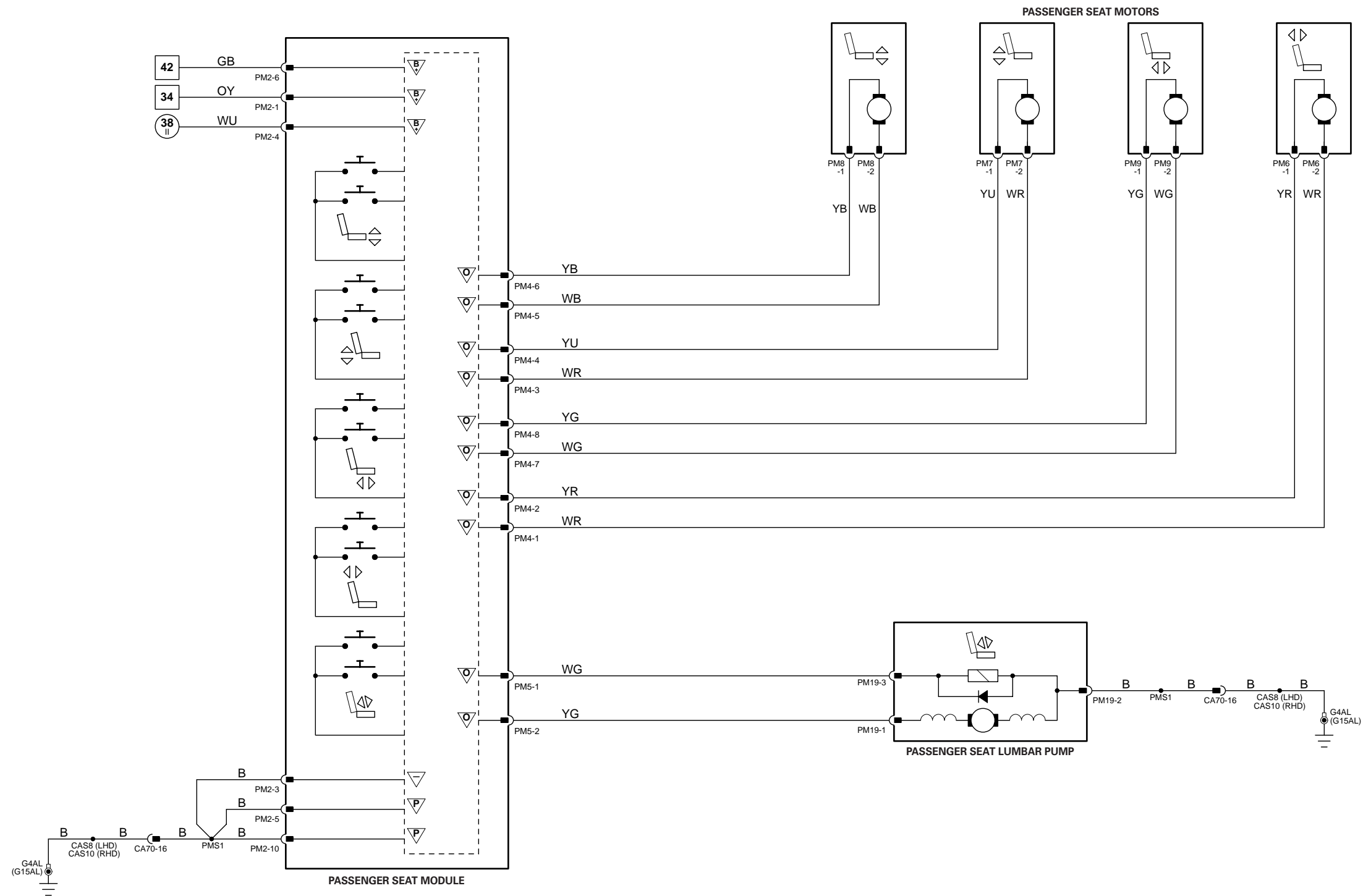

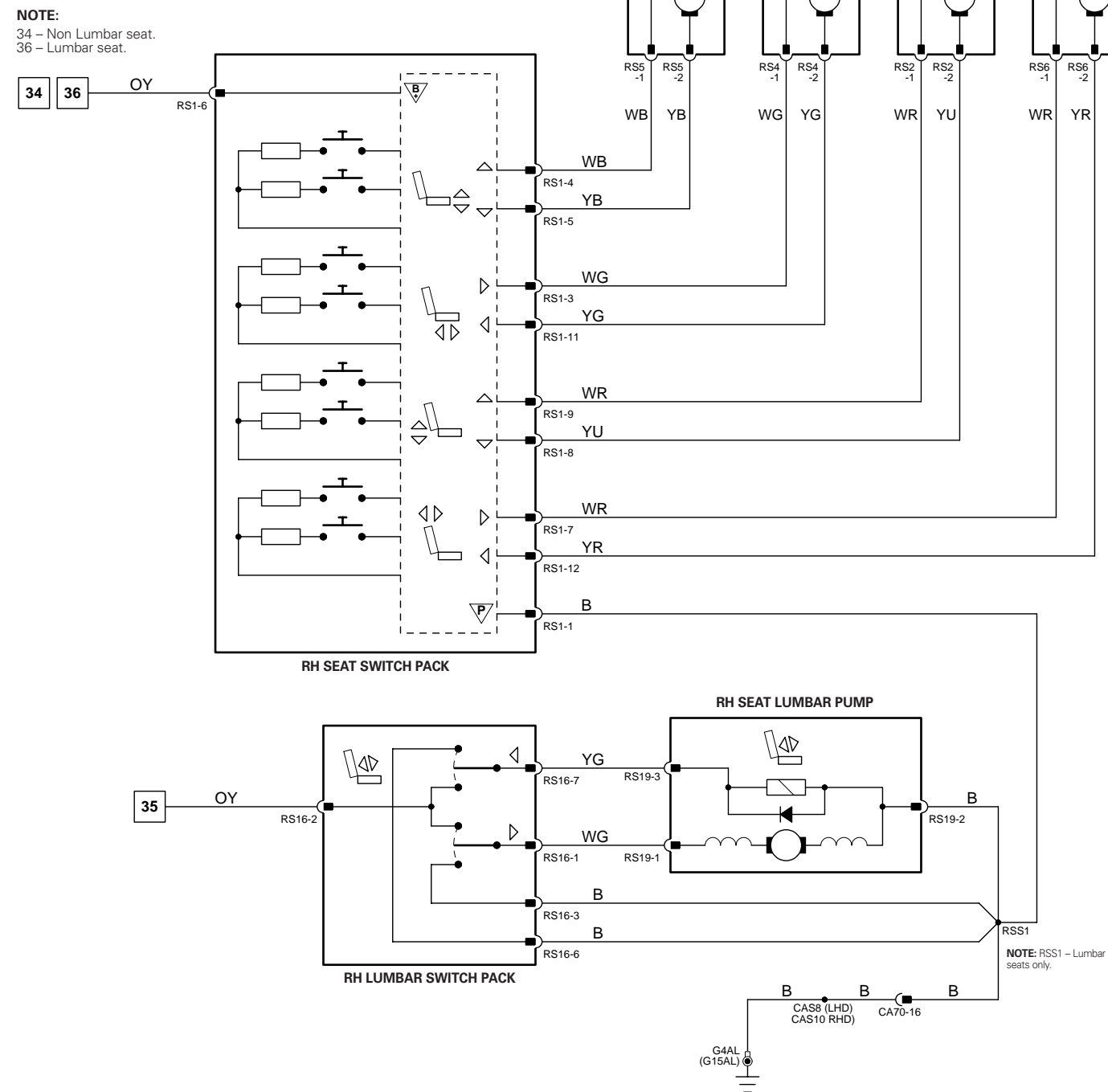
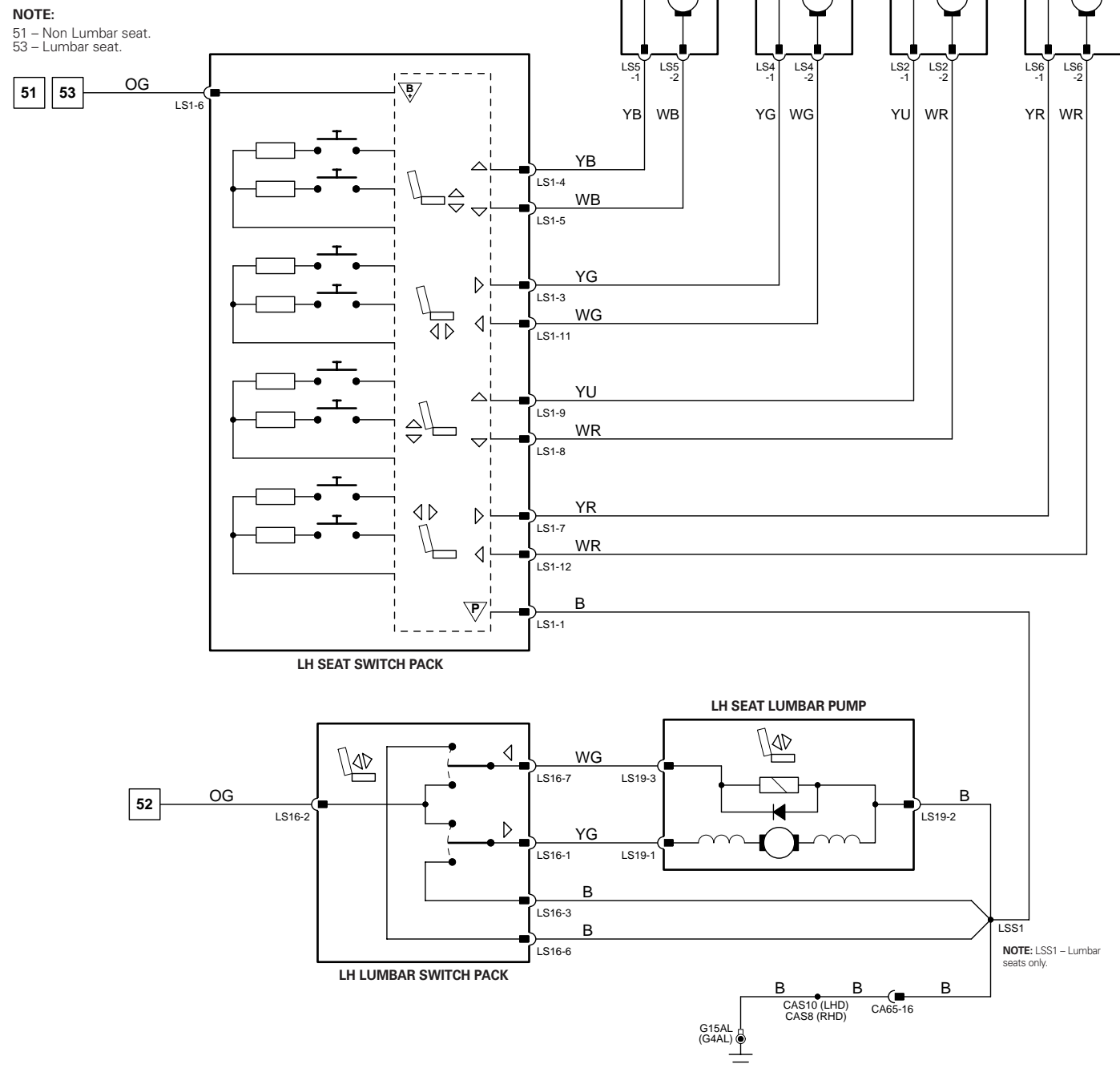

NOTE: Powered Lumbar circuit and components – Powered Lumbar seats only.

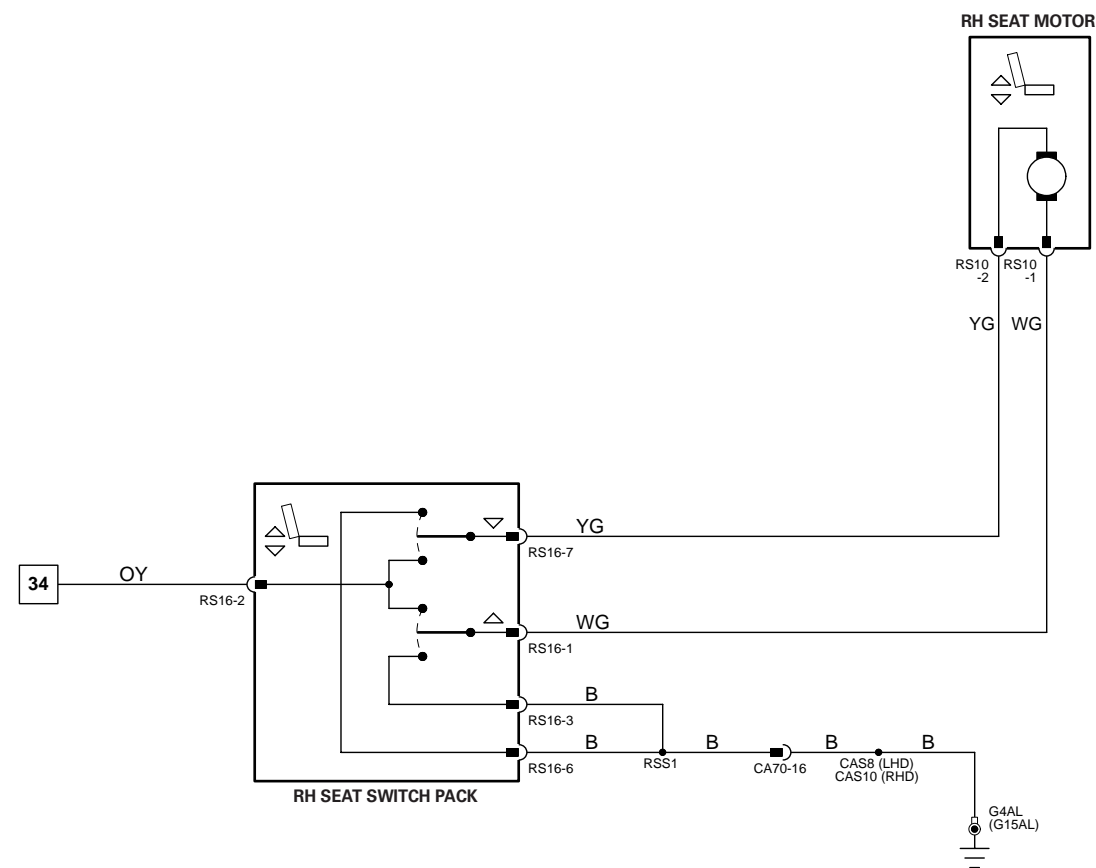
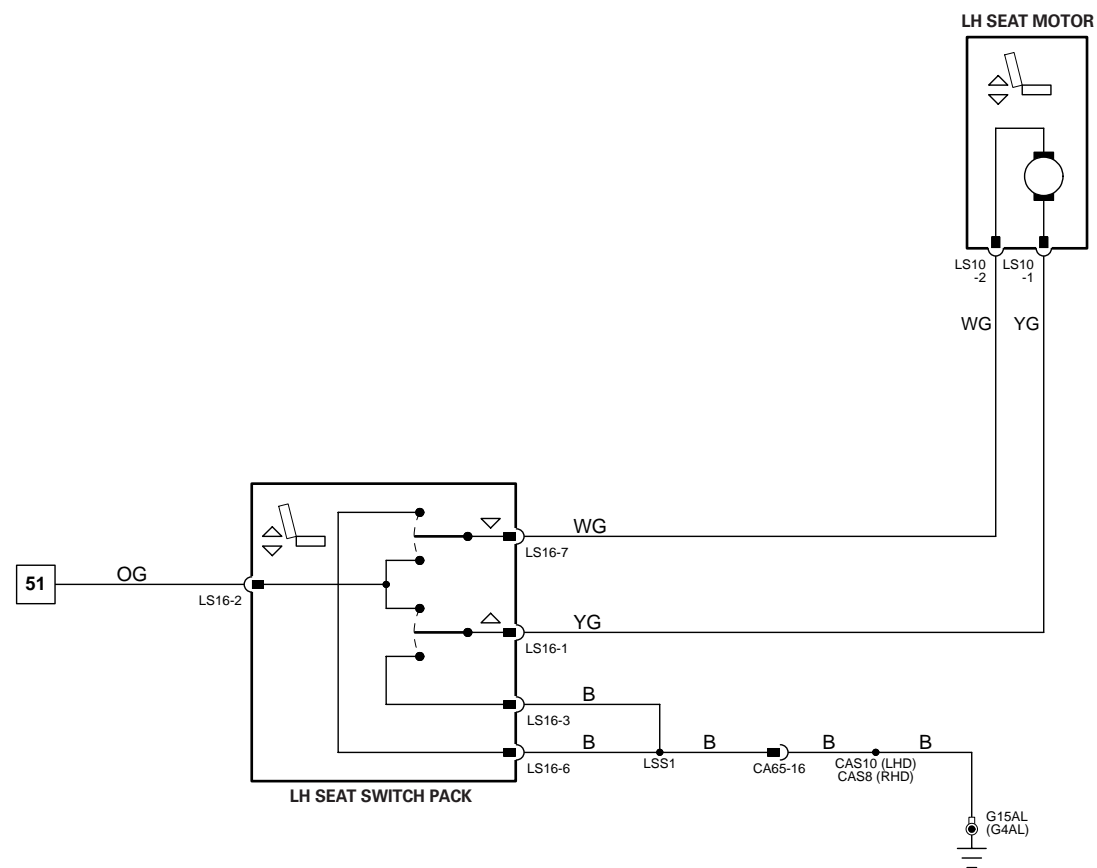

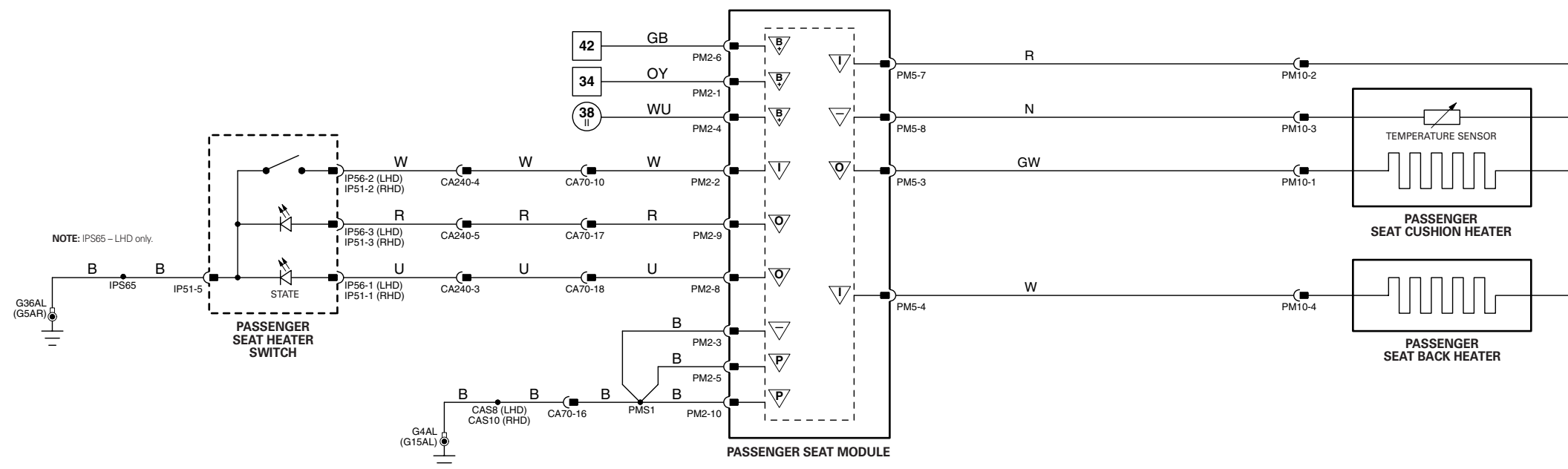
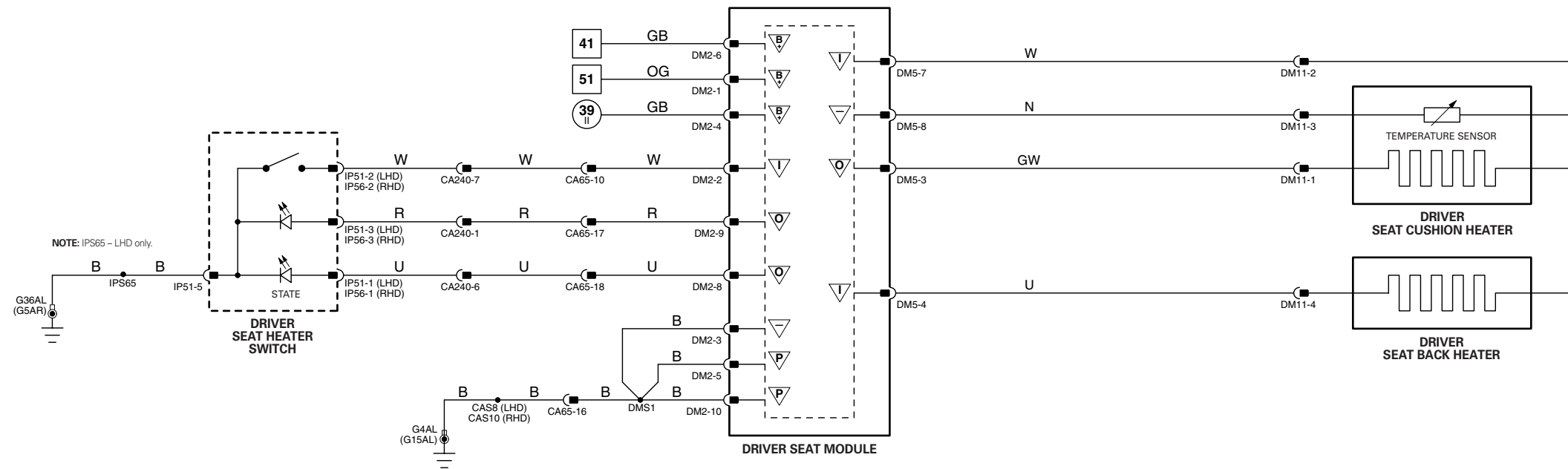

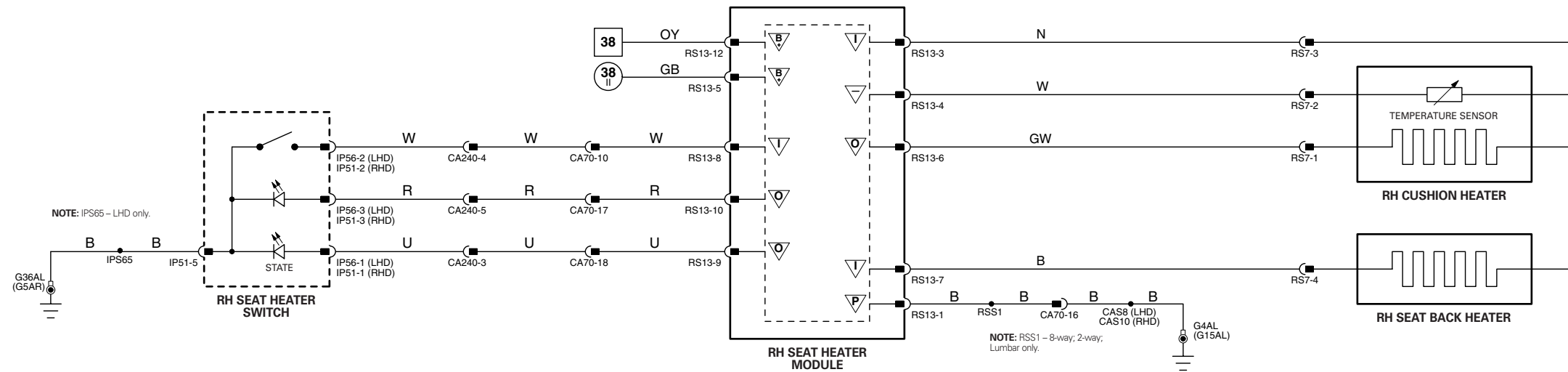
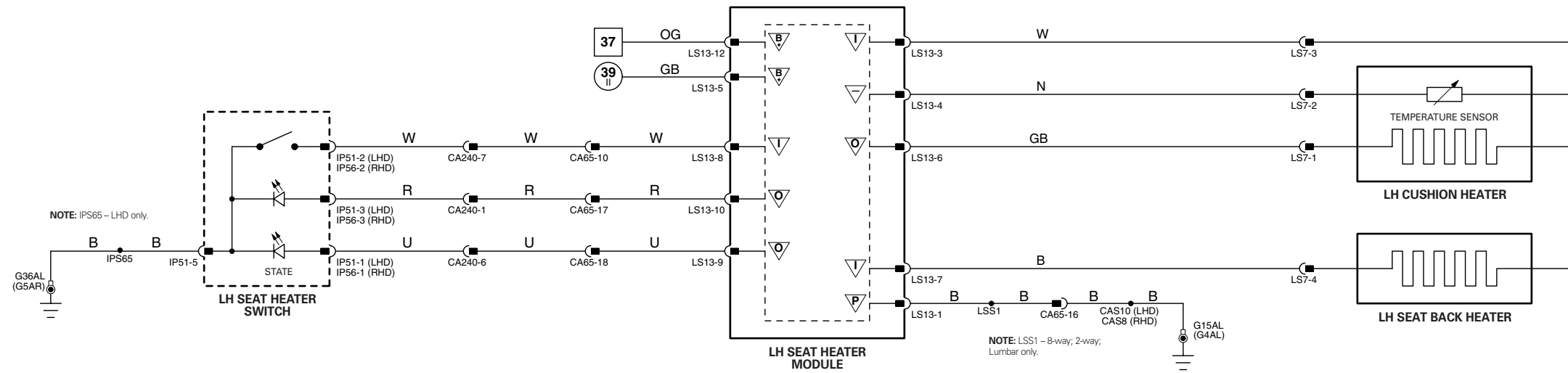

1 → 6 Fig. 01.1

34 → 79 Fig. 01.3

11 → 31 Fig. 01.5

67 → 76 Fig. 01.7

98 → 107 Fig. 01.9

1 → 10 Fig. 01.4

32 → 66 Fig. 01.6

77 → 97 Fig. 01.8

▽ Input

B Battery Voltage

▽ Sensor/Signal Supply V

▽ Sensor/Signal Ground

▽ CAN

▽ D2B Network

▽ SCP

▽ Serial and Encoded Data

VARIANT: Heated Seat Vehicles
VIN RANGE: All
DATE OF ISSUE: June 2003 (PROVISIONAL)



NOTE: Drive-Away Door Locking occurs when all doors are closed, the ignition is switched to II or III and the vehicle speed exceeds 7 k/ph (4 mph).

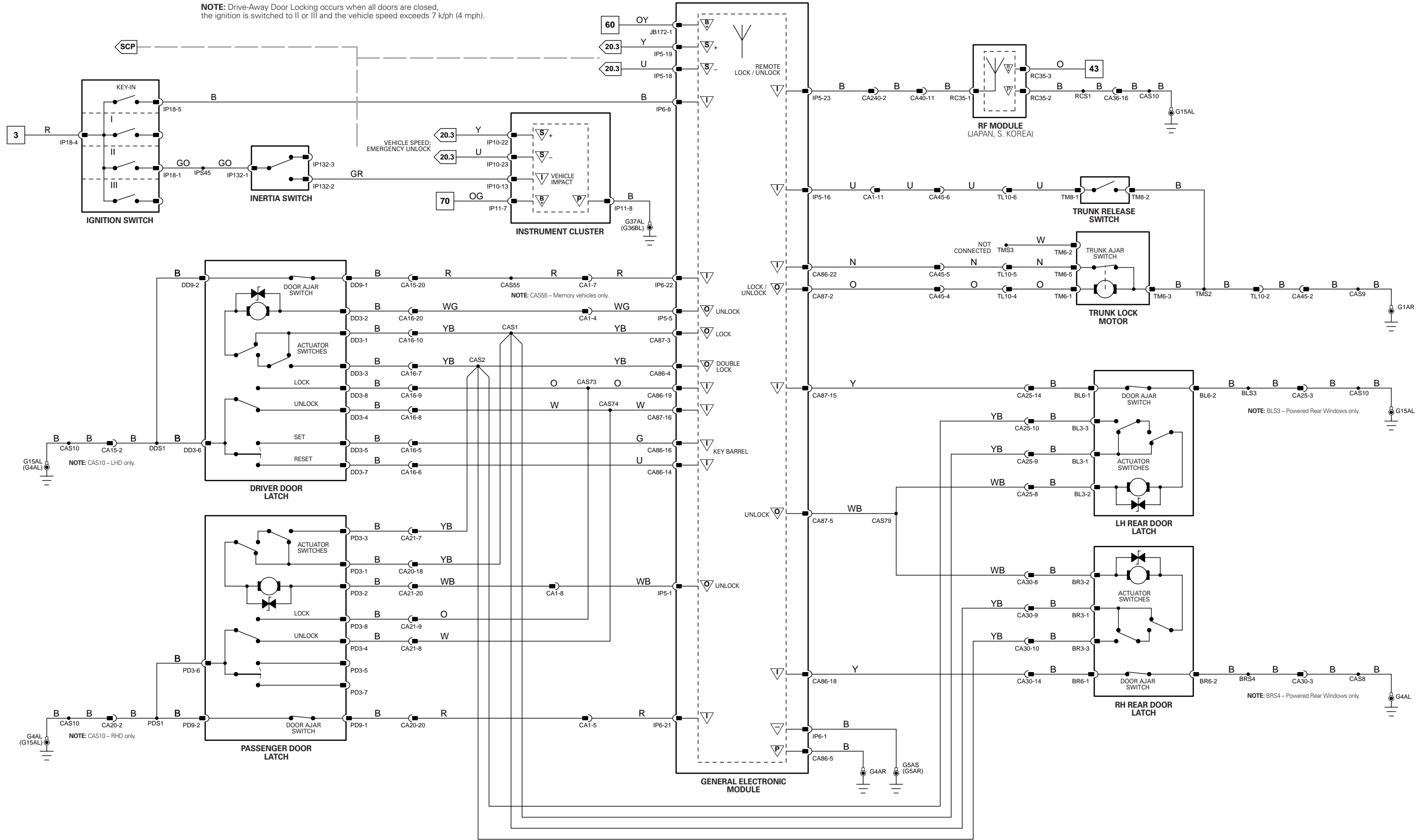



NOTE: Drive-Away Door Locking occurs when all doors are closed, the ignition is switched to II or III and the vehicle speed exceeds 7 k/ph (4 mph).

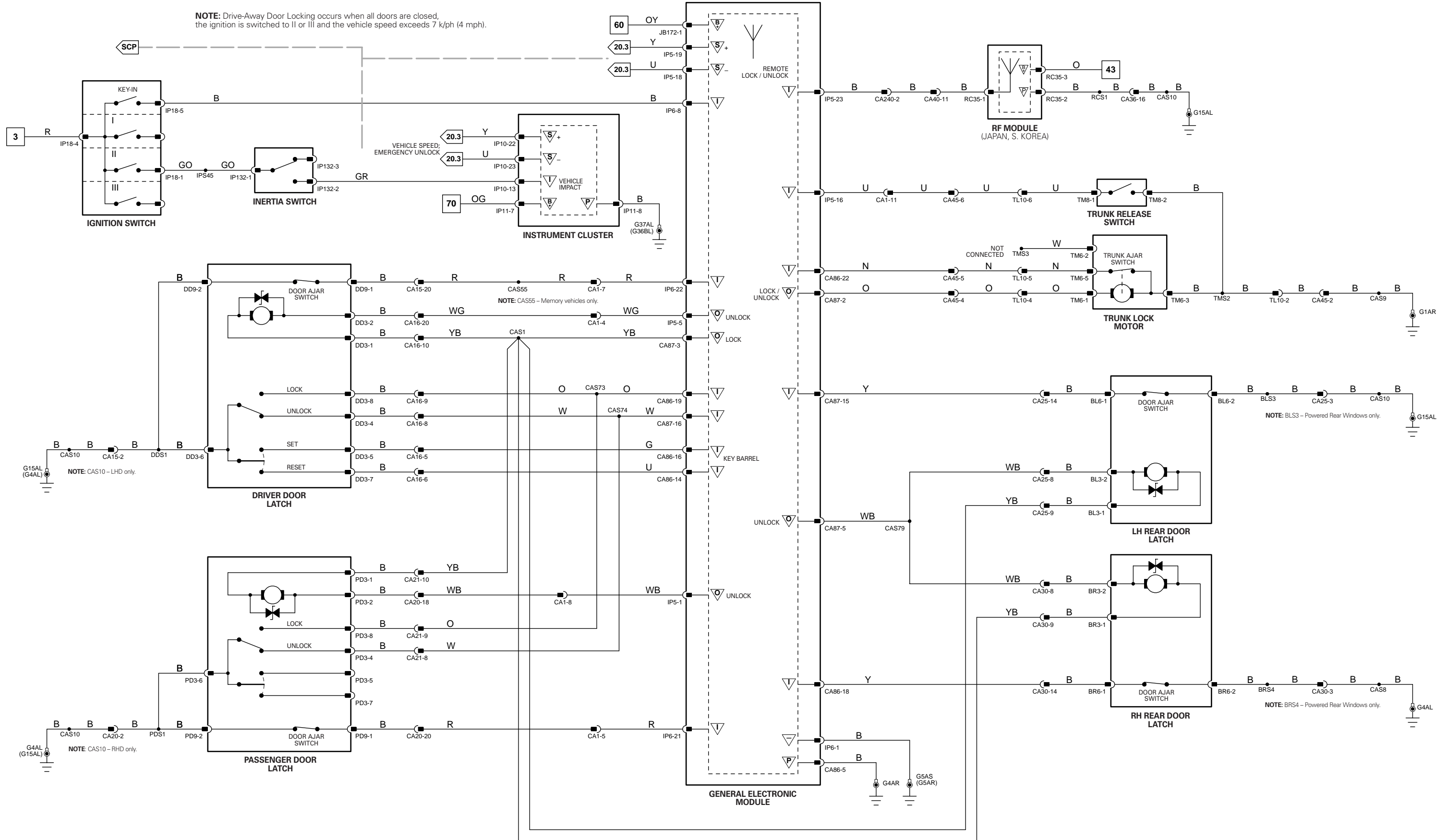



NOTE: Drive-Away Door Locking occurs when all doors are closed, the ignition is switched to II or III and the vehicle speed exceeds 7 k/ph (4 mph).

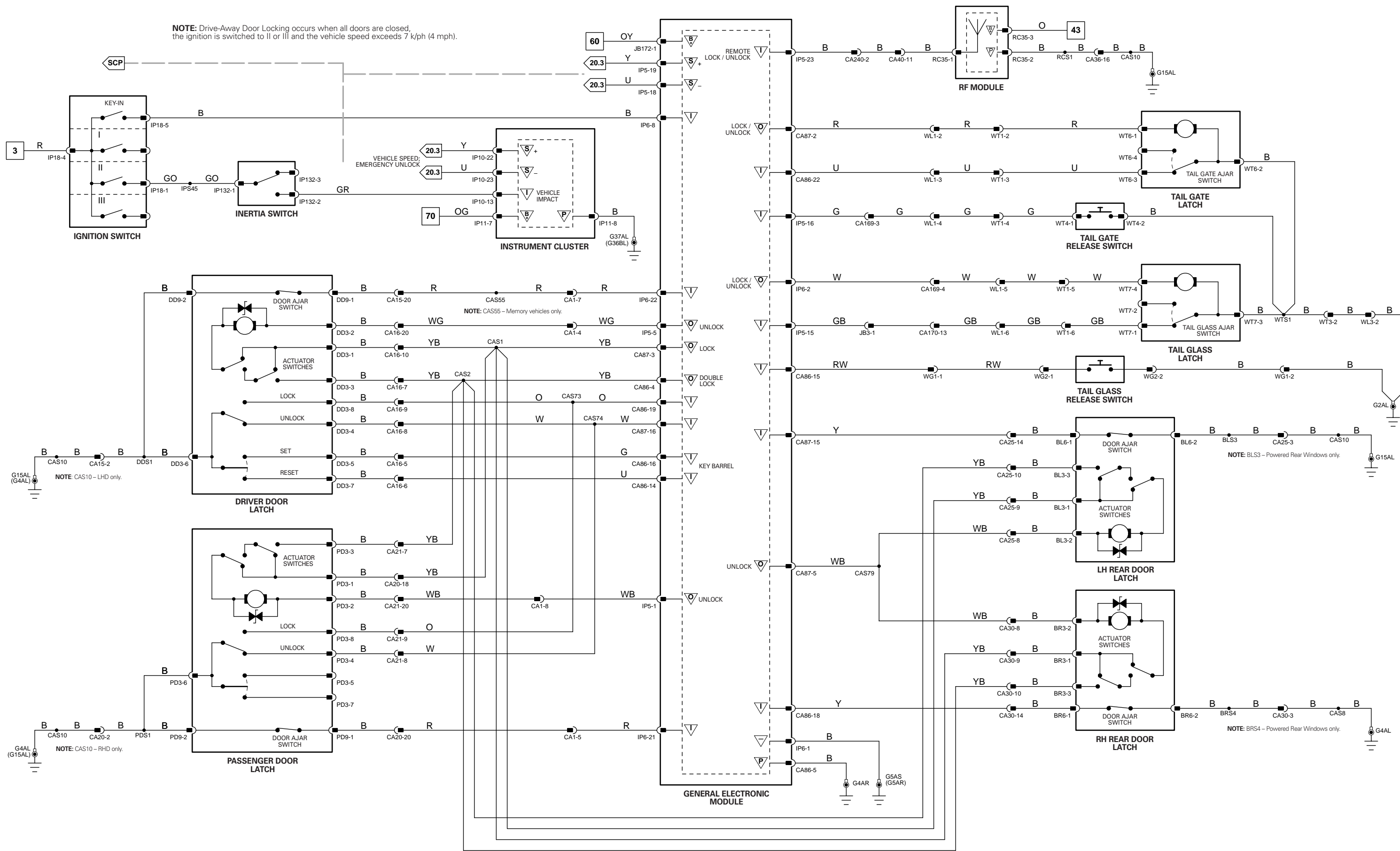

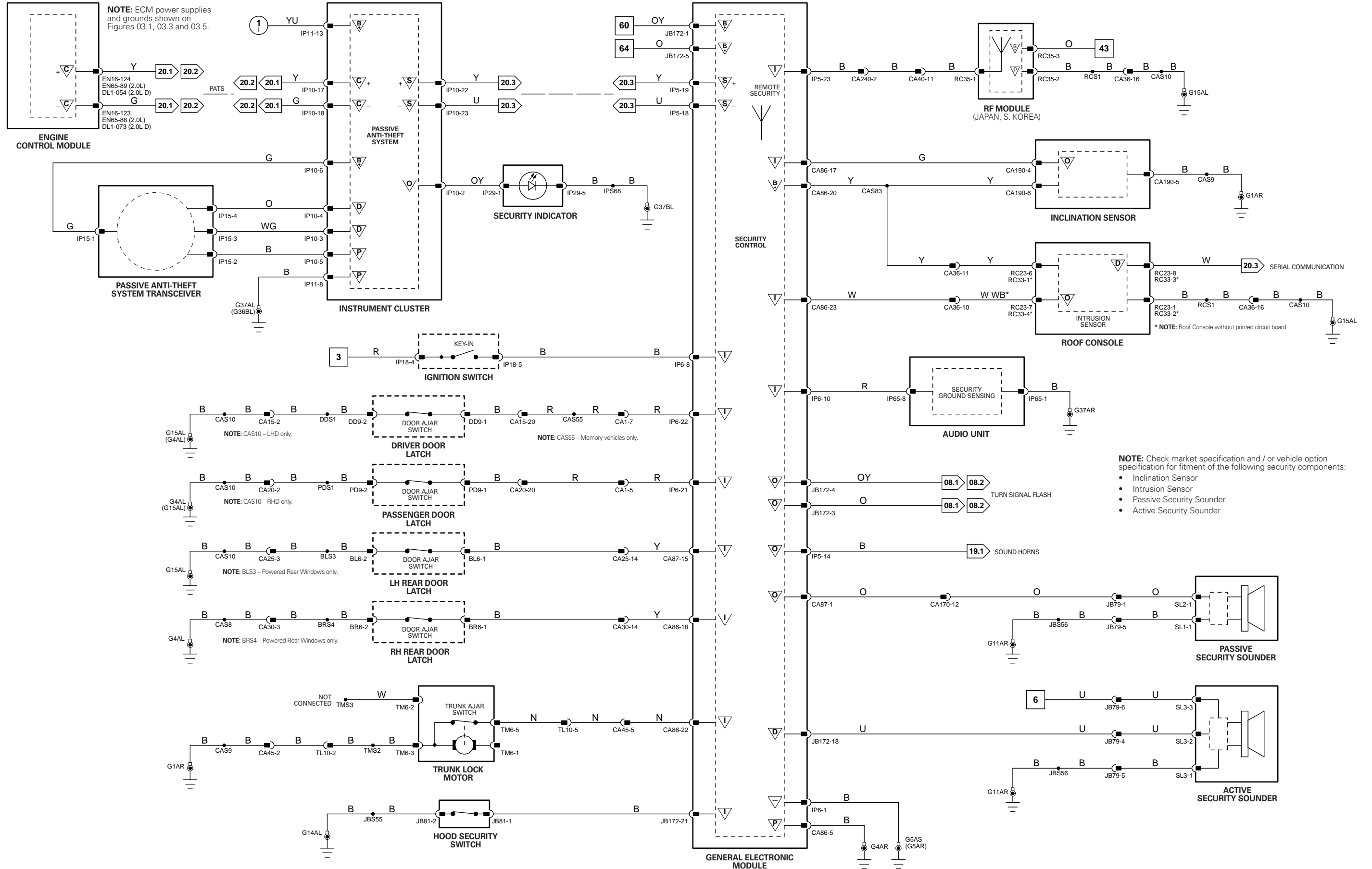

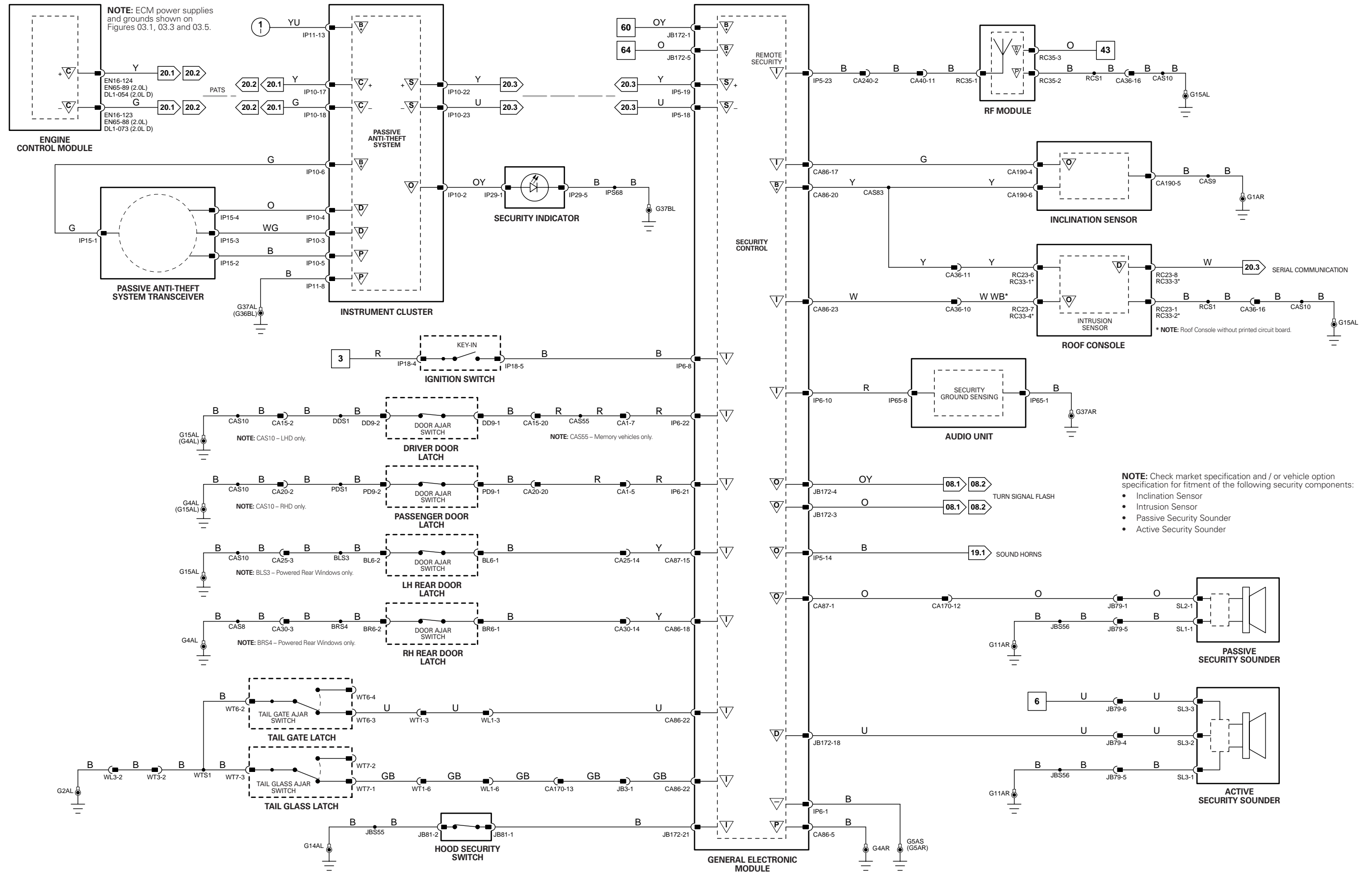

1 → 6 Fig. 01.1	34 → 79 Fig. 01.3	11 → 31 Fig. 01.5	67 → 76 Fig. 01.7	98 → 107 Fig. 01.9	▽ Input	▽ Battery Voltage	▽ Sensor/Signal Supply V	▽ CAN	▽ D2B Network
7 → 33 Fig. 01.2	1 → 10 Fig. 01.4	32 → 66 Fig. 01.6	77 → 97 Fig. 01.8		▽ Output	▽ Power Ground	▽ Sensor/Signal Ground	▽ SCP	▽ Serial and Encoded Data

VARIANT: Sports Brake Vehicles
 VIN RANGE: All
 DATE OF ISSUE: June 2003 (PROVISIONAL)

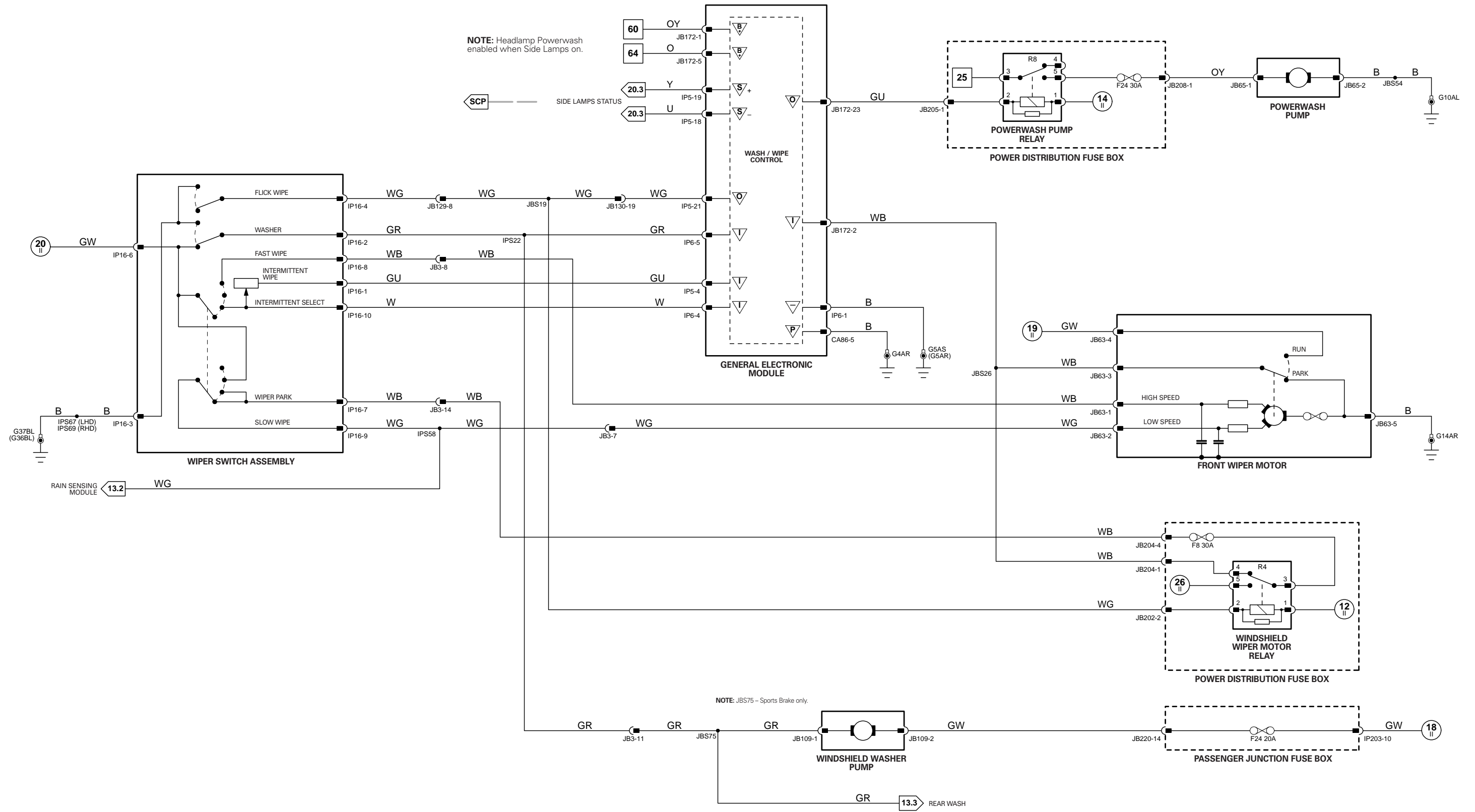

1 → 6 Fig. 01.1	34 → 79 Fig. 01.3	11 → 31 Fig. 01.5	67 → 76 Fig. 01.7	98 → 107 Fig. 01.9	▽ Input	▽ Battery Voltage	▽ Sensor/Signal Supply V	▽ CAN	▽ D2B Network
7 → 33 Fig. 01.2	1 → 10 Fig. 01.4	32 → 66 Fig. 01.6	77 → 97 Fig. 01.8		▽ Output	▽ Power Ground	▽ Sensor/Signal Ground	▽ SCP	▽ Serial and Encoded Data

VARIANT: Non Rain Sensing Vehicles
 VIN RANGE: All
 DATE OF ISSUE: June 2003 (PROVISIONAL)

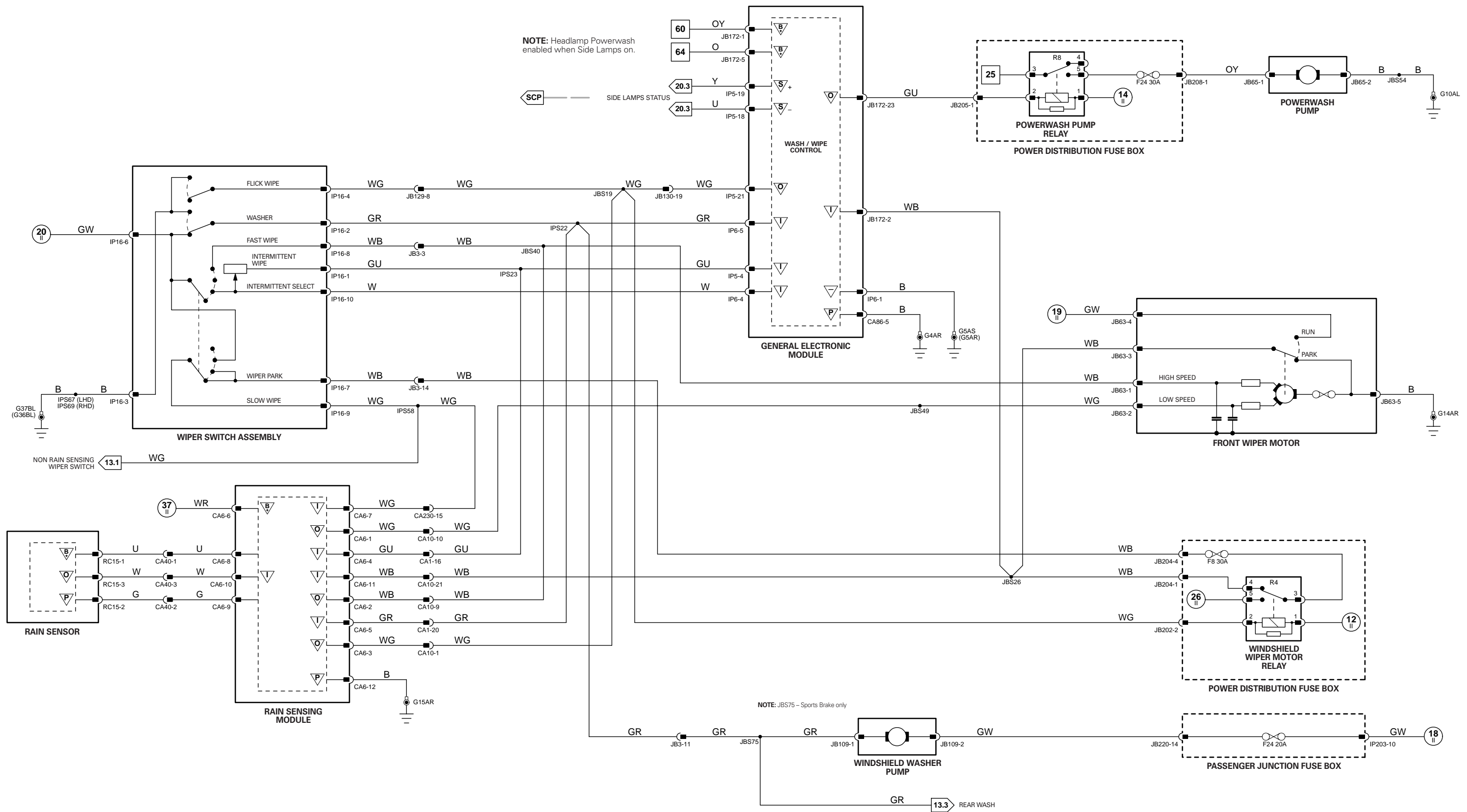

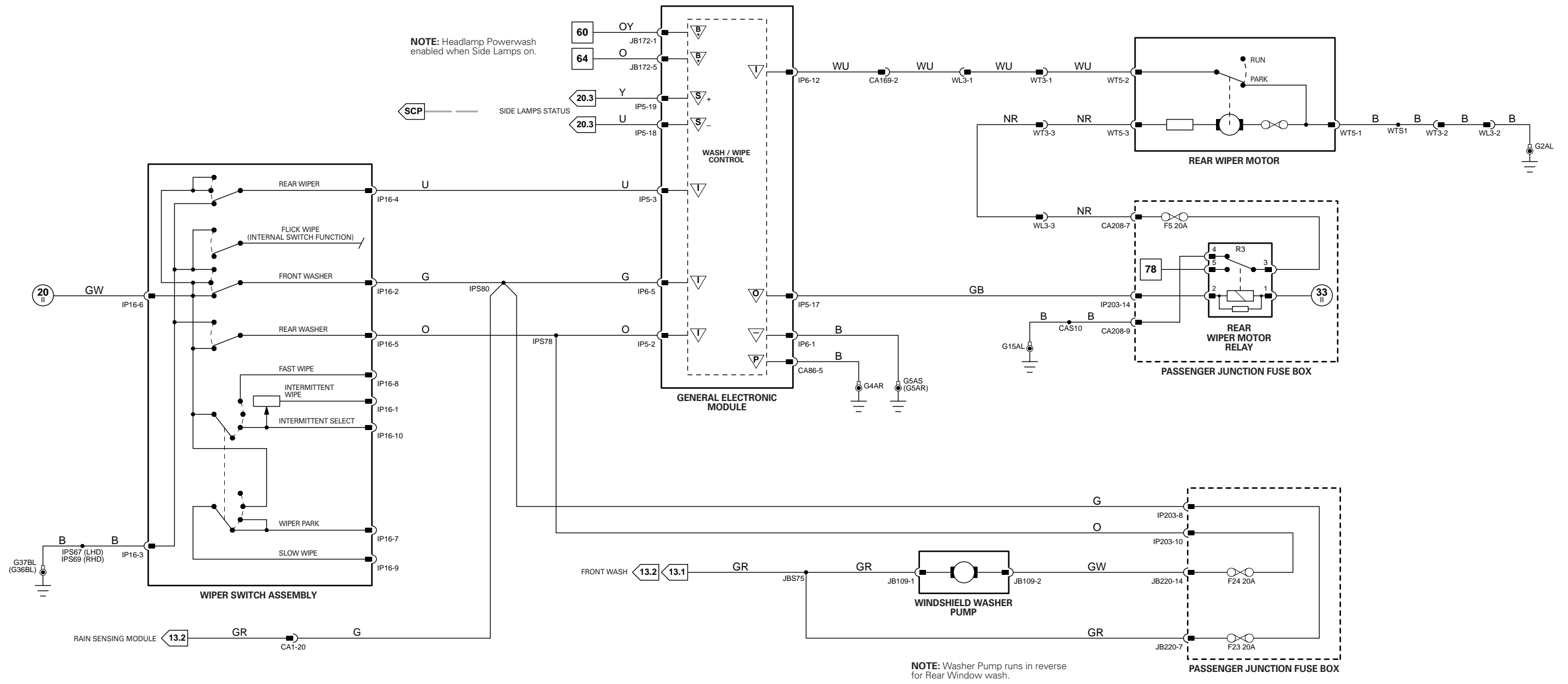

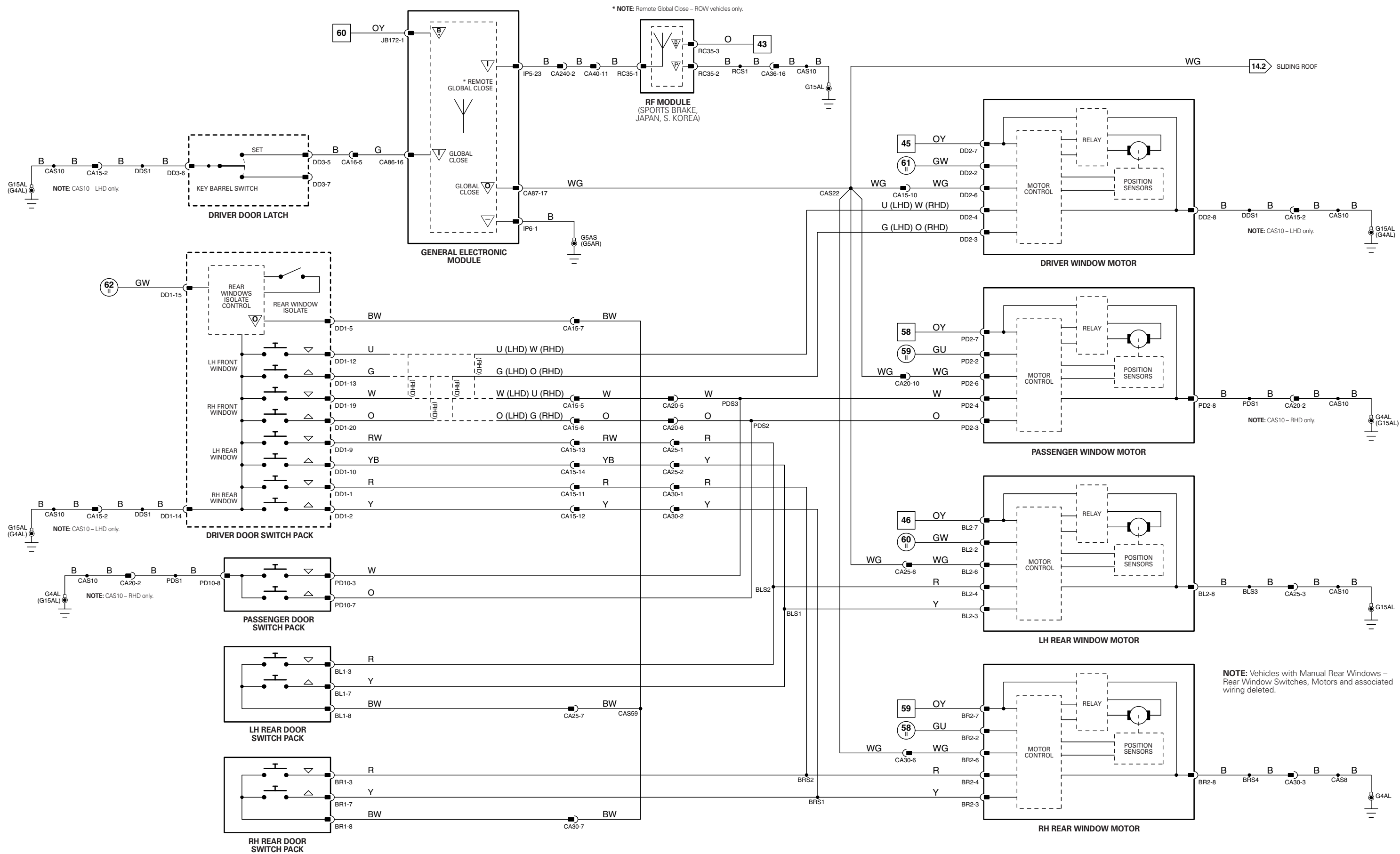

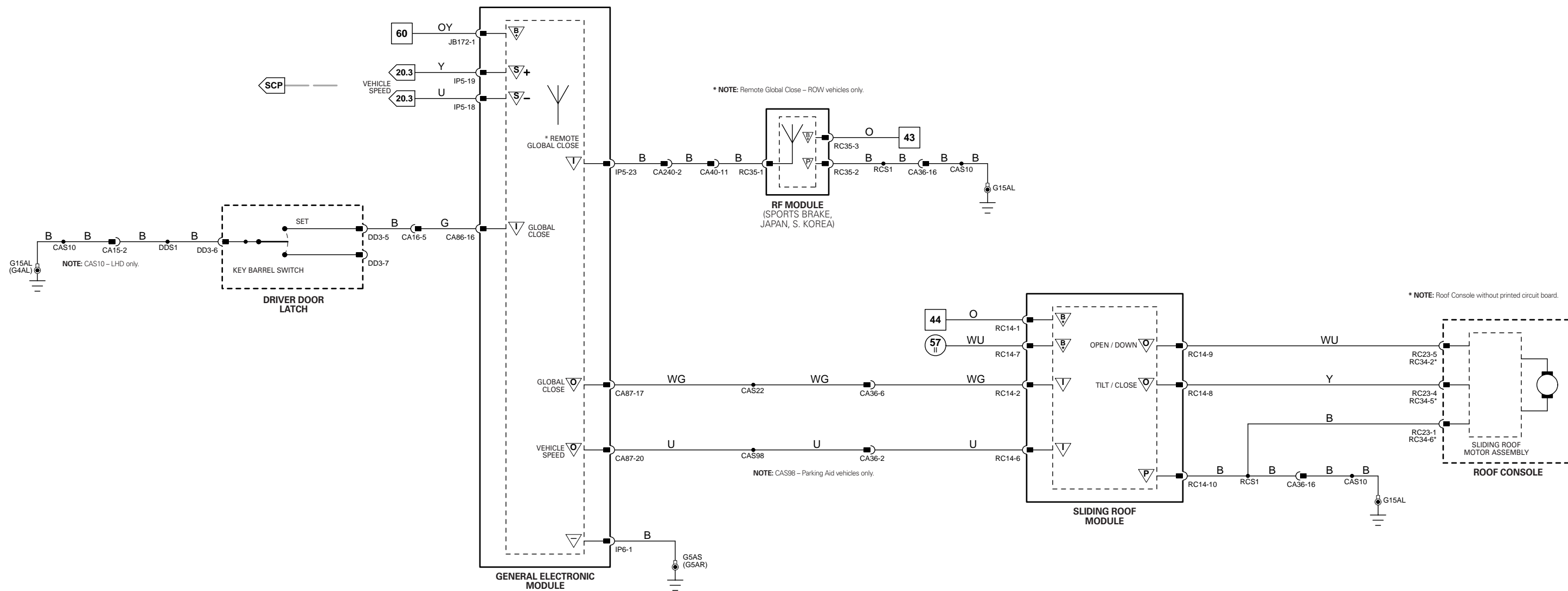

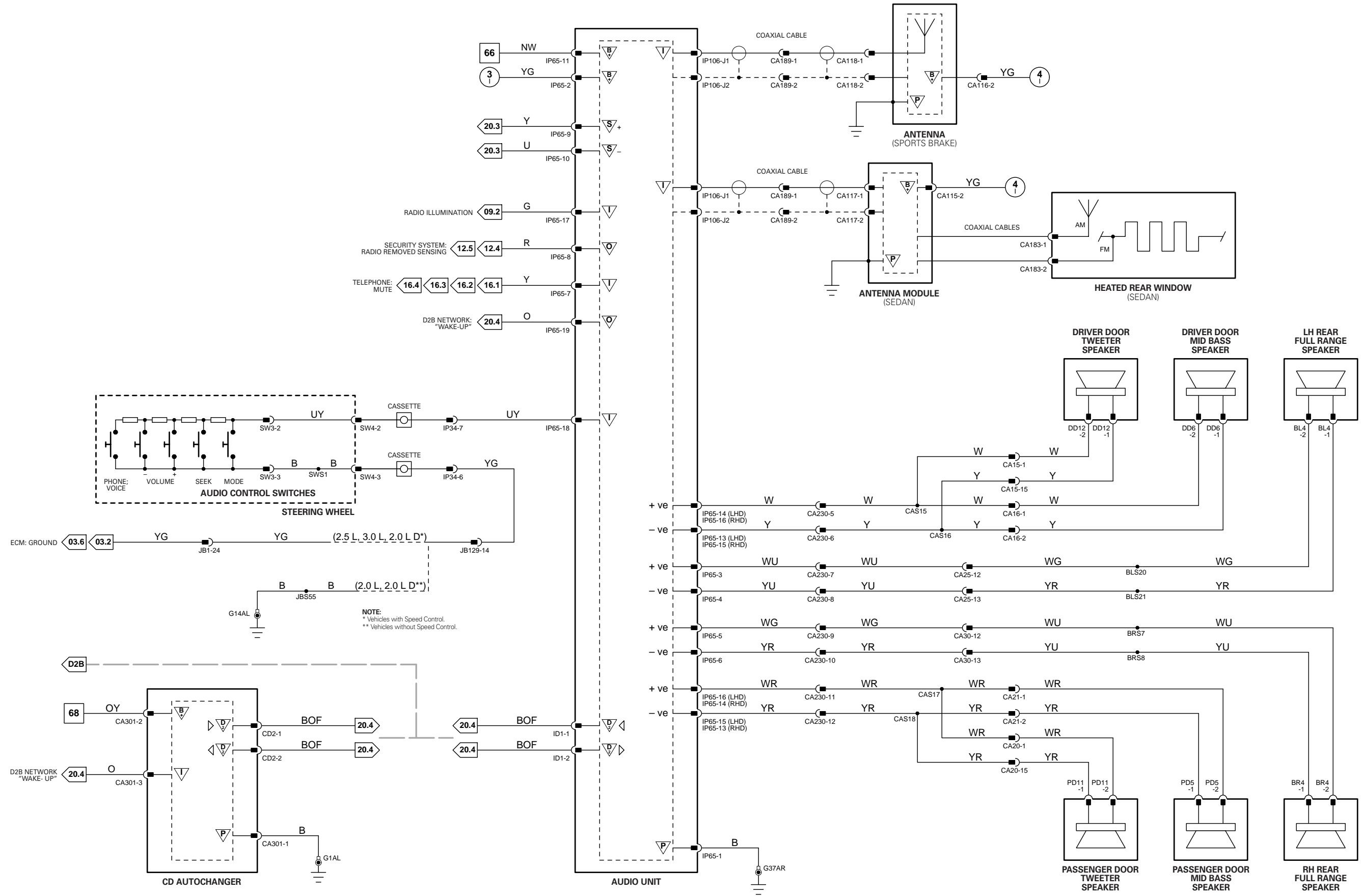

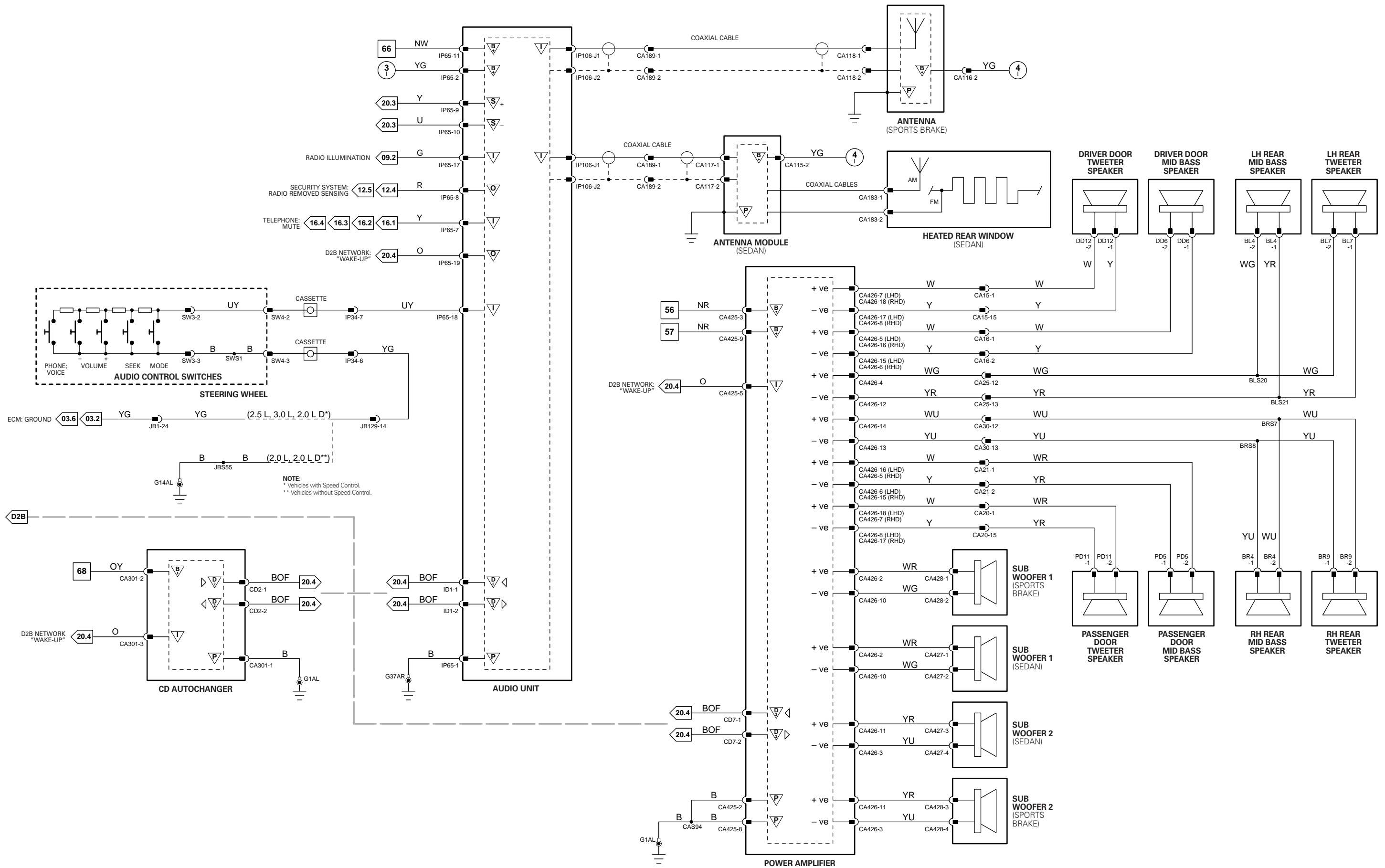

1 → 6	34 → 79	11 → 31	67 → 76	98 → 107	Input	Battery Voltage	Sensor/Signal Supply V	CAN	D2B Network
7 → 33	1 → 10	32 → 66	77 → 97		Output	Power Ground	Sensor/Signal Ground	SCP	Serial and Encoded Data

VARIANT: Premium ICE Vehicles
VIN RANGE: All
DATE OF ISSUE: June 2003 (PROVISIONAL)

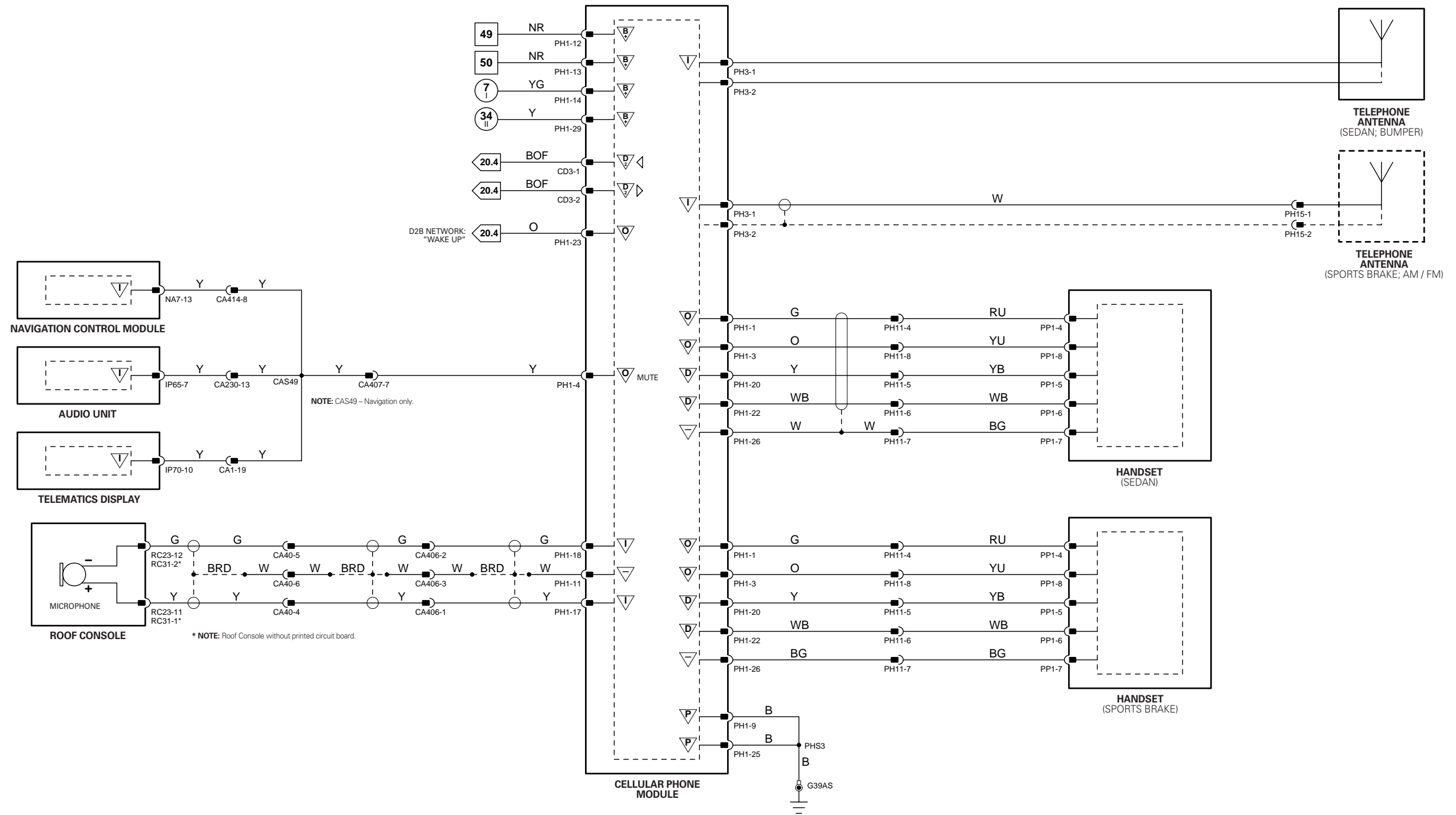

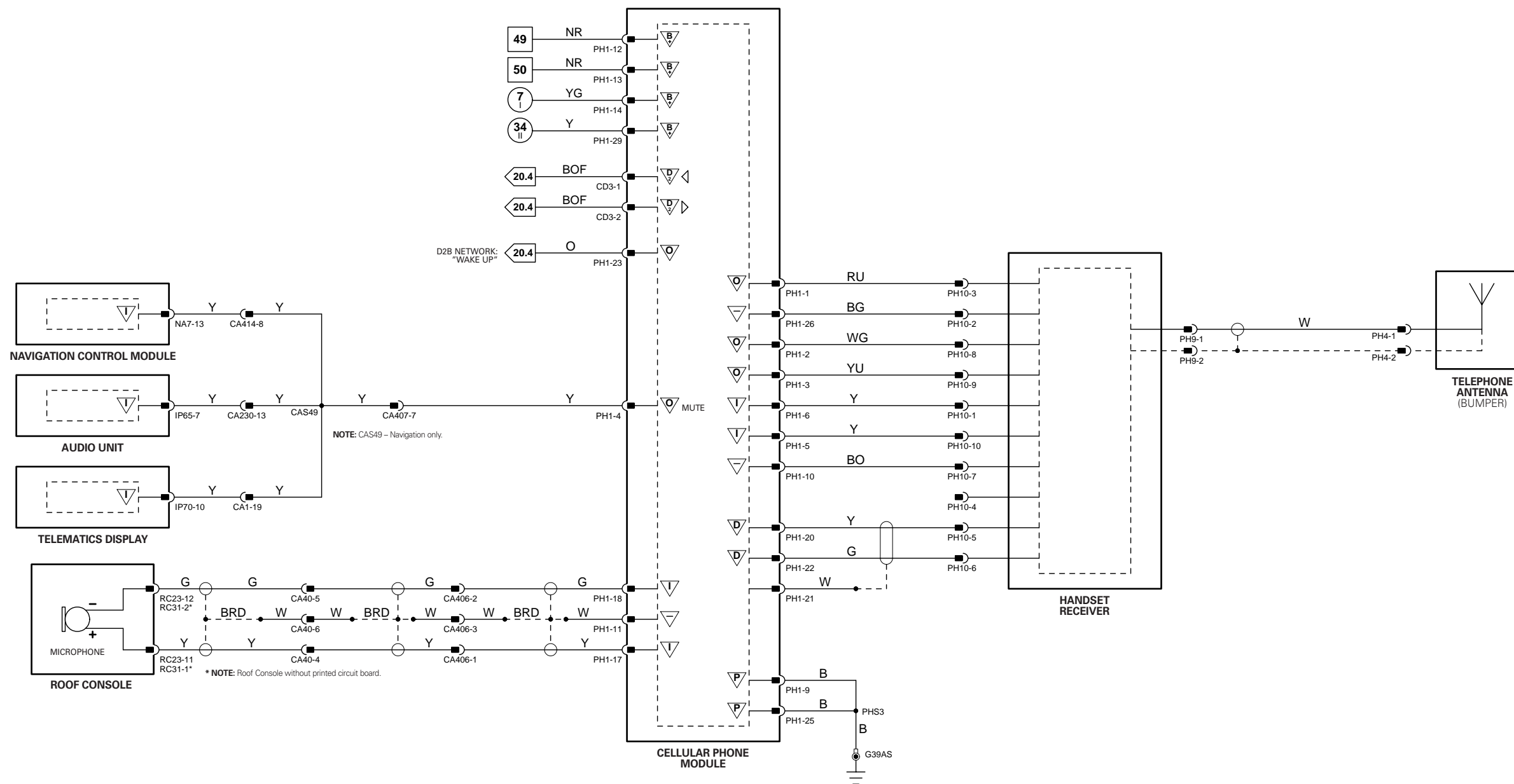

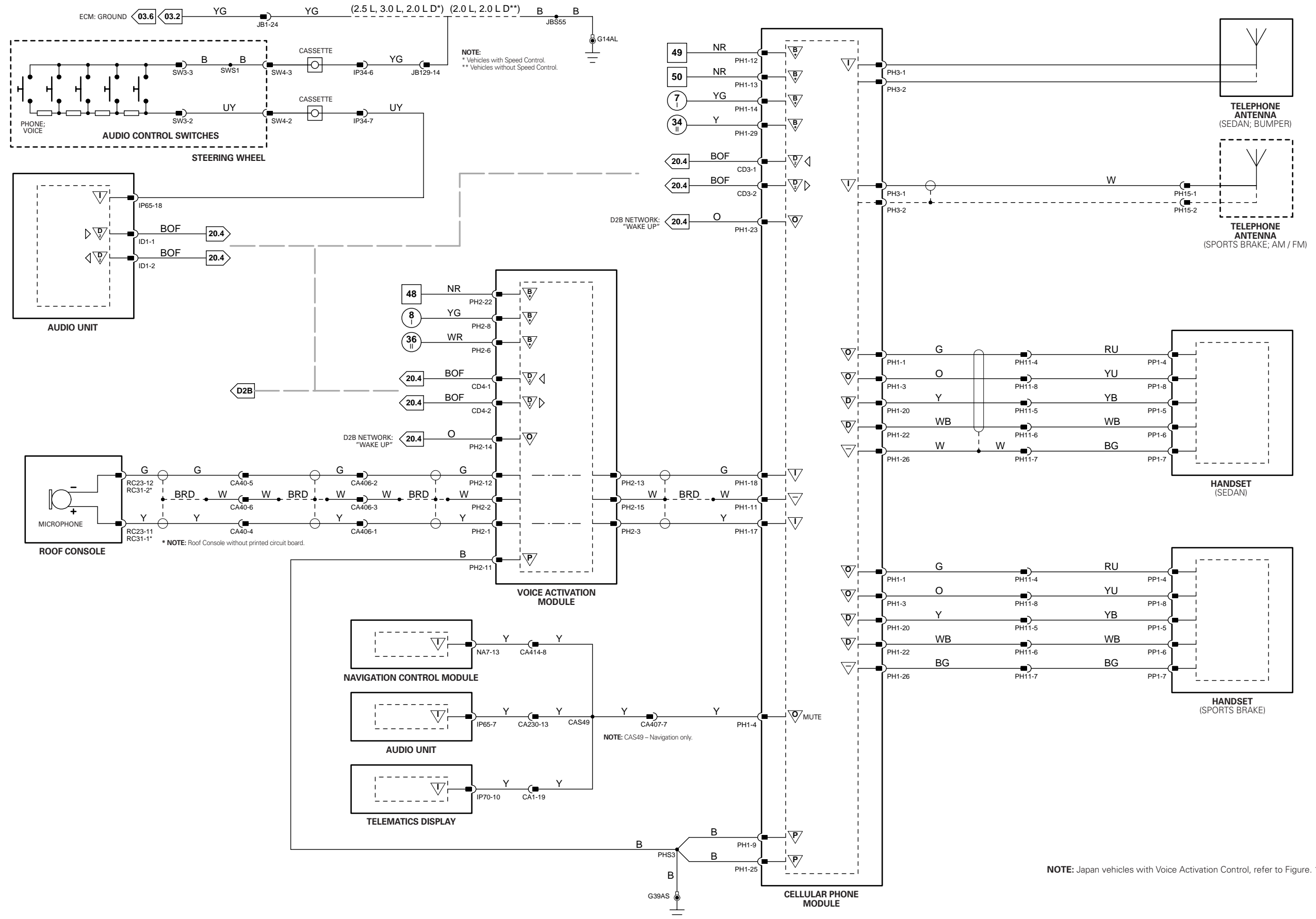

NOTE: Japan vehicles with Voice Activation Control, refer to Figure. 16.6.

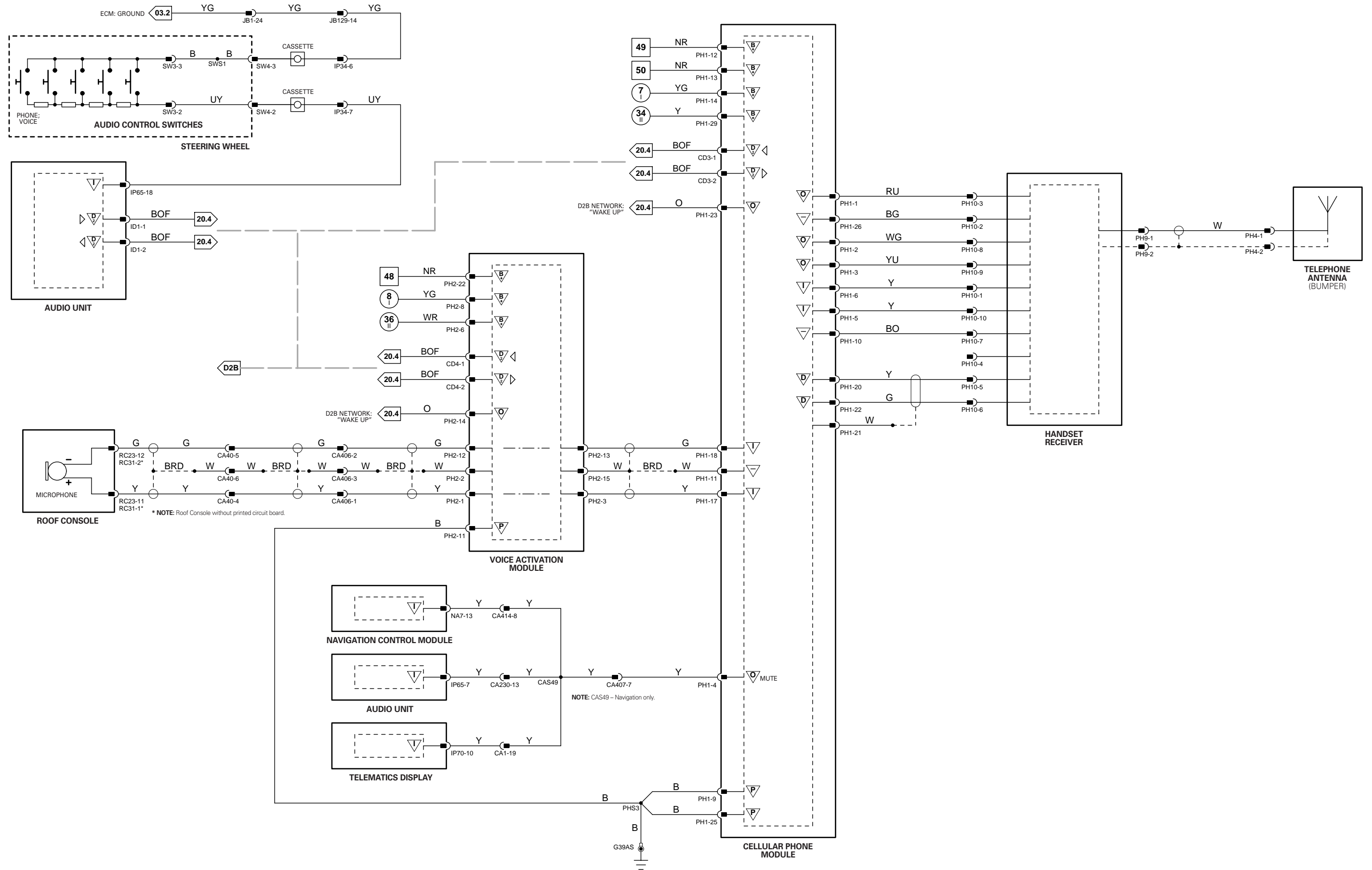

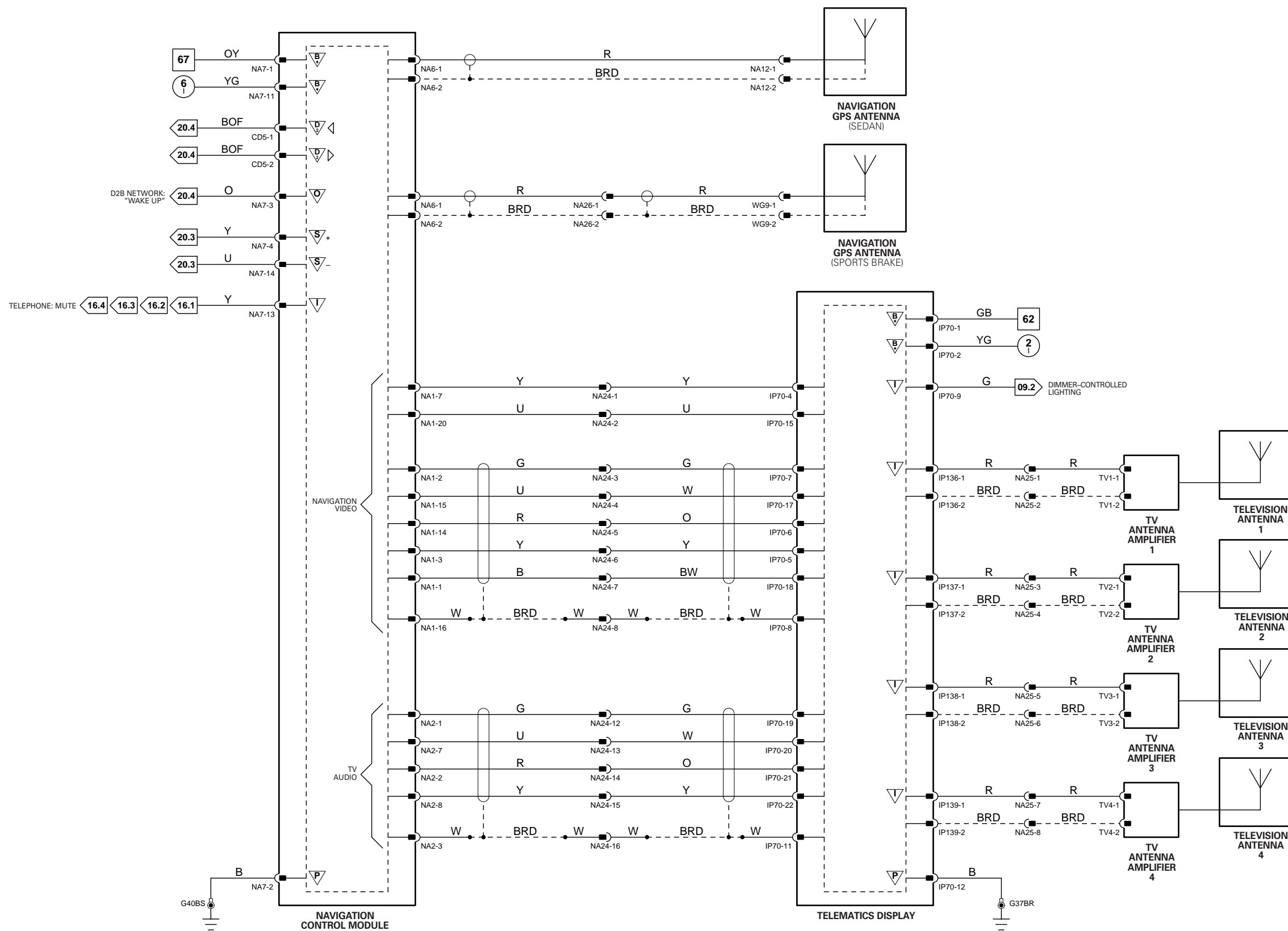

1 → 6 Fig. 01.1

34 → 79 Fig. 01.3

11 → 31 Fig. 01.5

67 → 76 Fig. 01.7

98 → 107 Fig. 01.9

7 → 33 Fig. 01.2

1 → 10 Fig. 01.4

32 → 66 Fig. 01.6

77 → 97 Fig. 01.8

▽ Input

⏏ Battery Voltage

▽ Sensor/Signal Supply V

▽ CAN

⏏ D2B Network

▽ Output

⏏ Power Ground

▽ Sensor/Signal Ground

▽ SCP

▽ Serial and Encoded Data

VARIANT: NAV Vehicles (except Japan)
VIN RANGE: All
DATE OF ISSUE: June 2003 (PROVISIONAL)

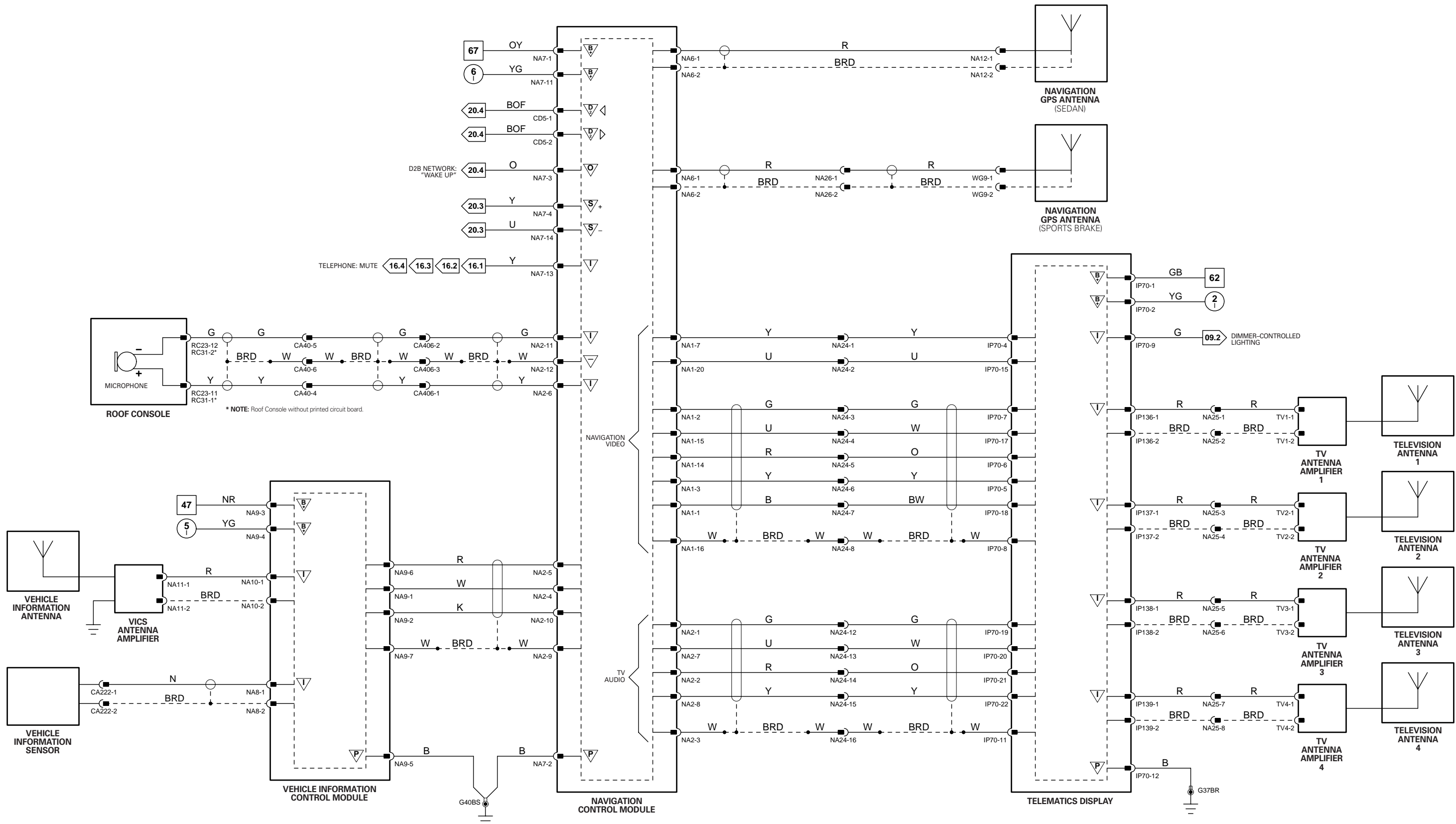

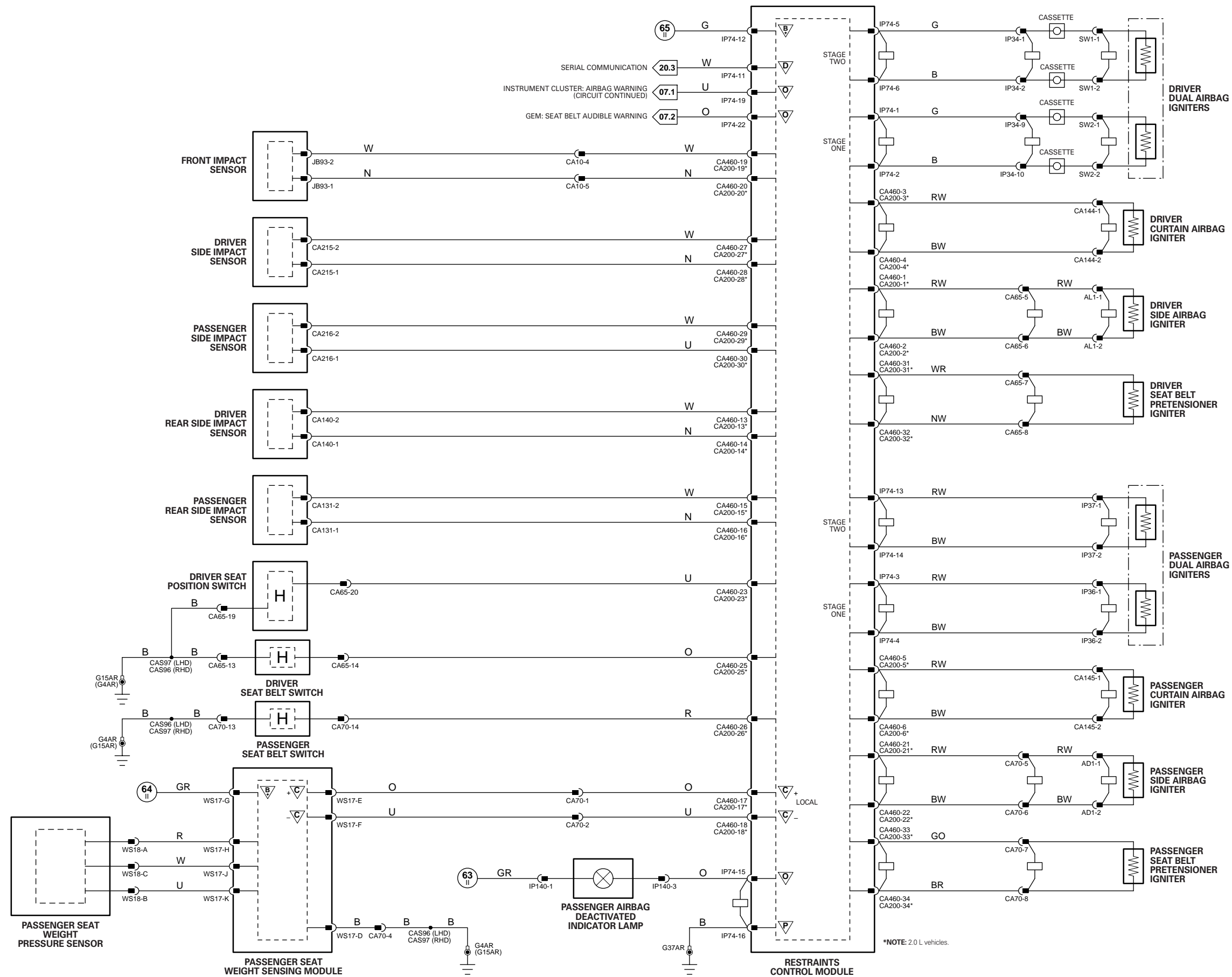

*NOTE: 2.0 L vehicles.

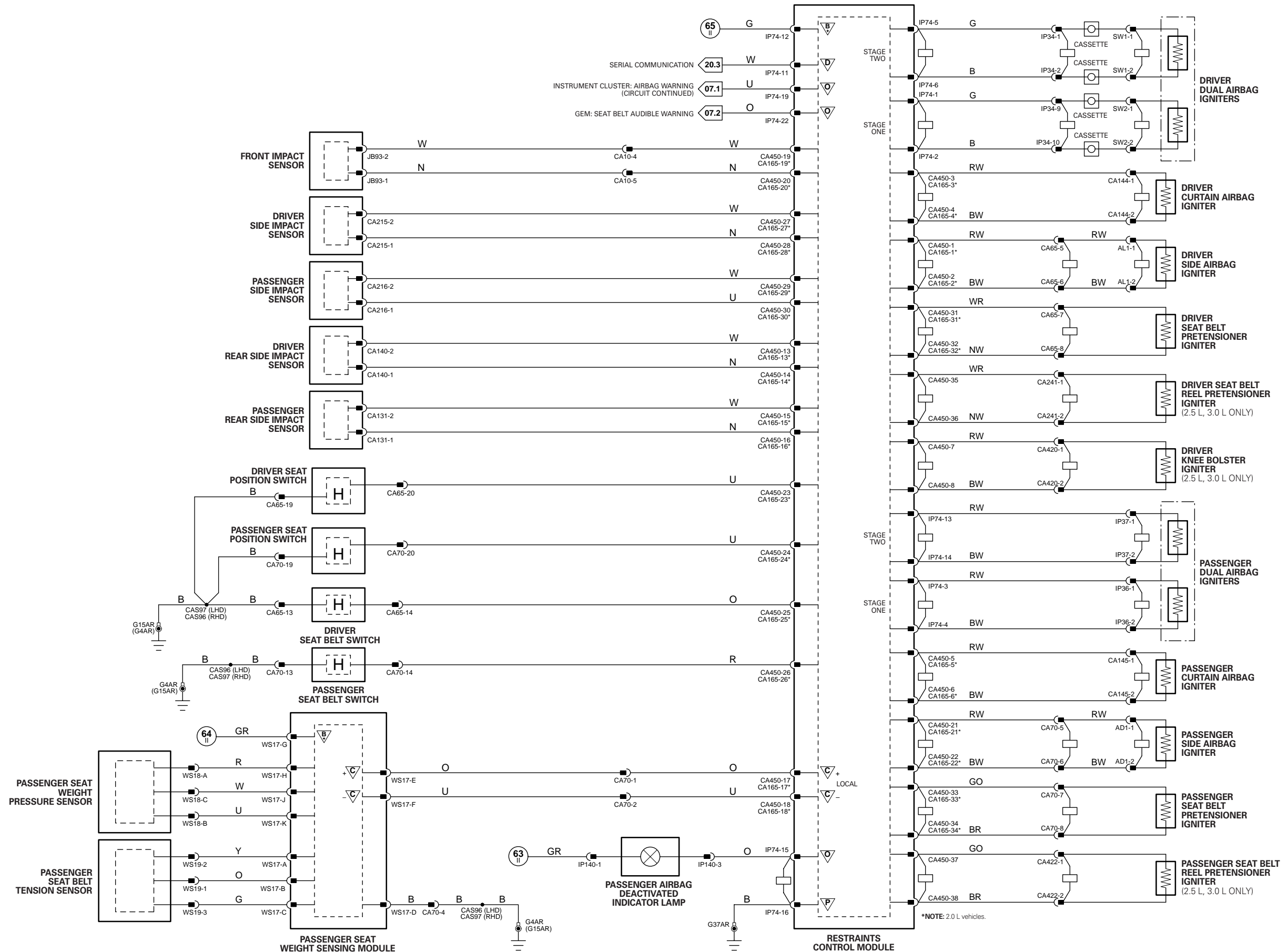

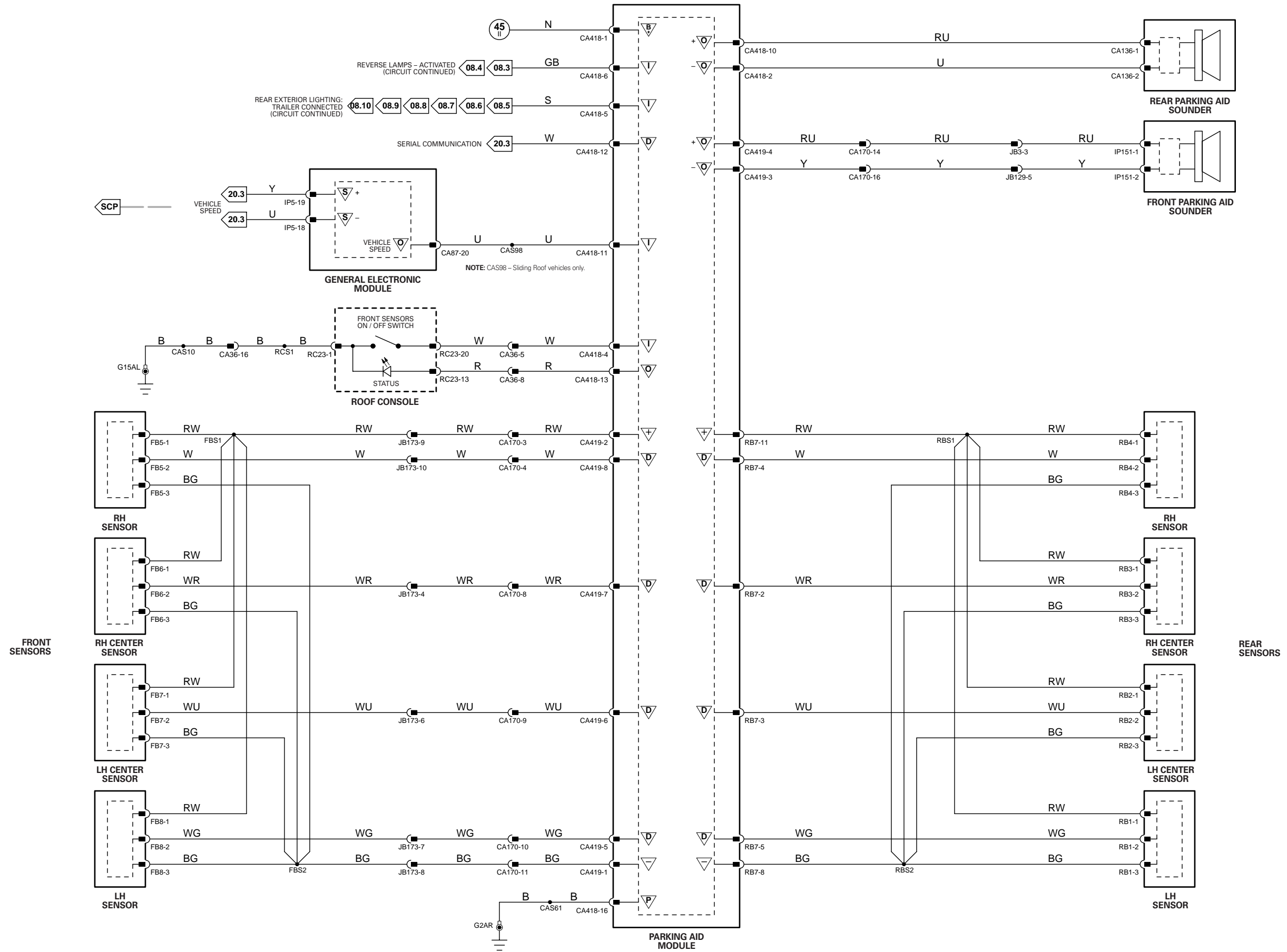

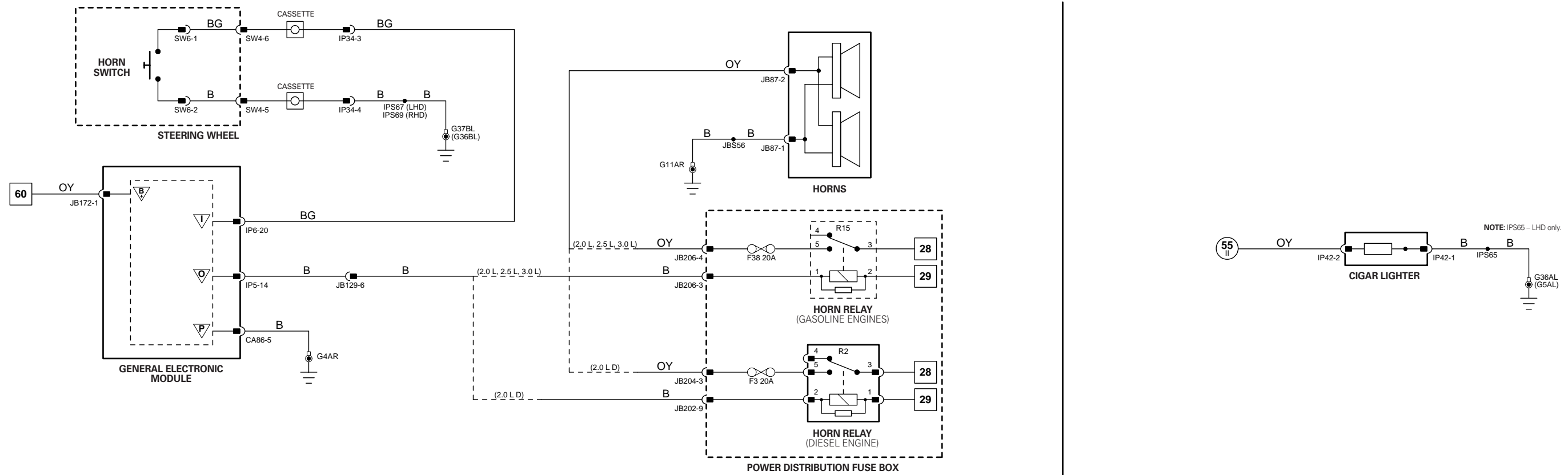

HORN

CIGAR LIGHTER

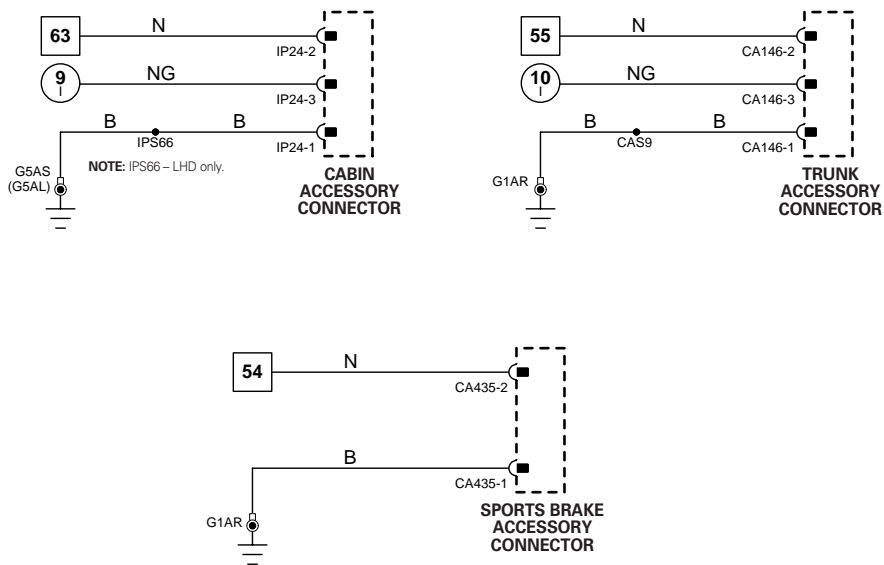

ACCESSORY CONNECTORS

GARAGE DOOR OPENER

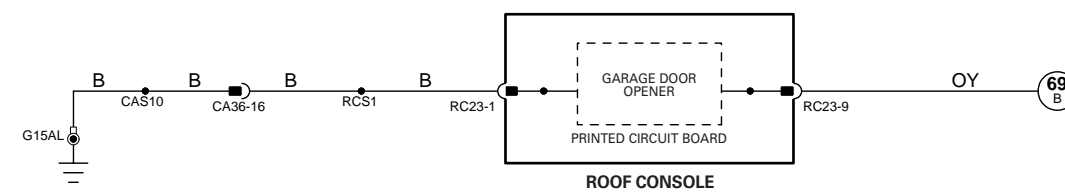

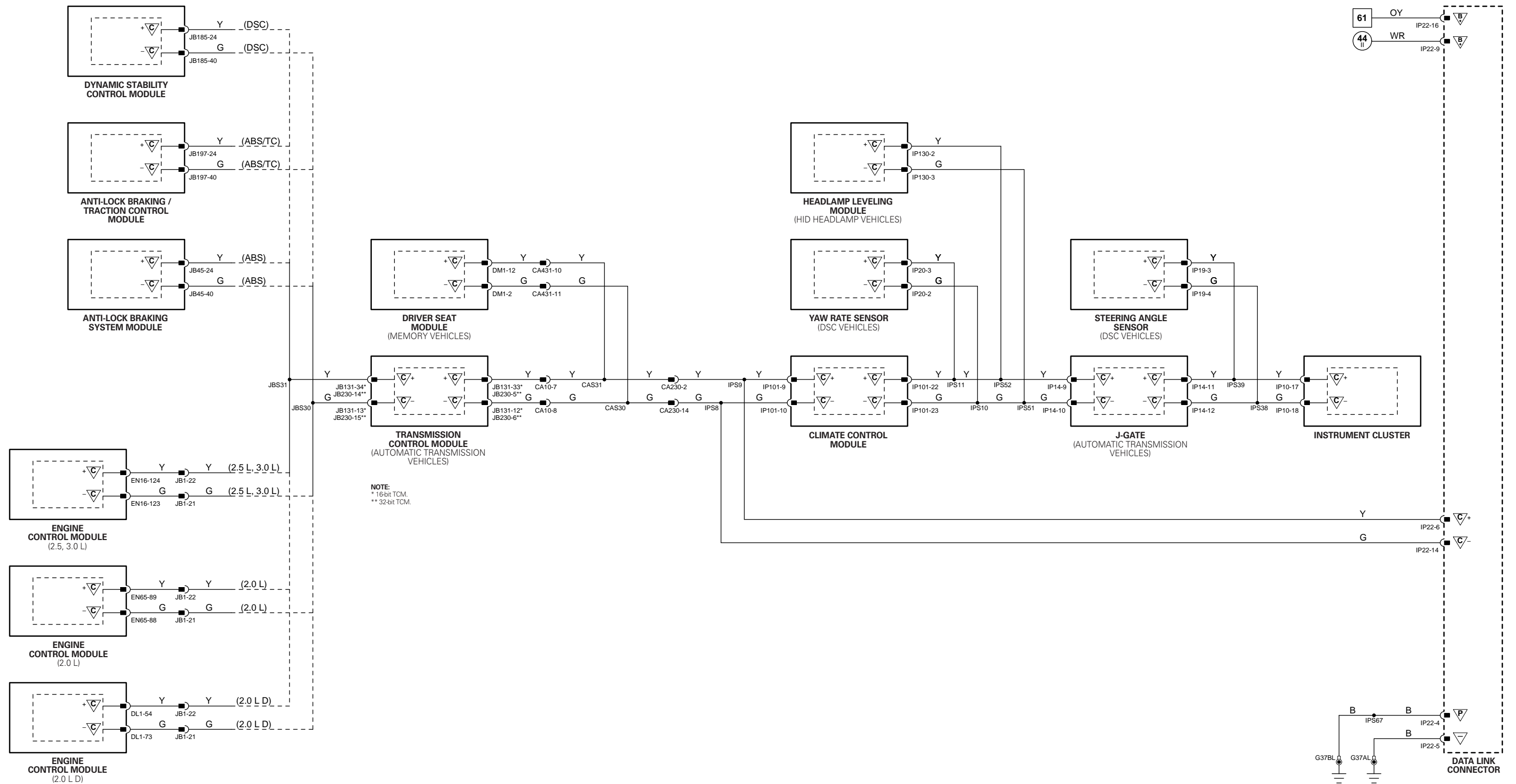

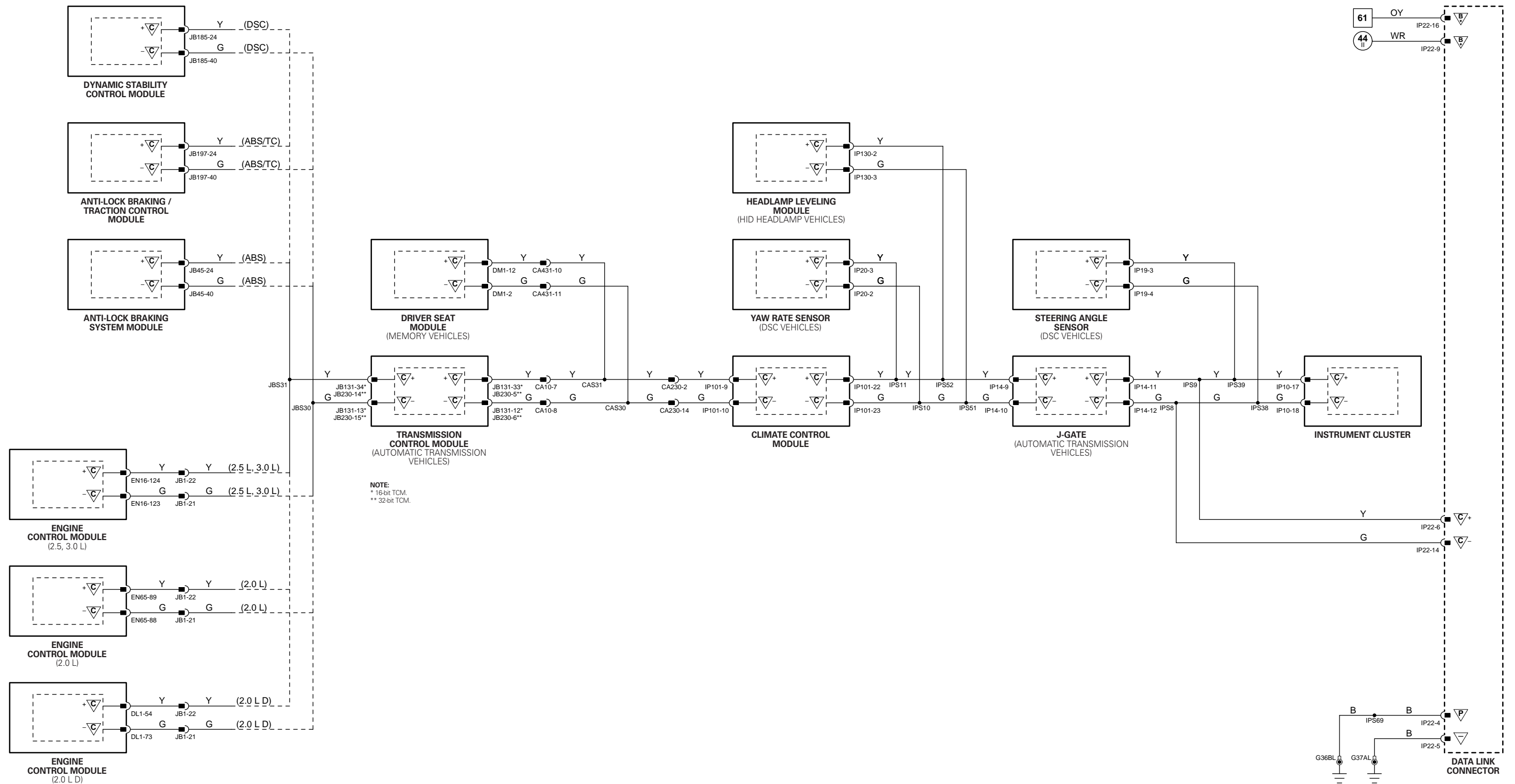



NOTE: D2B Network diagnostics are accessed via the SCP Network.

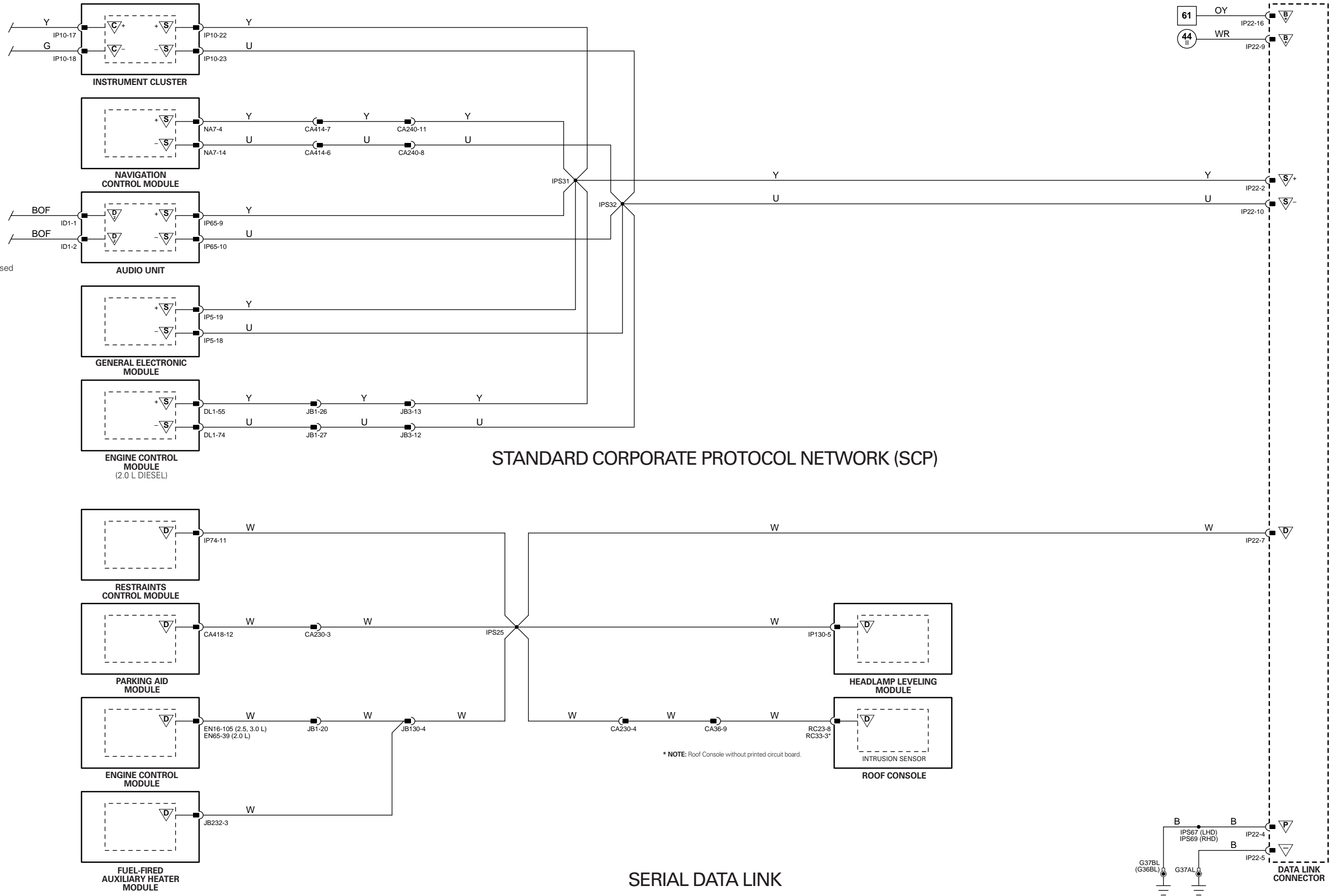

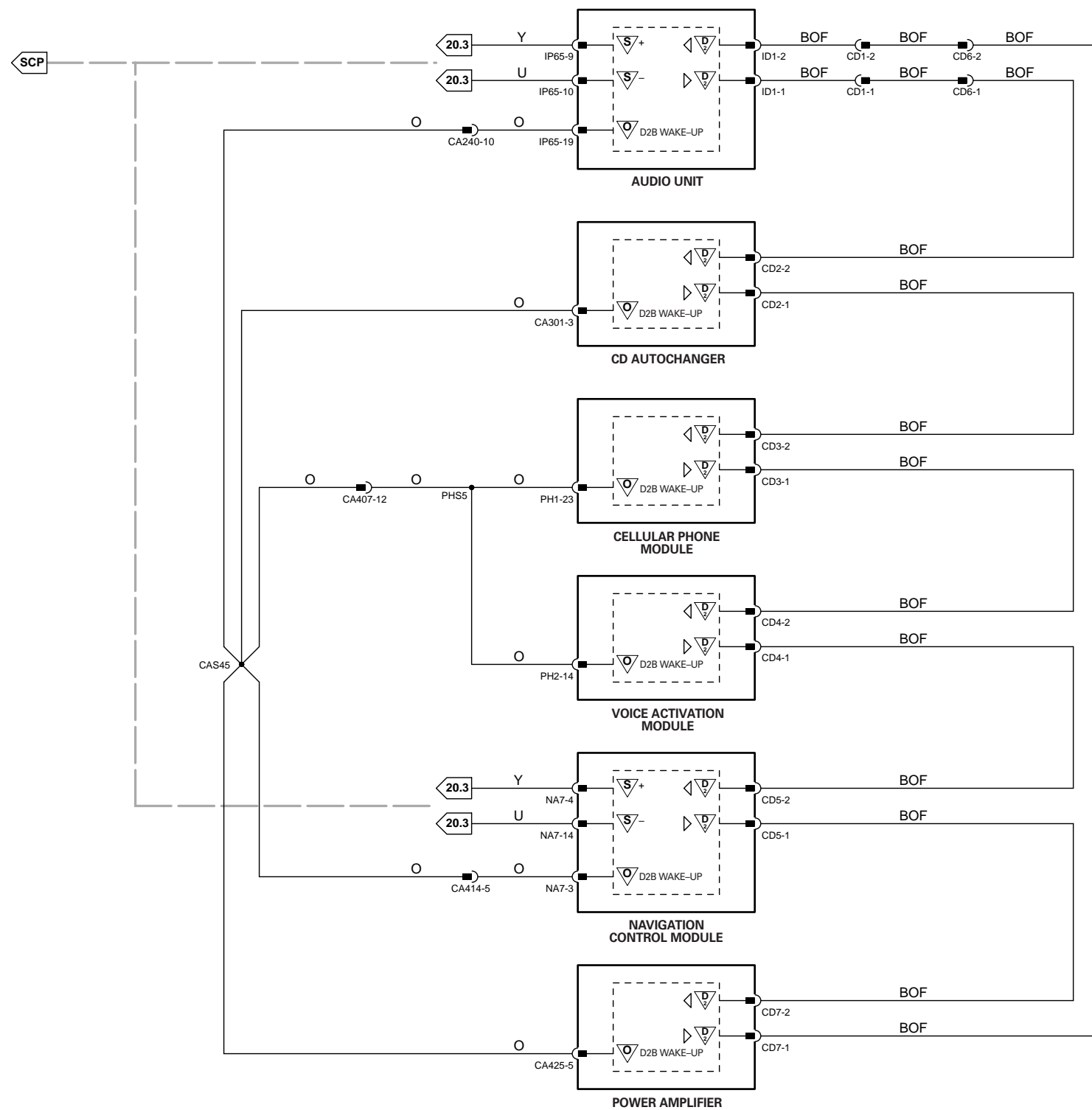

NOTES:

The 6-module D2B Network shown depicts the greatest number of modules available. D2B Networks containing less than 6 modules are always connected in the sequence shown from top to bottom.

- Audio Unit – Master Module
- 1 – CD Autochanger
- 2 – Cellular Phone Module
- 3 – Voice Activation Module
- 4 – Navigation Control Module
- 5 – Power Amplifier

When modules are not fitted to the vehicle, the fiber optic cables and the connectors are deleted. Therefore, each Network containing less than 6 modules has a unique fiber optic and "wake up" circuit.

D2B Network diagnostics via SCP Network – refer to Figure 20.3.