

Efficient and dynamic

Transmission technology from ZF

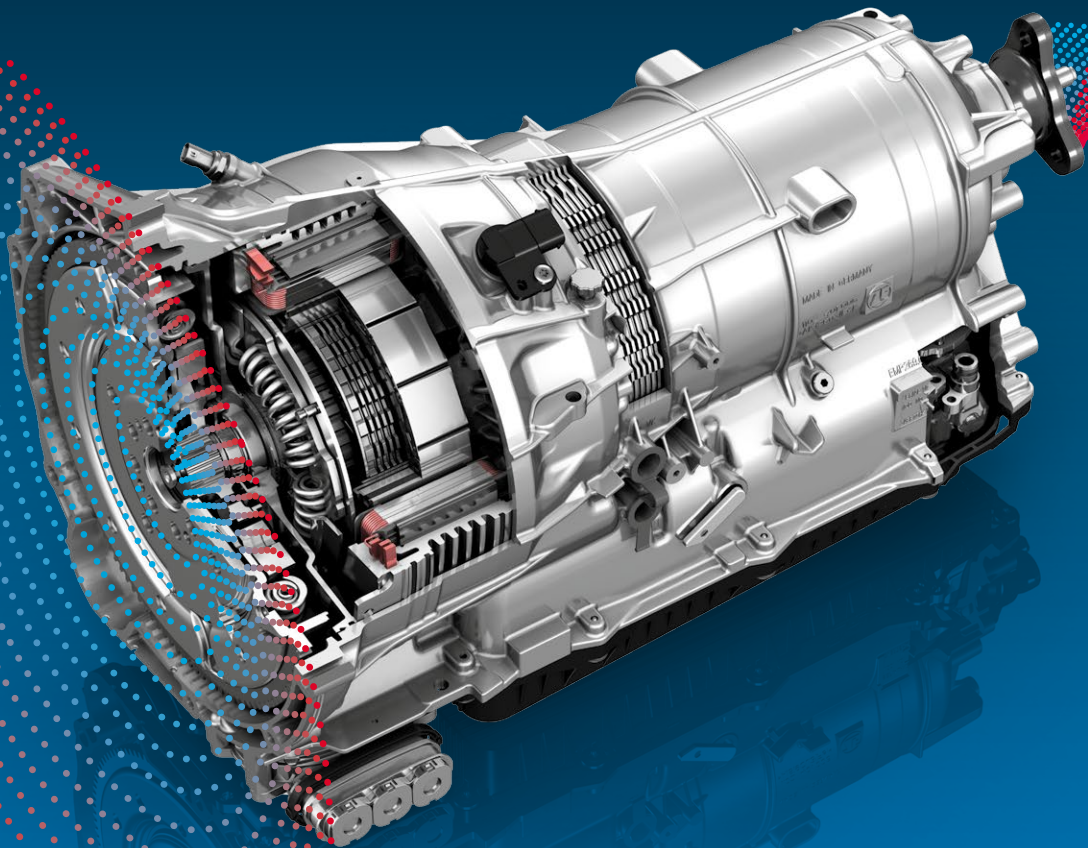

**Innovative and
fit for the future**

Millions of people around the entire world are driving with car driveline technology from ZF – today and in the future. The products are designed for efficiency and are simultaneously setting standards when it comes to comfort and driving dynamics. Vehicles equipped with ZF technology successfully walk the challenging line between the need to shape individual mobility while also doing everything possible to preserve the environment and resources. It is impossible to imagine automobiles of the future without ZF driveline technology because, with its modern and reliable components, ZF is also paving the way for many trends, such as electrification of the driveline. This culture of innovation as well as the ability to produce components of the highest quality has made ZF a valuable partner in the international automotive industry.

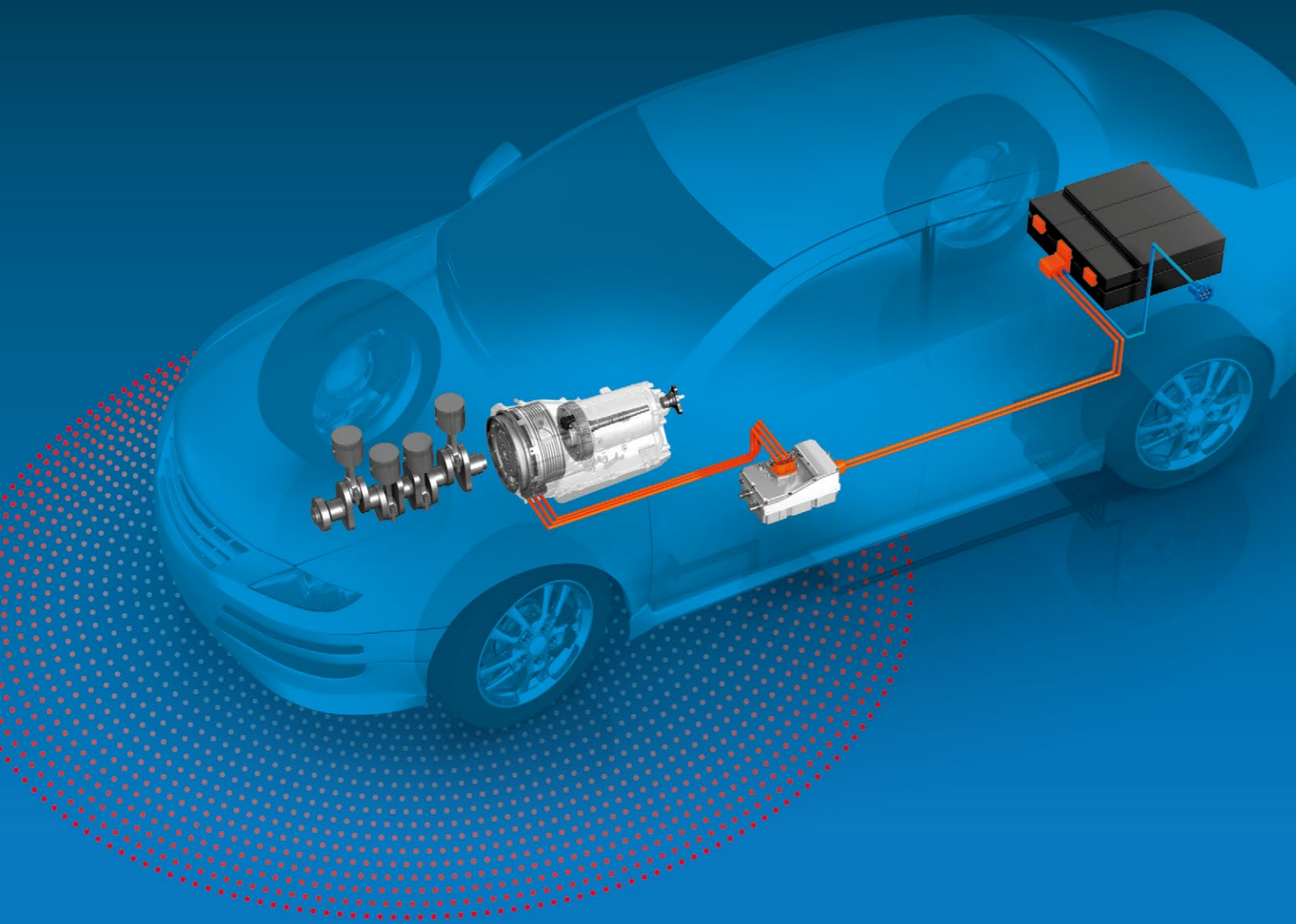

The basic transmission can be combined with multiple power take-up elements including the torque converter, the hybrid drive, and the integrated power take-up element.

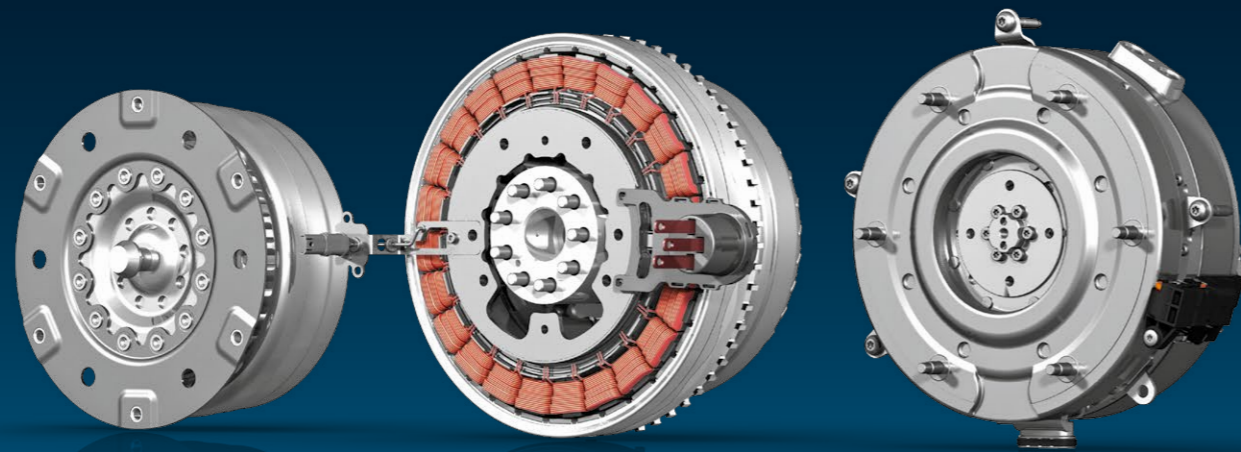

Custom – Even electrified

From individual components to the complete system: With the modular 8HP 8-speed automatic transmission kit, vehicle manufacturers find the right solution for their needs, even for electromobility applications.

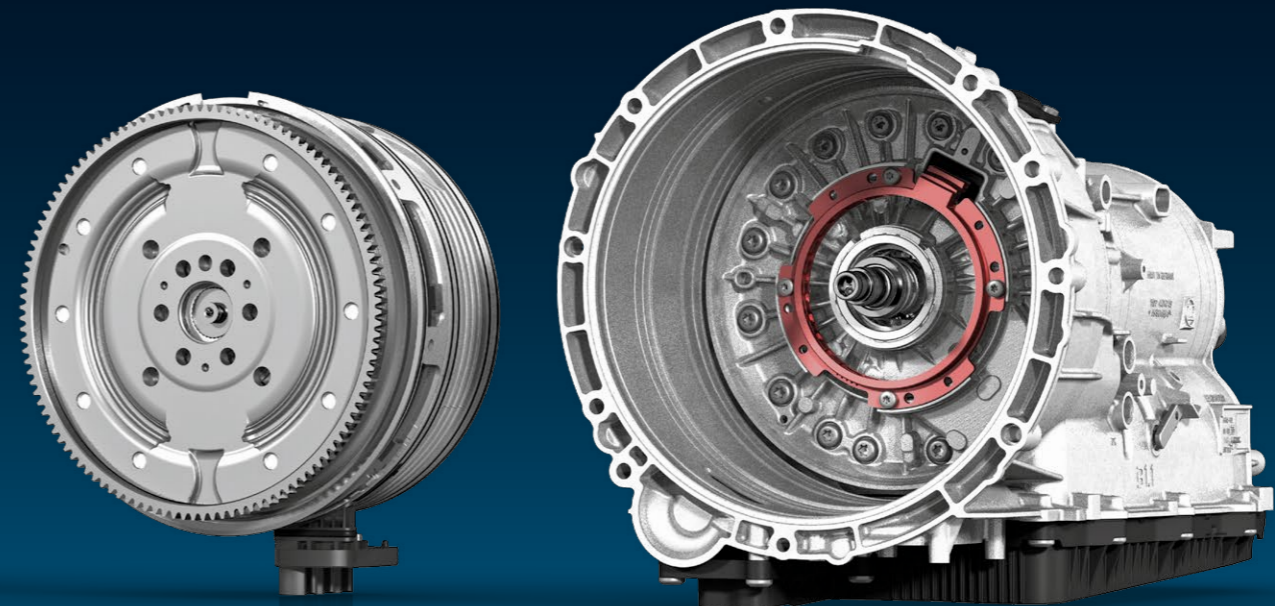

Innovative, economical and convenient: ZF's 8HP has been setting standards for automatic transmissions for years. Automotive manufacturers benefit not only from the dynamism and efficiency but also from the modular principle of the transmission, which makes it the ideal solution for all rear and all-wheel drive concepts in longitudinal design. A variable torque spectrum of 220 to 1,000 newton meters serves all desired vehicle segments, from the compact class to sporty luxury vehicles through to SUVs and delivery vans. Thanks to the modular approach, a wide range of custom applications can be achieved – with the transmission installation space remaining the same.

ZF also pursues the same principle when it comes to electromobility. Whether mild, full or plug-in hybrid: The 8HP kit covers the entire range of hybrid vehicles. Thanks to the high percentage of identical parts and the parallel hybrid design, electrification of a model platform is also very economical.

The centerpiece here is the electric motor. Depending on the hybrid application, ZF offers electric motors in different performance classes up to a maximum output of 100 kilowatts. This broad portfolio is particularly attractive for car manufacturers who are looking for individual components for their custom solutions. For example, ZF produces a hybrid module in which the electric motor is combined with a decoupling clutch in the smallest possible installation space. A newly developed converter hybrid that allows purely electric launch and energy recuperation up to shortly before vehicle standstill combines powerful electric thrust and convenient hydrodynamic power transmission. If desired, ZF can also supply a complete system – and, in addition to the hardware and software as well as the control and power electronics, provides all the necessary technologies from a single source.

Precision for more dynamics, convenience and efficiency

ZF's 8-speed automatic transmission 8HP illustrates how the power of innovation can create classics. Since 2009, it has been the benchmark in terms of flexibility, reliability and cost-effectiveness.

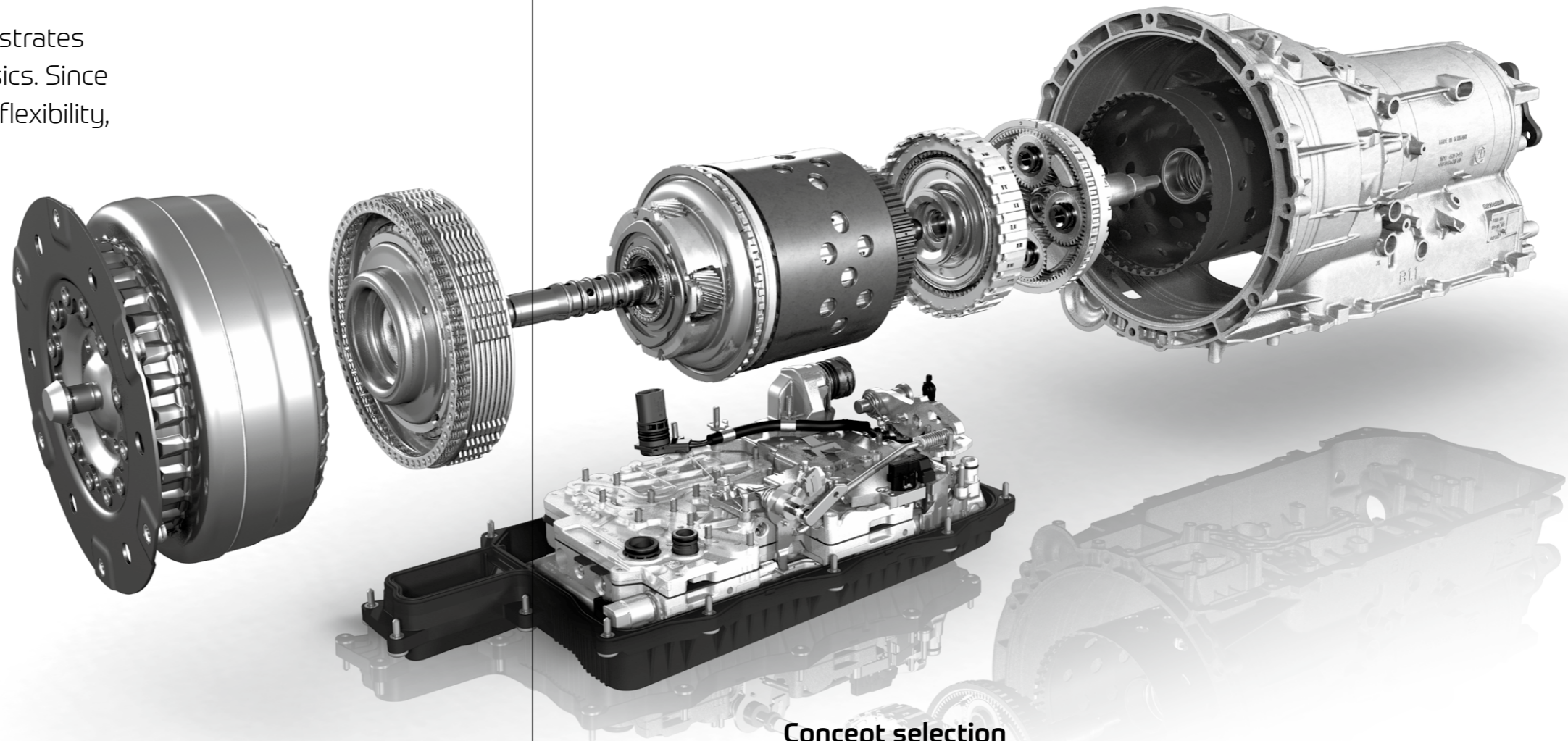

Less fuel consumption, more convenience and performance – to achieve these goals with its successful transmission, ZF developed a completely new concept in the current version. With four wheel sets, the 8HP has only five shift elements. In combination with three multidisk clutches and two brakes, it achieves higher efficiency than comparable transmissions. Since only two shift elements are opened per gear, drag losses are significantly minimized. This effect is supported by the use of a new parallel-axis vane cell pump. By integrating an electric oil pump, the 8HP now has an extended start-stop and coasting function. A low weight of 87 kilograms on average and a reduction in the engine speed increase the fuel savings potential and make the 8HP ready for future, stricter CO₂ directives.

As a result, the dynamics of the vehicle are increased with optimized speed behavior, improved transmission ratio spread and shift point optimization. With a variable torque spectrum, all-wheel drive compatibility and a wide range of hybridization options, the 8HP is the ideal partner for almost all vehicle segments and applications.



Optimizations

- For input torques starting at 220 newton meters already
- Larger transmission ratio spread of 7.81
- Multidisk separation of brakes
- Optimized cooling: less cooling oil for low system pressures, more cooling oil for high system pressures
- Functional further development of Stand-by control [SBC]
- Main pressure reduction as required
- Gearshift point optimization



With the development of the new 8-speed automatic transmission by ZF, the focus is not on the number of speeds but rather on the minimization of fuel consumption.

Concept selection

Speed	Brake		Clutch			Ratio	Ratio/steps
	A	B	C	D	E		
1	•	•	•			5.000	1.56
2	•	•			•	3.200	1.49
3		•	•		•	2.143	1.24
4		•		•	•	1.720	1.30
5		•	•	•		1.314	1.31
6			•	•	•	1.000	1.21
7	•		•	•		0.822	1.28
8	•			•	•	0.640	
R	•	•		•		-3.456	total 7.81

Sustainable concept for the powertrains of the future

ZF is continuing further optimizations in the most important transmission characteristics based on the successful 8HP series. Result: the third generation of the 8-speed automatic transmission 8HP from ZF.

Sophisticated engineering excels by making a perfect design even better by putting a great deal of passion into each and every detail. In the next version of the 8HP, which goes into volume production in 2018, ZF has made numerous improvements and changes to its modern transmission classic. After comprehensive analysis of all components, ZF redesigned the mechatronics system, further developed the torsional dampers and once again increased the maximum transmission ratio spread. The result is noticeable, far-reaching system optimization: With the same installation space, the new 8HP offers significantly more shift dynamics and driving comfort. The average fuel consumption of luxury and mid-class vehicles was reduced by a further 2.5 percent, simultaneously reducing CO₂ emissions.

Of course, the 8HP can continue to be combined with a powerful electric motor thanks to its modular approach. The transmission thus provides automotive manufacturers with a flexible option for hybridization of their model series. This means the ZF 8HP remains the transmission of choice for almost all vehicle classes with a wide range of motorization and drive variants.

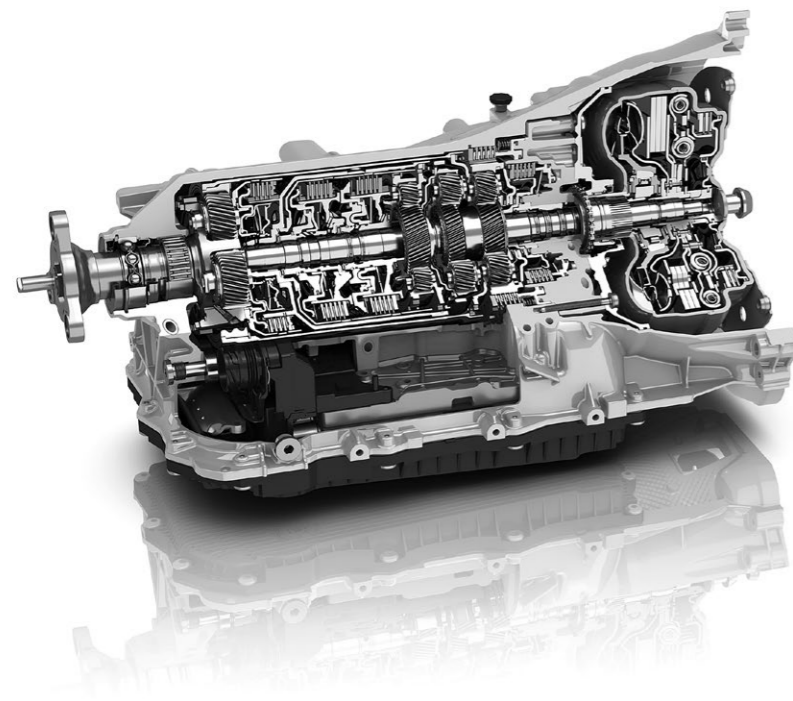

Optimizations

- Larger maximum transmission ratio spread of up to 8.6
- Drag loss optimizations (friction package and pumping losses)
- Optimized cooling oil volume and reduction of minimum main pressure
- Reduction of pumping losses
- Shifting process with regard to CO₂ and dynamics
- Further development of the torsion damper system and optimized lining-up possibilities of the torque converter lock-up clutch

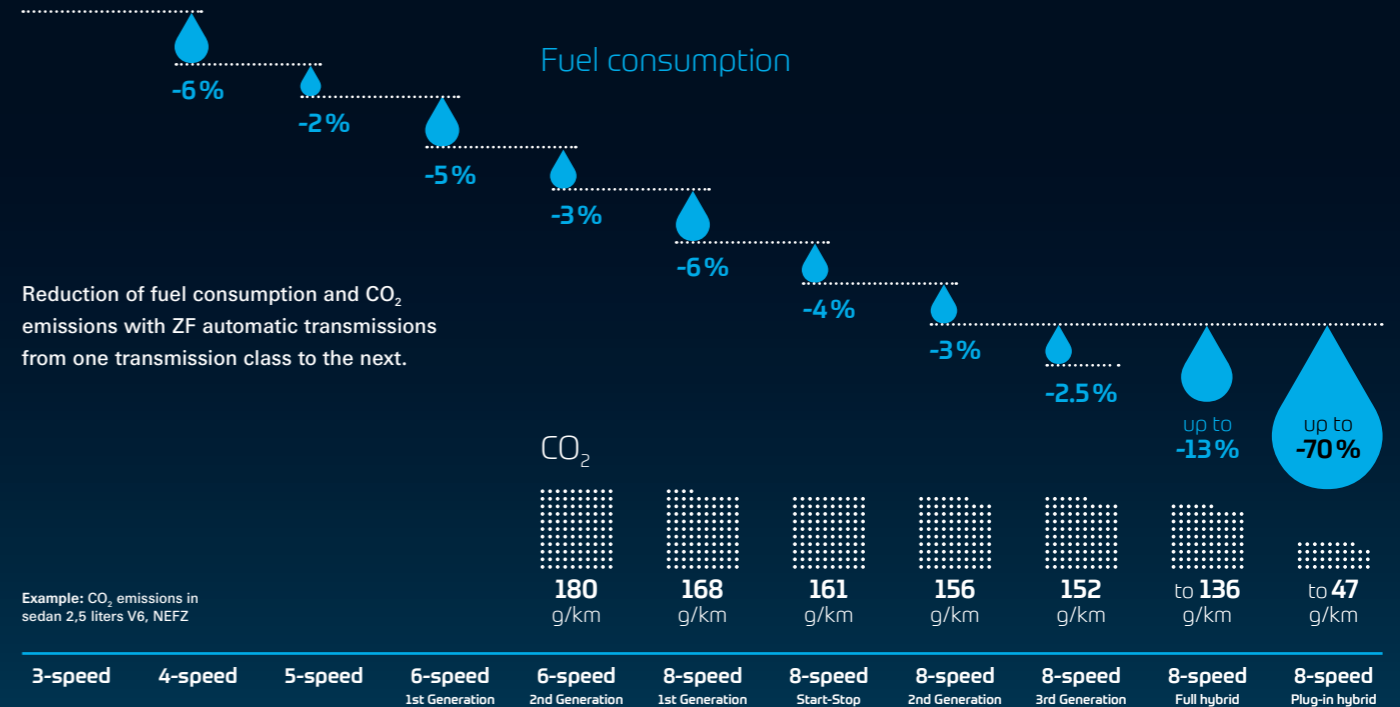

Consumption savings

The 8-speed automatic transmission reduces overall fuel consumption by at least 6% compared to present state of the art 2nd Generation ZF 6-speed automatic transmissions. As an example, the CO₂ emissions of a six-cylinder engine with a displacement of 2.5 liters can be reduced from 180 g/km to 168 g/km. An important contribution to this reduction is provided by the increasingly popular engine start/stop function, which automatically shuts off the engine when the vehicle comes to a stop and immediately re-activates the engine and transmission when the footbrake is released.

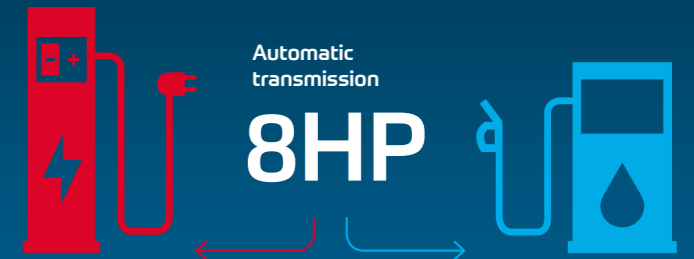

Hybrid variants

- Mildhybrid
- Full-hybrid
- Plug-in hybrid
- Torque converter hybrid

Conventional drive

- 8HP Start-Stop
- 8HP 1st Generation
- 8HP 2nd Generation
- 8HP 3rd Generation



Compatible not only with compact cars

Passenger cars with efficient ZF automatic transmissions are now in demand in all vehicle categories. Especially vehicles used in delivery traffic must cope with quick setting-off and frequent stops. The torque converter and the eight gear steps of ZF's 8-speed automatic transmission together with the high spread of gear ratios guarantee dynamic properties while at the same time keeping the engine speed and therefore also the fuel consumption at a low level. The innovative gearset concept minimizes drag losses and increases the efficiency.

The latest innovative step will be available from the middle of 2018: The 8HP of the 3rd generation with a ratio spread up to 8.6 and further improvement in CO₂ emissions, achieved through a large number of individual optimization measures.

Mild yet powerful: Mildhybrid

Mild hybrid drives are ideal for eco-friendly passenger cars, not least because the combination of electric motor and combustion engine substantially reduces the vehicle's fuel consumption. The hybrid drive impressively demonstrates that with this setup efficiency does add up to agility thanks to the boost function.

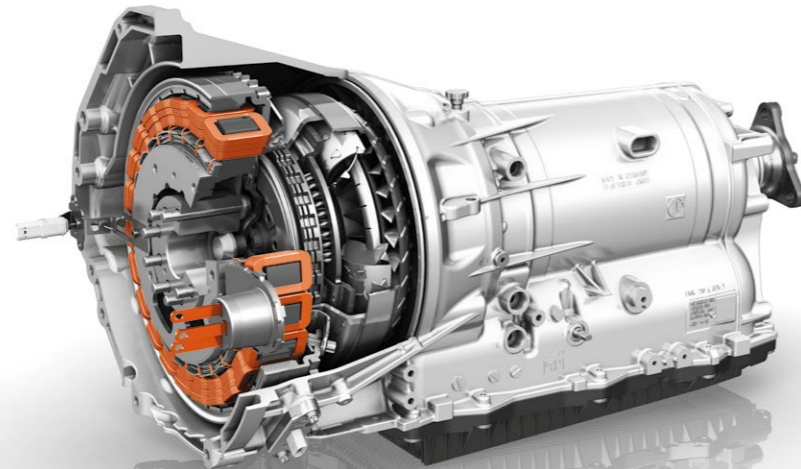

15 kW

Electric power

Economy and sporty dynamism are not necessarily mutually exclusive: After all, any fuel-efficient vehicle is transformed into a nimble athlete as soon as the electric motor in the mild hybrid version of ZF's 8-speed automatic transmission lends the combustion engine a helping hand while moving off and accelerating. The responsible electric motor is housed between the combustion engine and transmission and produces up to 15 kilowatts with over 200 newton meters of torque. Added efficiency comes courtesy of the start-stop function, which switches off the engine when the vehicle comes to a stop, and smoothly and comfortably restarts the engine as soon as the driver presses the accelerator again. Assisted by the electric motor, the combustion engine also operates within its optimum efficiency range while on the move, which has a positive impact on fuel consumption and CO₂ emissions. When the vehicle brakes, the electric motor acts as a generator and automatically charges the electric motor's battery (recuperation).



Benefits

- Boost mode
- Recuperation
- Start-stop function
- All-wheel drive compatible
- Apart from high-voltage solutions also suitable for 48 V on-board supply systems
- Electric motor with a maximum output of 15 kilowatts and maximum torque of over 200 newton meters
- Substantial reduction in fuel consumption

All-round talent: Full-hybrid

Efficient over long distances, powerful when accelerating, and all-electric capability on short journeys: the full-hybrid version of the 8-speed automatic transmission covers the full range of hybrid functions and boasts all the advantages of a standard transmission.

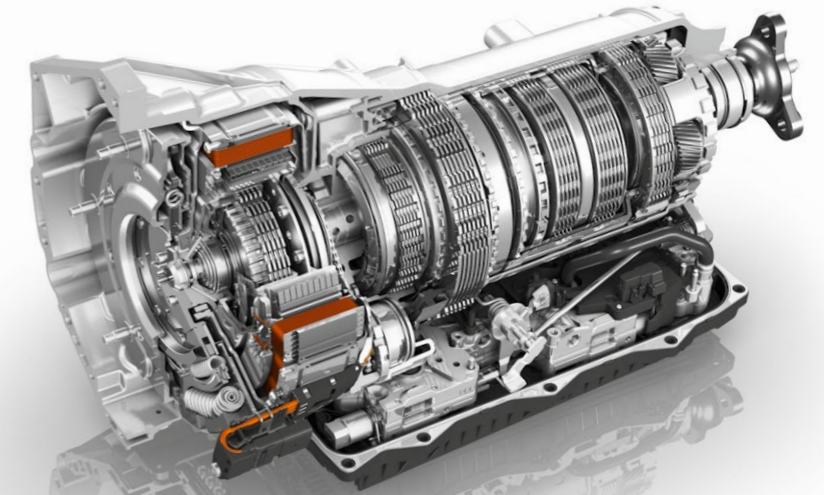

40 kW

Electric power

The combustion engine and the electric motor work together effectively on the full-hybrid variant of the 8-speed automatic transmission. A separating clutch between the two power sources enables the combustion engine to be completely decoupled from the driveline, substantially reducing fuel consumption compared with the standard transmission. Vehicles with the full-hybrid transmission provide all-electric operation at various stages – such as when moving off or over short distances. The basic transmission concept does not need to be altered either for full-hybrid operation: the electric motor, clutch, torsional dampers, and hydraulics have been fitted in the basic transmission in a space-saving and efficient manner, replacing the torque converter.



Benefits

- All functions of the standard transmission plus the advantages of the electric drive unit
- In contrast to the standard transmission, it fits into any available installation space
- Integrated electric pump (IEP)
- All-wheel drive compatible
- Electric motor with a maximum output of up to 40 kilowatts and maximum torque of up to 230 newton meters
- Electric range of up to five kilometers
- Wet integrated starting element which fits into any installation space

Fully charged: Plug-in hybrid system

The best of both worlds: Plug-in hybrids combine the range of a combustion engine with a locally emission-free electric drive.

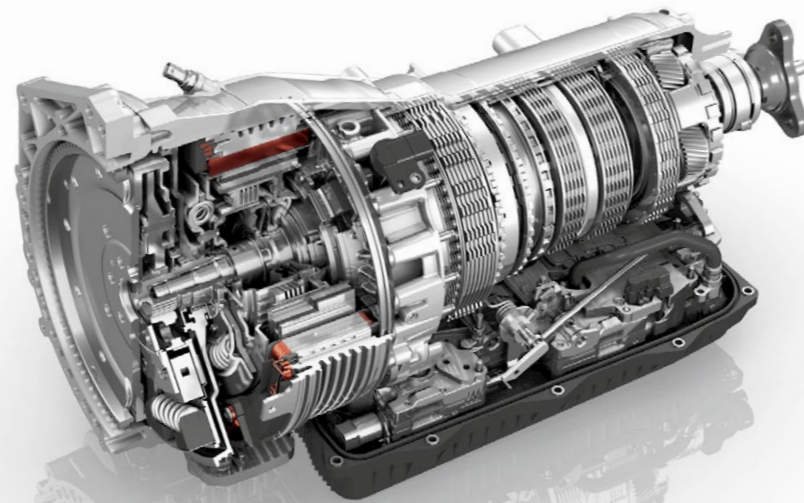

90 kW

Electric power



Benefits

- Integrated starting element fits into the available installation space
- Integrated electric pump (IEP) with an output of just 85 watts reduces the load on the on-board supply system
- Electric motor cooled either by water or transmission oil
- Separating clutch with low drag loss decouples the electric drive from the combustion engine, which, in turn, increases the range in electric mode
- Only 30 millimeters additional installation space compared with the conventional transmission
- Optimized torsional damper, even for three-cylinder engines
- Compact electric motor with a peak output of up to 90 kilowatts and 250 newton meters torque

ZF has developed a plug-in complete system for this drive configuration that sets a new benchmark in terms of all-electric range and speed compared with existing full-hybrid systems. Ranges of up to 50 kilometers and a top speed of 120 km/h (74.5 mph) in all-electric mode: ZF's highly integrated plug-in hybrid transmission enables hybrid vehicles to operate like pure electric cars. All thanks to a highly integrated complete system in which the transmission, hybrid module, and power electronics are perfectly matched to each other. At the heart of the hybrid drive is the electric motor that boasts peak output of 90 kilowatts and torque of up to 250 newton meters.

Strong performance with reduced emissions

The new ZF torque converter hybrid combines powerful electric traction and convenient hydrodynamic power transmission.

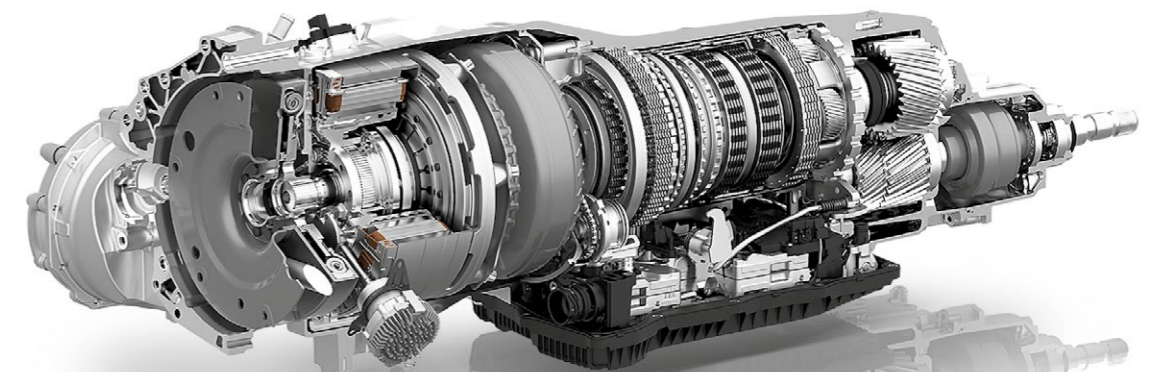

100 kW

Electric power



Benefits

- Higher recuperation potential at low speeds when starting/stopping from/to a speed of 0 rpm
- Electromechanical actuation of the K0 clutch
- Configurable torsional damper
- Compact design for easy integration into the driveline

The newly developed torque converter hybrid transmission delivers driving dynamics and convenience with the hallmark of ZF quality for a wide range of electrically driven vehicle variants. The electric motor generates just under 100 kilowatts and up to 400 newton meters. An integrated electric pump (IEP) supports the zero-emission, cost-effective driving mode. Thanks to this feature, oil pressure can be reduced to such an extent that the vehicle can start off from a standstill in electric driving mode and recuperate energy up to shortly before standstill. The compact design saves valuable installation space in the driveline. In addition, the torque converter hybrid transmission can be used for all-wheel drive vehicles and vehicles with only one driven axle.

Nine Gears – Passionate engineering

The innovative 9-speed automatic transmission 9HP pools the virtues and qualities that ZF is renowned for: high efficiency and dynamism with low fuel consumption, agility and comfort for an enhanced driving experience.

The new, innovative 9HP automatic transmission for vehicles with front-transverse mounted engines updates the classic advantages of all ZF automatic transmissions for the future: excellent efficiency and dynamics with low fuel consumption, agility combined with driving comfort, and superior driving pleasure – all created by passionate engineering. The core of the innovative concept is its modular construction system. This design makes the most of the available space and creates the best possible conditions for versatile front transverse applications. These and other advantages make the 9HP automatic transmission extremely flexible and an optimal choice for front-wheel drives and all-wheel drives with transversely installed engines with high power requirements, a segment that is particularly sensitive to installation space.

90 kg

Weight incl. oil



Benefits

- Planetary gearset with 9 speeds, 4 simple gearsets, and 6 shift elements. Gearsets are nested to save space
- Wide transmission ratio spread (nearly 10) with small ratio steps
- The first-ever use of interlocking dog clutches in a passenger car powershift transmission
- Torque converter with excellent vibration and oscillation isolation for optimal comfort during starting (driveoff) and shifting
- Proven ZF control systems technology helps provide the excellent shift quality known from the 8HP

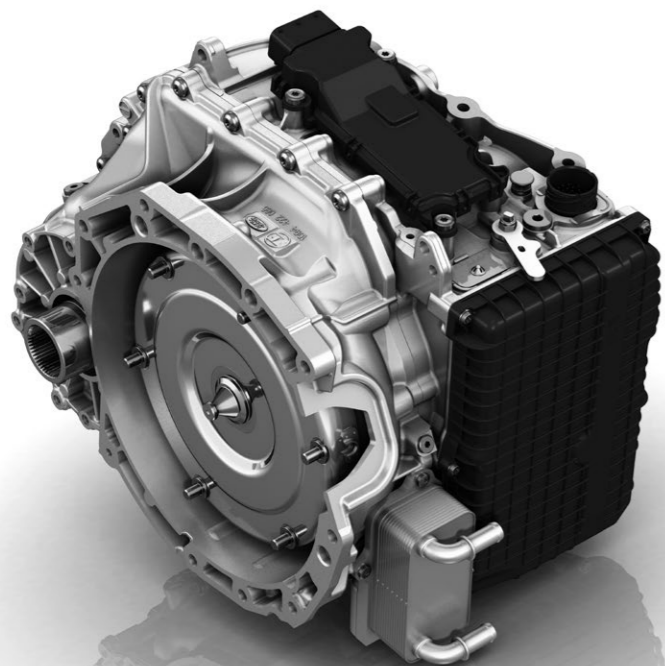

Efficiency through reduction

The new 9HP also provides increased performance with less fuel consumption: 0 to 100 km/h (62 mph) times are reduced by 2 seconds when compared with 6-speed automatic transmissions, and in real world testing at a constant speed of 120 km/h (74.5 mph), the 9HP reduced fuel consumption by 10% in a gasoline powered SUV and by 16% in a diesel-powered SUV. At the same time, the engine speeds at 120 km/h are approximately 700 rpm lower, which means less noise and greater driving comfort. These advantages are all due to the greater transmission ratio spread of the 9HP.



16%

Reduction of fuel consumption

6-speed



9-speed



Concept selection 9HP

Speed	Brake		Clutch		Dog clutch		Ratio	Ratio/steps
	C	D	B	E	F	A		
1		•			•	•	4.70	1.65
2	•				•	•	2.84	1.49
3			•		•	•	1.90	1.38
4				•	•	•	1.38	1.38
5			•	•		•	1.00	1.24
6	•			•		•	0.80	1.16
7		•		•		•	0.70	1.21
8	•	•		•			0.58	1.21
9		•	•	•			0.48	
R		•	•		•		-3.80	total 9.81

Built-in efficiency – The future is modular

Revolutionary transmission concept

ZF realized the high number of speeds in the 9HP with the help of four individual gearsets and six shifting elements. Accommodating the components in the transmission proved a major challenge – design constraints associated with the vehicle’s width severely limit the transmission installation space in front-transverse passenger cars. For this reason, the gearsets have not been arranged one behind the other on the 9HP’s longitudinal axis but were intelligently nested in. ZF has supplemented this concept by using hydraulically operated constant mesh elements, since these can be integrated without major impact on the transmission length and feature a high level of efficiency. While multidisk shift elements create drag torque when open, these losses are very low in dog clutches. This aspect is particularly important with regard to the multi-speed concept of the 9HP: thus, enhanced efficiency is not lost again via drag losses due to the more complex design.

Hydraulically operated constant mesh elements are not only highly efficient, but also contribute to the 9HP’s space-saving design.



Consistent improvement

- Ready for torque up to 500 newton meters
- Further fuel savings and CO₂ reductions
- Ready for future required MHEV/PHEV functions
- Improved shifting quality dynamic functions
- New TCU with improved processor calculation speed and capacity
- Electrical displacement sensor



Modular kit

Thanks to its modular principle, the basic transmission can be upgraded as needed. This means that different starting elements and four-wheel drive applications can be installed cost-efficiently even in the tight installation space of front-transverse passenger cars. ZF has also added to its portfolio the ECONnect drive system that can be decoupled and is customized to the demands of four-wheel drive vehicles with front-transverse engines. Thanks to its demand driven activation of the four-wheel drive, the drag losses have been considerably reduced – which has resulted in fuel and emission savings of up to 5%. Moreover, the standard 9HP is start-stop capable.

The next generation

For the next generation, ZF has improved the 9HP in all areas. A new electronic transmission control unit with a faster processor forms the basis for noticeable improvement in dynamics with a simultaneous reduction in CO₂ emissions. Thanks to an optimized cooling oil circuit and shift sequence as well as a reduction in the minimum primary pressure, the 9HP now consumes 2 percent less fuel (when installed in luxury and midsize vehicles) compared to its predecessor.

At the same time, the torque capacity was increased to 500 newton meters and newly developed displacement sensors for the shift claws were installed. This increases shift comfort and driving dynamics despite a reduction in fuel consumption. In addition, a mechanical system with optimized details and a transmission main pump powered by an electric motor pave the way for mild or plug-in hybrid functions.

Space-saving interleaving of the gear sets makes it possible to use the 9HP even when the installation space is limited. In combination with the efficient modular system, vehicle manufacturers can cost-effectively use different launch elements and implement all-wheel drive applications. This makes the 9HP the perfect partner for the world’s most common drive configuration.

ZF sees electronics and software as key factors in meeting vehicle efficiency targets and reducing CO₂ emissions. The electronic control unit significantly helps to reduce fuel consumption by up to 16 percent with the 9HP.

16%

Consumption savings

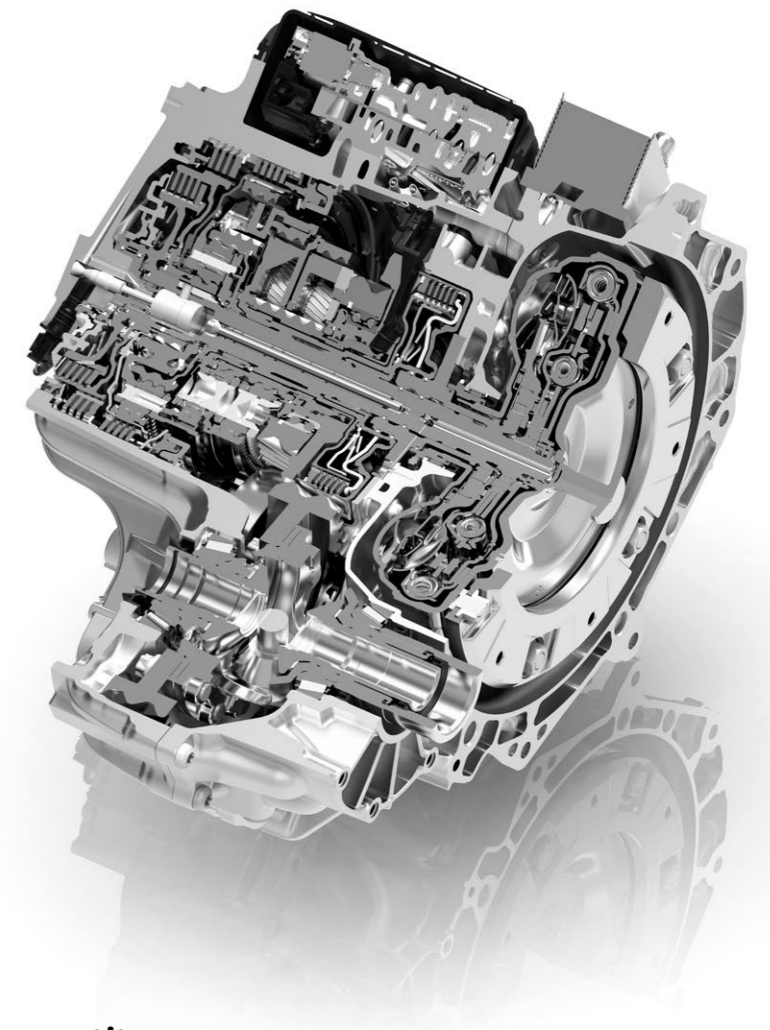

Power to weight ratios 9HP vs. competitors

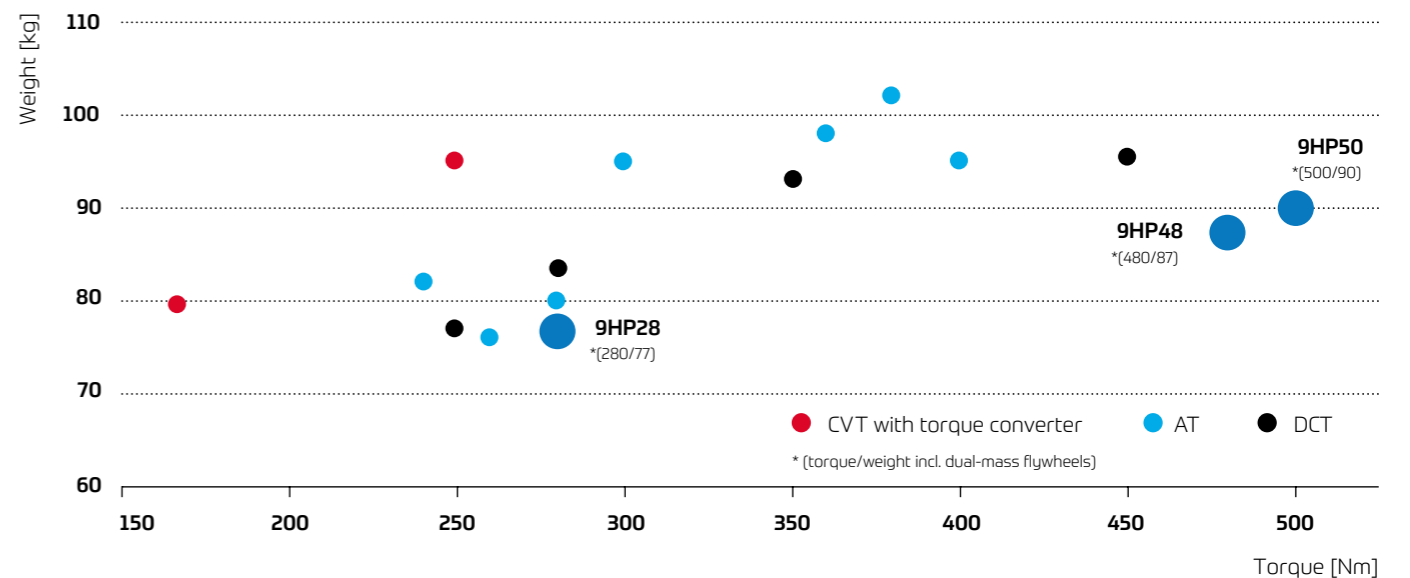

Research and development to secure mobility

Innovations are not an end in themselves, they must pay off: For manufacturers, fleet owners, and drivers, but also for the environment and society. Each new development must prove itself among the conflicting priorities of these criteria.

The ZF Group draws upon an international network of development centers. Each year, ZF invests approximately five percent of its sales in R&D. With success, because innovative products from ZF set the standards for state-of-the-art technology – again and again.

Development work at ZF is organized according to decentralized and corporate functions. The divisions and business units focus on markets and product expertise, ensuring customer-centered, competitive technological product development. Corporate R&D works with a strong emphasis on basic research and theory, and supports the operational development departments in the divisions.

Groundbreaking innovations

Over the past years, this partnership has produced product innovations that have since become benchmarks in the industry: Just some examples are the 8-speed automatic transmission for cars as well as hybrid transmissions and hybrid management for cars and commer-

cial vehicles, or the modular TraXon transmission system for commercial vehicles. Groundbreaking innovations from ZF are in use today not just in passenger cars and commercial vehicles on the road, but also in all kinds of craft on the water and in the air.

What's more, the innovative power of ZF is set to increase in the future. Proof of this is already provided by the number of patents pending: A look at the statistics of the German Patent and Trademark Register shows that ZF is among the top ten applicants for patents – at eye level with many large automotive manufacturers. Each year, the research departments successfully complete more than 10,000 projects, covering the full range from basic research to product applications. This high project volume is necessary to ensure mobility in the future. The trend toward hybrid solutions already shows that green drive technology is very complex. The same goes for pure electric drives and lightweight design engineering. Currently, ZF engineers are conducting pioneering work on alternative materials, broader approaches in design and testing, and new production processes.



ZF Friedrichshafen AG

PO Box 65 04 64
66143 Saarbrücken
Germany

Phone +49 681 920-0
Fax +49 681 920-2377
www.zf.com



twitter.com/zf_group
facebook.com/zffriedrichshafen
youtube.com/zffriedrichshafenag